



**MAINE DEPARTMENT OF
INLAND FISHERIES AND WILDLIFE**

ADDENDUM NO. 5

01-SEP-23

TO THE SPECIFICATIONS, PROPOSAL, CONTRACT AND BOND
FOR THE CONSTRUCTION OF

**IMPROVEMENTS AT GRAND LAKE STREAM STATE FISH HATCHERY
GRAND LAKE STREAM, MAINE**

WASHINGTON COUNTY

BGS PROJECT NO.: 3289-14

BID DATE: 07 SEPTEMBER 2023



| | |
|-----------------|-------------------------------------------------------|
| SUBJECT: | ADDENDUM NO. 5 |
| PROJECT: | Improvements at Grand Lake Stream State Fish Hatchery |
| DATE: | Friday, September 01, 2023 |
| TO: | Richard Parker - DIFW |
| FROM: | Andrew Gurski – HDR |

This Addendum is issued to known individuals, firms or corporations holding Bidding Documents and Contract Documents for above listed project.

This Addendum is hereby made a portion of Bidding Documents and Contract Documents.

QUESTIONS AND ANSWERS

1. **QUESTION:** Does the new clarifier need to be put on line before the existing clarifier is demolished?
ANSWER: DIFW understands there will be a period of time when there will be no clarifier to settle fish wastes while the hatchery remains in operation. This will require alternative raceway cleaning methods (ie. vacuuming wastes onto a truck) by DIFW staff once the clarifier goes offline. DIFW asks that the contractor limit this period of time to the extent possible while conducting necessary construction activities and communicate timing of needed closure well in advance.
SOURCE: Mark McPheters <mark@tbuckconstruction.net> Tue 8/29/2023 09:44

2. **QUESTION:** Does the entire foundation, walls and floor, of the existing clarifier need to be removed? That excavation was wet and deep and will be expensive to completely remove. I don't believe the effluent building is nearly as deep as the clarifier.
ANSWER: Contractor shall completely removal all items associated with the existing clarifier.
SOURCE: Mark McPheters <mark@tbuckconstruction.net> Monday, August 28, 2023 4:17 PM

3. **QUESTION:** Pipe type 'DRN' is not listed in pipe schedule
ANSWER: DRN function is PVC, schedule 40, ASTM D1785 with normal impact, socket solvent welded joints.
SOURCE: Mark McPheters <mark@tbuckconstruction.net> Wed 8/30/2023 13:52

SPECIFICATION UPDATES

4. **SECTION 00 22 13 INSTRUCTIONS TO FILED SUB-BIDDERS**
REMOVED: Removed Section from Construction Manual

5. **SECTION 31 23 33 – TRENCHING, BACKFILLING AND COMPACTING FOR UTILITIES**
 - a. **Part 2.1, A., 1.:** Delete “and not within 16’ of pond rims.”
 - b. **Part 2.1, A.:** Delete all of 2.
 - c. **Part 2.1, A., 3.:** Delete “within 16-feet of a pond water surface.”



- d. **Part 2.1, C.: Replace 1, 2 and 3 With** “Class II Poorly Graded Sand (SP) or Well Graded Sand (SW) per ASTM D2321, compacted to no less than 85% Standard Proctor Density.”
- 6. SECTION 40 05 52 – MISCELLANEOUS VAVLES**
 - a. PART 2.5, ADD: B. “Mud valves shall be provided with 4 foot stem extension supported by a 1 foot wall mounted bracket to the nearest wall”.
- 7. SECTION 40 60 05 – SLUICE & SLIDE GATES AND METAL STOP LOGS**
 - a. PART 1.1, REMOVE: PART A.
 - b. PART 1.1, B, REMOVE: PART 3.
 - c. REMOVE PARTS 2.2, 2.3, 2.4, 2.5, and 2.6 because they are described in section 40 05 52.

DRAWING UPDATES

- 8. SHEET 00S-601: STRUCTURAL SCHEDULES**
UPDATE: DELETE WHOLE SHEET
- 9. SHEET 00D-602: PROCESS SCHEDULES 1**
UPDATE: DRUMFILTER SCHEDULE, BYPASS WEIR LENGTH PER SIDE: Change “3 FT” to “4.5 ft.”
- 10. SHEET 02S-102: UPPER PAVILION FRAMING PLAN**
UPDATE: Sheet was updated to add additional details for storage room ceiling. See attached drawing.
- 11. SHEET 03S-102: LOWER PAVILION FRAMING PLAN**
UPDATE: Sheet was updated to add additional details for storage room ceiling. See attached drawing.
- 12. SHEET 02D-401: UPPER PAVILION ENLARGED PLAN & DETAILS**
 - a. **UPDATE:** REPLACE “2-½ INCH ALUMINUM WEIR BOARD GUIDES W/ EPOXY RESIN INSULATING THE ALUMINUM FROM THE CONC. MANHOLE” WITH “PROVIDE METAL STOP LOG SYSTEM, 9 FEET TALL WITH EIGHTEEN SIX-INCH LOGS NOMINALLY 4 FEET LONG AND GUIDES ADAPTED TO CURVED WALLS”
 - b. **UPDATE:** REPLACE “2 FT –0 IN” WITH “3 FT –0 IN”
- 13. SHEET 01D-101: OVERALL SITE PIPING PLAN, KEYNOTE 2**
REPLACE: “PROVIDE ¾" VALVE & CAP FOR FUTURE USE.” WITH “PROVIDE ¾" INSULATION VALVE WITH OXYGEN METER AS SCHEDULED ON SHEET 00D-603”
- 14. SHEET 05D-101: EXISTING RACEWAY LHO PIPING PLAN AND SECTIONS**
 - a. **UPDATE:** SECTION 6, REPLACE: “TYPICAL STOPLOGS PER STRUCTURAL SHEETS” with “FOUR 2 INCH X 6 INCH X 63 INCH X ¼ INCH ALUMINUM C-CHANNELS AND ONE 2 INCH X 3 INCH X 63 INCH ALUMINUM C-CHANNEL”. (These are NOT metal stop log systems as described in Specification Section 40 60 05.)
 - b. **UPDATE:** SECTION 5, REPLACE: “TYPICAL STOPLOGS PER STRUCTURAL SHEETS” with “FOUR 2 INCH X 6 INCH X 63 INCH x ¼ inch ALUMINUM C-CHANNELS AND ONE 2 INCH X



- 3 INCH X 63 INCH ALUMINUM C-CHANNEL". (These are NOT metal stop log systems as described in Specification Section 40 60 05.)
- c. **UPDATE:** SECTION 4, REPLACE: "TYPICAL STOPLOGS PER STRUCTURAL SHEETS WITH FIVE 2 INCH X 6 INCH X 63 INCH x ¼ inch ALUMINUM C-CHANNELS". (These are NOT metal stop log systems as described in Specification Section 40 60 05.)
- d. **ADD:** TYPICAL ¾" ISOLATION VALVE ON ¾" OXYGEN LINE, UPSTREAM OF OXYGEN METERS.
- e. **ADD:** Typical 2' dimension between floor and oxygen flow meters. See image below and attached drawing.

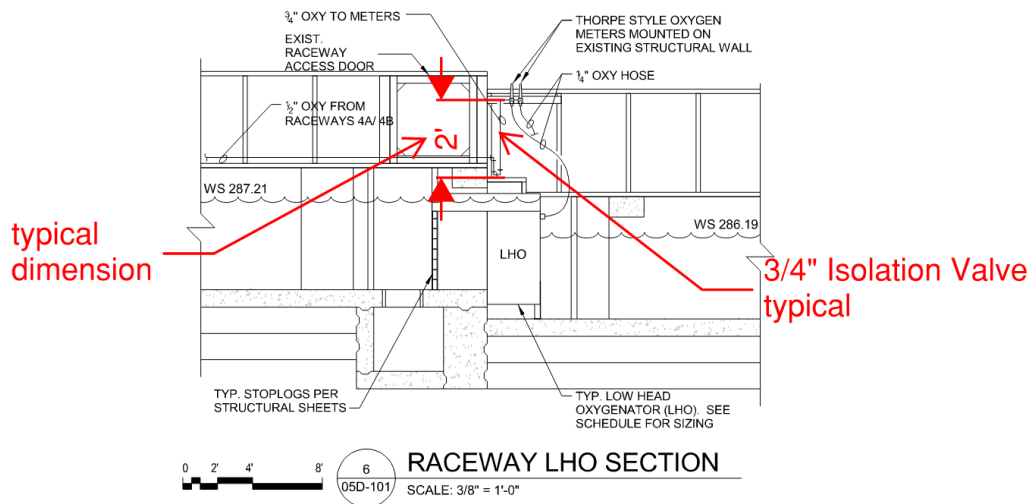

15. SHEET 04D-404: SLUDGE STORAGE PROCESS PIPING PLAN & DETAILS, SECTION 2

REPLACE: "24-IN ID MINIMUM HINGED & LOCK HASPED HATCH FOR CLEAR ACCESS INTO TANK" WITH "30-IN X 30-IN MINIMUM HINGED & LOCK HASPED HATCH FOR CLEAR ACCESS INTO TANK" See attached drawing.

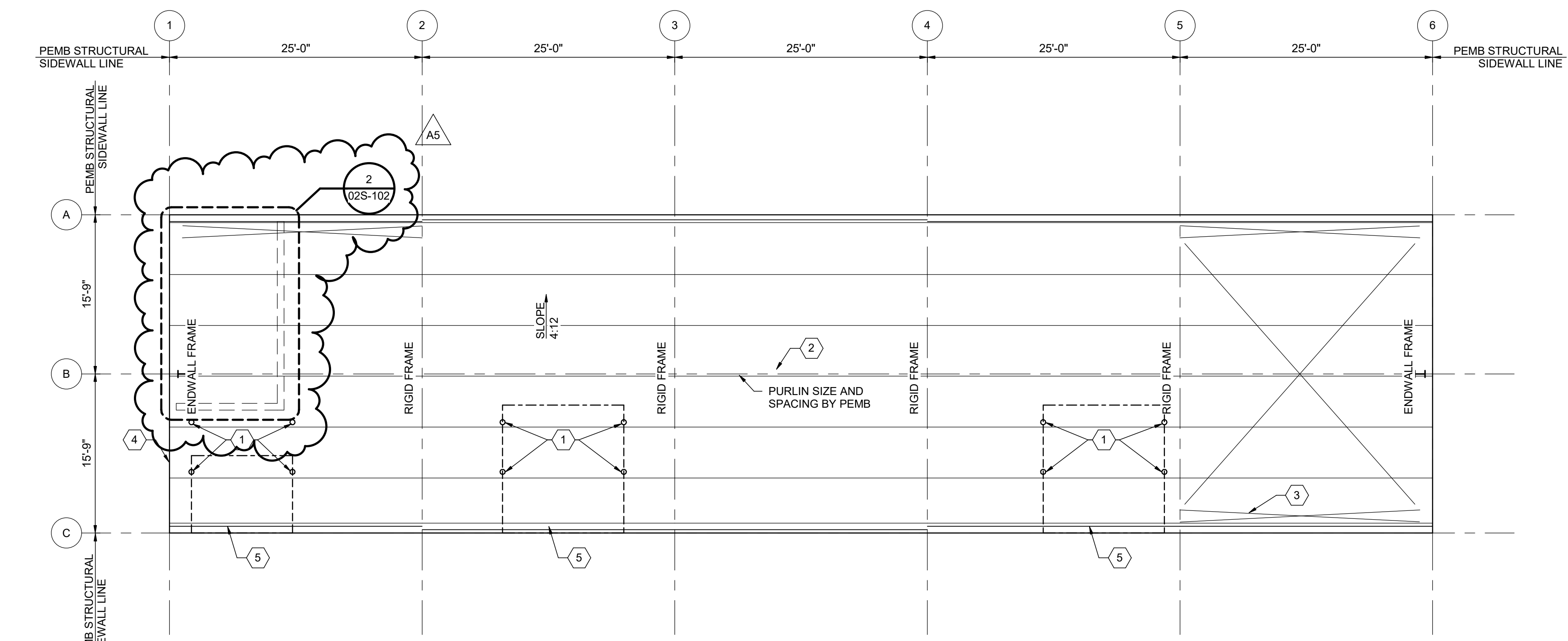

ROOF FRAMING PLAN
1/8" = 1'-0"

- GENERAL NOTES:**
- SEE SHEET 00S-001 FOR DESIGN STANDARDS AND BUILDING CODE INFORMATION.
 - SEE SHEET 00S-001 FOR DESIGN LOADS.
 - PIER CONFIGURATIONS ARE AS INDICATED ON SHEET 02S-302. IF THESE CONFIGURATIONS ARE NOT COMPATIBLE TO THE PEMB DESIGN THE GENERAL CONTRACTOR SHALL NOTIFY THE ENGINEER IN WRITING SUCH THAT MODIFICATIONS CAN BE MADE PRIOR TO PIER REINFORCEMENT FABRICATION AND CONSTRUCTION.
 - GENERAL ASSUMPTIONS HAVE BEEN MADE BY THE STRUCTURAL ENGINEER FOR THE FOUNDATION DESIGN. THE GENERAL CONTRACTOR AND PEMB SHALL SUBMIT FRAME REACTIONS TO THE ENGINEER FOR VERIFICATION WITH THE FOUNDATIONS SHOWN. ADJUSTMENTS MAY BE REQUIRED IN THE FIELD PRIOR TO CONSTRUCTION. ANY CHANGES REQUIRED SHALL BE MADE AT NO ADDITIONAL COST TO THE PROJECT.
 - FRAME REACTIONS AND ANCHOR BOLT SETTING PLAN SHALL BE SUBMITTED TO THE ENGINEER CONCURRENTLY WITH THE CONCRETE REINFORCEMENT SHOP DRAWINGS FOR REVIEW AND APPROVAL. ANY CHANGES REQUIRED SHALL BE MADE AT NO ADDITIONAL COST TO THE PROJECT.
 - THE PEMB SHALL DESIGN ALL ANCHOR BOLTS. ANCHOR BOLT SIZES SHALL BE FURNISHED TO THE GENERAL CONTRACTOR. THE GENERAL CONTRACTOR SHALL FURNISH AND INSTALL ALL ANCHOR BOLTS.
 - ALL RIGID FRAMES SHALL HAVE PINNED CONNECTIONS TO THE FOUNDATION.
 - COLUMN BASE PLATES SHALL BE LEVELED WITH LEVELING NUTS OR SHIMS AND GROUTED SOLID WITH 2" NON-SHRINK GROUT.
 - PEMB AND CONTRACTOR SHALL PROVIDE BRACING AS NECESSARY TO MAINTAIN FLAT AND LEVEL GIRTS DURING BUILDING ERECTION.

- KEYNOTES: #**
- DENOTES APPROXIMATE POINT LOAD LOCATIONS FOR OVERHEAD DOOR TRACK. GENERAL CONTRACTOR SHALL COORDINATE WEIGHT AND LOCATION WITH PRE-ENGINEERED METAL BUILDING MANUFACTURER.
 - PURLIN SIZE, SPACING AND MATERIAL PROVIDED BY PEMB.
 - ANTICIPATED LOCATION OF CROSS BRACING IN ROOF AND WALLS.
 - MANDOOR FRAMING PROVIDED AND INSTALLED BY PEMB.
 - OVERHEAD DOOR FRAMING PROVIDED AND INSTALLED BY PEMB.

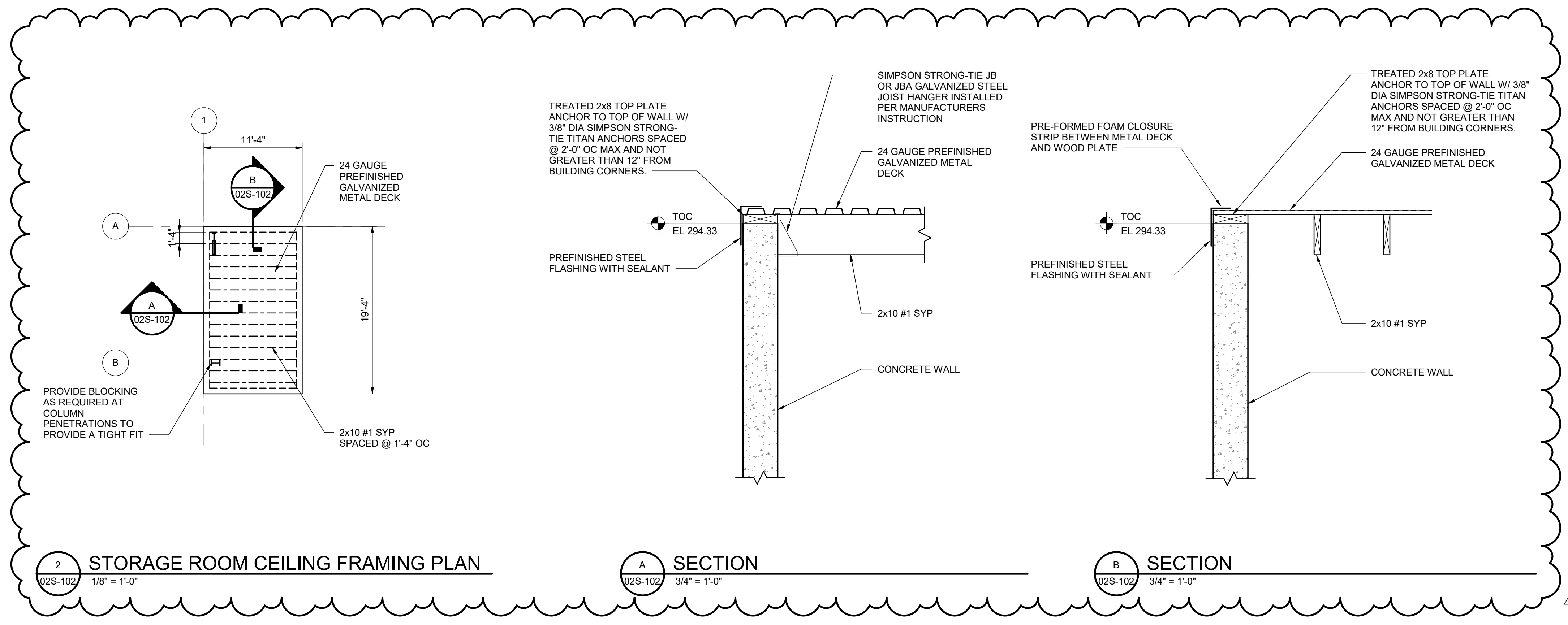

2 STORAGE ROOM CEILING FRAMING PLAN
1/8" = 1'-0"

A SECTION
3/4" = 1'-0"

B SECTION
3/4" = 1'-0"

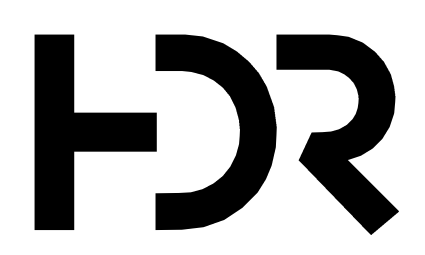

| ISSUE | DATE | DESCRIPTION |
|-------|------------|----------------|
| A5 | 08/31/2023 | ADDENDUM 5 |
| | 07/14/2023 | ISSUED FOR BID |

| | |
|------------------------|---------------|
| PROJECT MANAGER | ANDREW GURSKI |
| CIVIL | J. GAGNON |
| STRUCTURAL | B. BRADLEY |
| ARCHITECTURAL | M. BASKIN |
| PROCESS | J. CHANDLER |
| MECHANICAL | J. CHANDLER |
| ELECTRICAL | A. KANER |
| PROJECT NUMBER | 10357686 |

IMPROVEMENTS AT GRAND LAKE STREAM STATE FISH HATCHERY

UPPER PAVILION FRAMING PLAN



FILENAME | 10353741-02-S.rvt
SCALE | As indicated

SHEET
02S-102

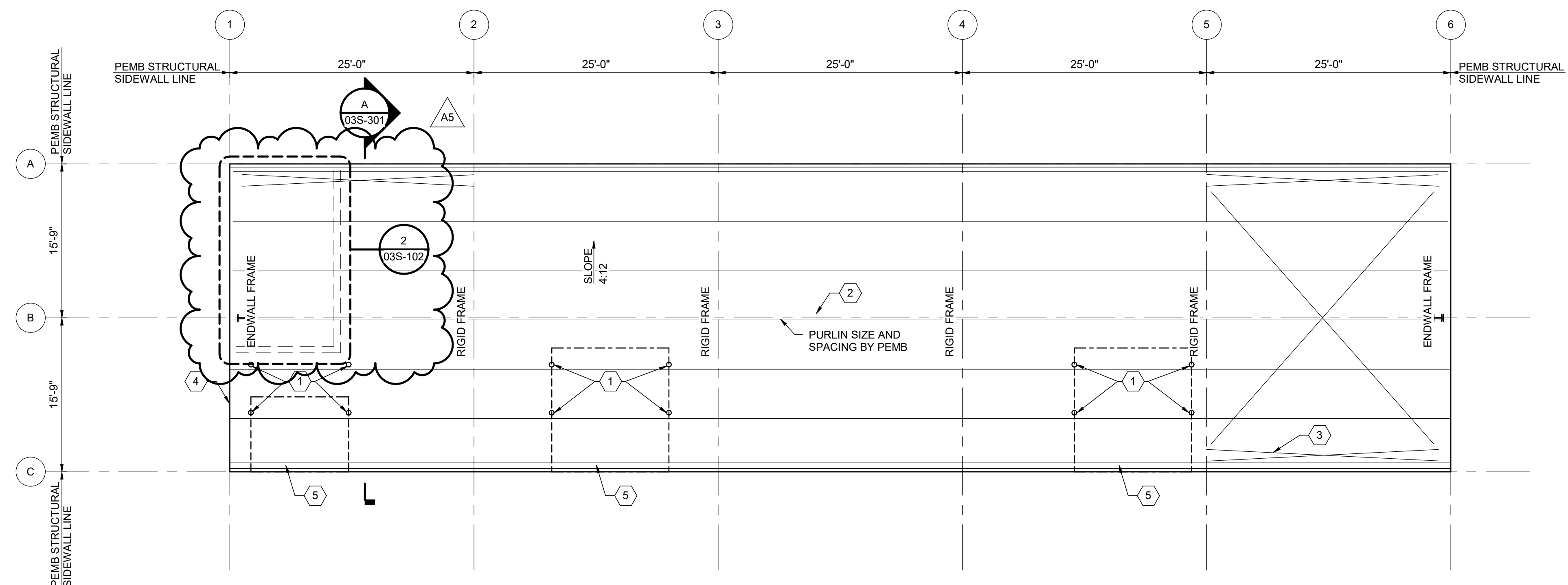
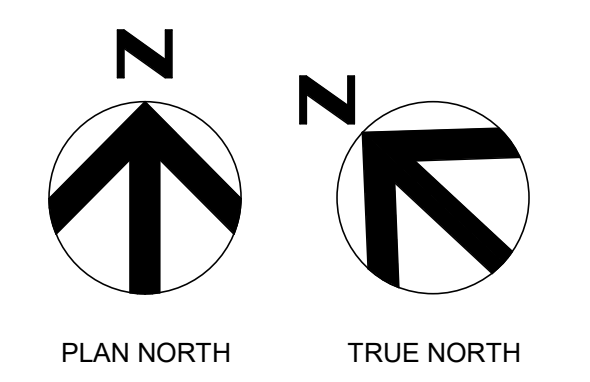

ROOF FRAMING PLAN
1/8" = 1'-0"

- GENERAL NOTES:**
- SEE SHEET 00S-001 FOR DESIGN STANDARDS AND BUILDING CODE INFORMATION.
 - SEE SHEET 00S-001 FOR DESIGN LOADS.
 - PIER CONFIGURATIONS ARE AS INDICATED ON SHEET 03S-302. IF THESE CONFIGURATIONS ARE NOT COMPATIBLE TO THE PEMB DESIGN THE GENERAL CONTRACTOR SHALL NOTIFY THE ENGINEER IN WRITING SUCH THAT MODIFICATIONS CAN BE MADE PRIOR TO PIER REINFORCEMENT FABRICATION AND CONSTRUCTION.
 - GENERAL ASSUMPTIONS HAVE BEEN MADE BY THE STRUCTURAL ENGINEER FOR THE FOUNDATION DESIGN. THE GENERAL CONTRACTOR AND PEMB SHALL SUBMIT FRAME REACTIONS TO THE ENGINEER FOR VERIFICATION WITH THE FOUNDATIONS SHOWN. ADJUSTMENTS MAY BE REQUIRED IN THE FIELD PRIOR TO CONSTRUCTION. ANY CHANGES REQUIRED SHALL BE MADE AT NO ADDITIONAL COST TO THE PROJECT.
 - FRAME REACTIONS AND ANCHOR BOLT SETTING PLAN SHALL BE SUBMITTED TO THE ENGINEER CONCURRENTLY WITH THE CONCRETE REINFORCEMENT SHOP DRAWINGS FOR REVIEW AND APPROVAL. ANY CHANGES REQUIRED SHALL BE MADE AT NO ADDITIONAL COST TO THE PROJECT.
 - THE PEMB SHALL DESIGN ALL ANCHOR BOLTS. ANCHOR BOLT SIZES SHALL BE FURNISHED TO THE GENERAL CONTRACTOR. THE GENERAL CONTRACTOR SHALL FURNISH AND INSTALL ALL ANCHOR BOLTS.
 - ALL RIGID FRAMES SHALL HAVE PINNED CONNECTIONS TO THE FOUNDATION.
 - COLUMN BASE PLATES SHALL BE LEVELED WITH LEVELING NUTS OR SHIMS AND GROUTED SOLID WITH 2" NON-SHRINK GROUT.
 - PEMB AND CONTRACTOR SHALL PROVIDE BRACING AS NECESSARY TO MAINTAIN FLAT AND LEVEL GIRTS DURING BUILDING ERECTION.

- KEYNOTES:** #
- DENOTES APPROXIMATE POINT LOAD LOCATIONS FOR OVERHEAD DOOR TRACK. GENERAL CONTRACTOR SHALL COORDINATE WEIGHT AND LOCATION WITH PRE-ENGINEERED METAL BUILDING MANUFACTURER.
 - PURLIN SIZE, SPACING AND MATERIAL PROVIDED BY PEMB.
 - ANTICIPATED LOCATION OF CROSS BRACING IN ROOF AND WALLS.
 - MANDOOR FRAMING PROVIDED AND INSTALLED BY PEMB.
 - OVERHEAD DOOR FRAMING PROVIDED AND INSTALLED BY PEMB.

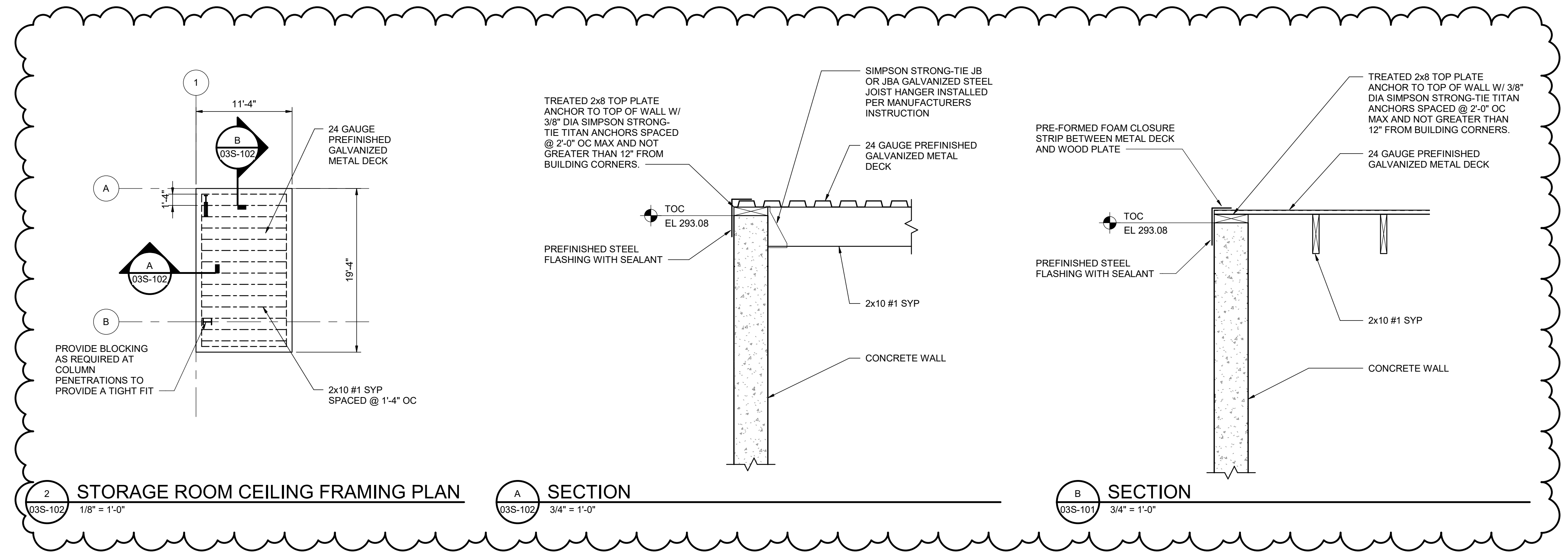

2 STORAGE ROOM CEILING FRAMING PLAN
03S-102 1/8" = 1'-0"

A SECTION
03S-102 3/4" = 1'-0"

B SECTION
03S-101 3/4" = 1'-0"

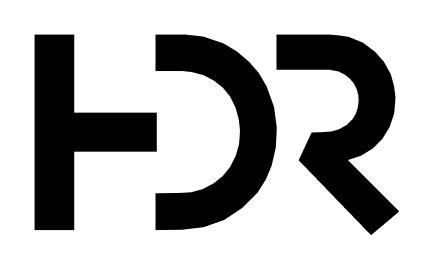

| ISSUE | DATE | DESCRIPTION |
|-------|------------|----------------|
| A5 | 08/31/2023 | ADDENDUM 5 |
| | 07/14/2023 | ISSUED FOR BID |

| | |
|--------------------------------------|-------------|
| PROJECT MANAGER ANDREW GURSKI | |
| CIVIL | J. GAGNON |
| STRUCTURAL | B. BRADLEY |
| ARCHITECTURAL | M. BASKIN |
| PROCESS | J. CHANDLER |
| MECHANICAL | J. CHANDLER |
| ELECTRICAL | A. KANER |
| PROJECT NUMBER | 10357686 |

IMPROVEMENTS AT GRAND LAKE STREAM STATE FISH HATCHERY

LOWER PAVILION FRAMING PLAN

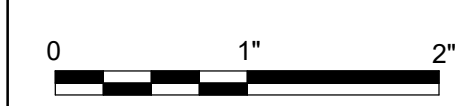

FILENAME | 10353741-03-S.rvt
SCALE | As indicated

SHEET
03S-102

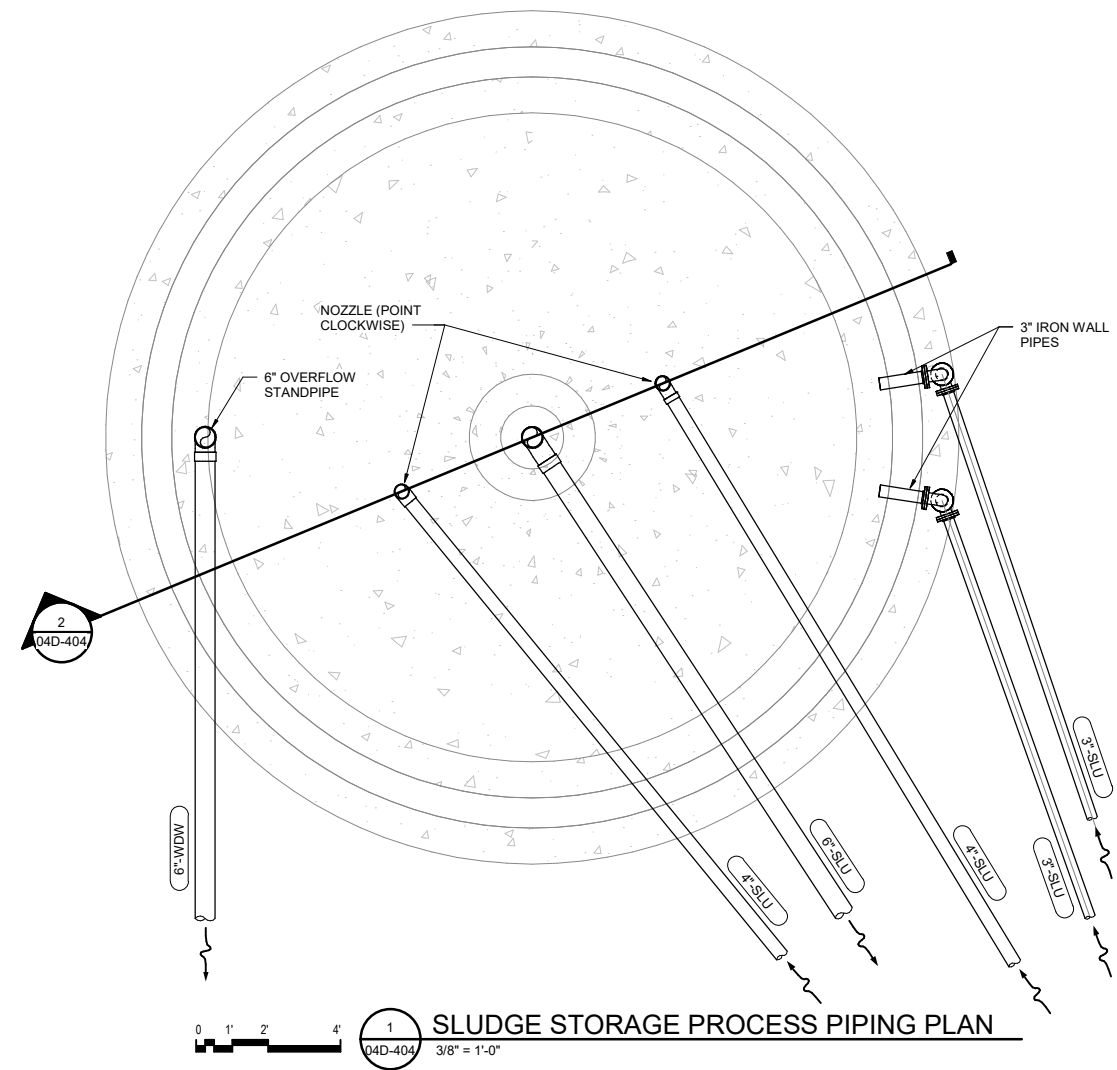

1 SLUDGE STORAGE PROCESS PIPING PLAN
04D-404 3/8" = 1'-0"

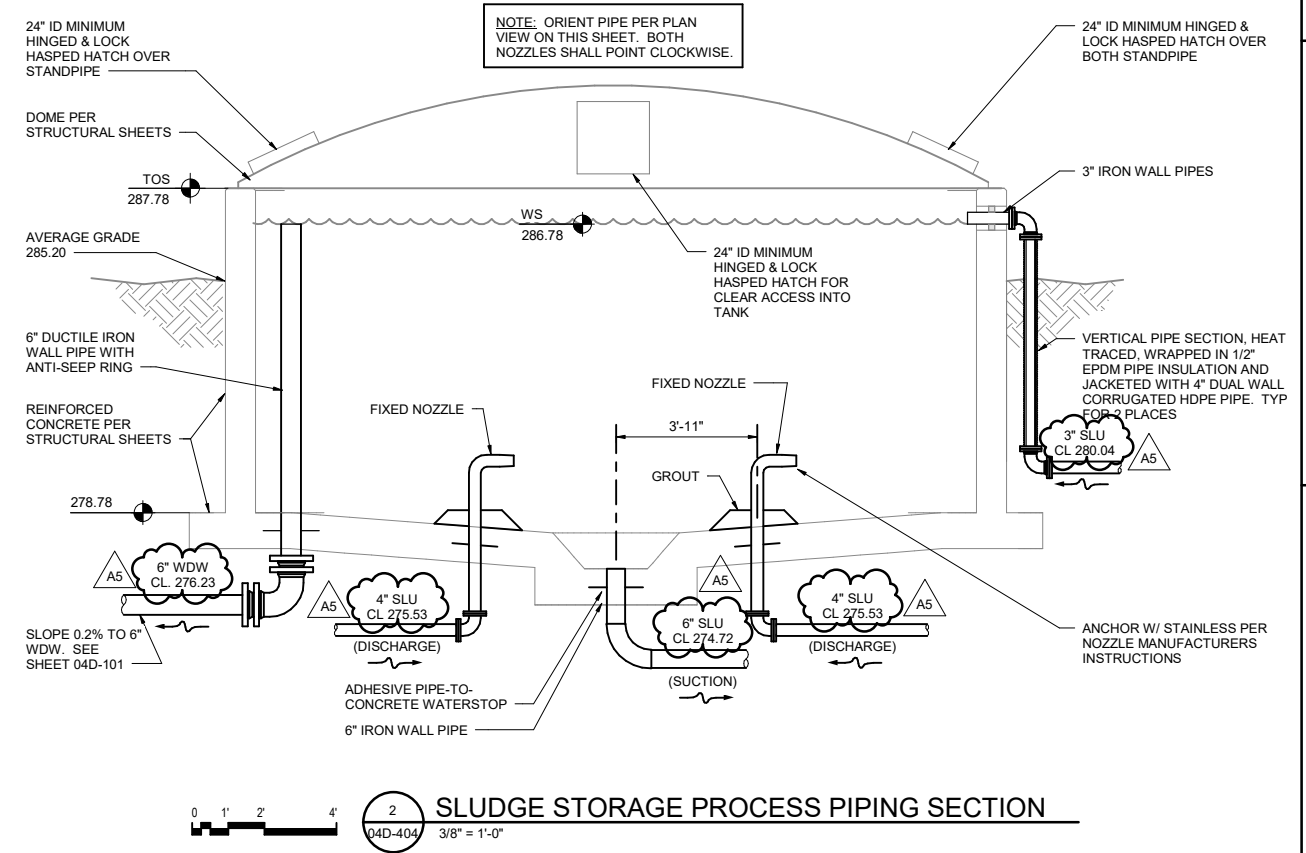

2 SLUDGE STORAGE PROCESS PIPING SECTION
04D-404 3/8" = 1'-0"

A:\desk_Docs\10357686_MainnaDIF_GrandLakeStream_Exp_2022\10357686-04-D.rvt 9/1/2023 4:56:38 PM



| | |
|-----------------|---------------|
| PROJECT MANAGER | ANDREW GURSKI |
| CIVIL | J. GAGNON |
| STRUCTURAL | B. BRADLEY |
| ARCHITECTURAL | M. BASKIN |
| PROCESS | J. CHANDLER |
| MECHANICAL | J. CHANDLER |
| ELECTRICAL | A. KANER |
| PROJECT NUMBER | 10357686 |

| A5 | 08/31/2023 | ADDENDUM 5 |
|-------|------------|----------------|
| | 07/14/2023 | ISSUED FOR BID |
| ISSUE | DATE | DESCRIPTION |

IMPROVEMENTS AT GRAND LAKE STREAM STATE FISH HATCHERY

SLUDGE STORAGE PROCESS PIPING PLAN & DETAILS

0 1 2
FILENAME | 10353741-04-D.rvt
SCALE | 3/8" = 1'-0"

SHEET
04D-404

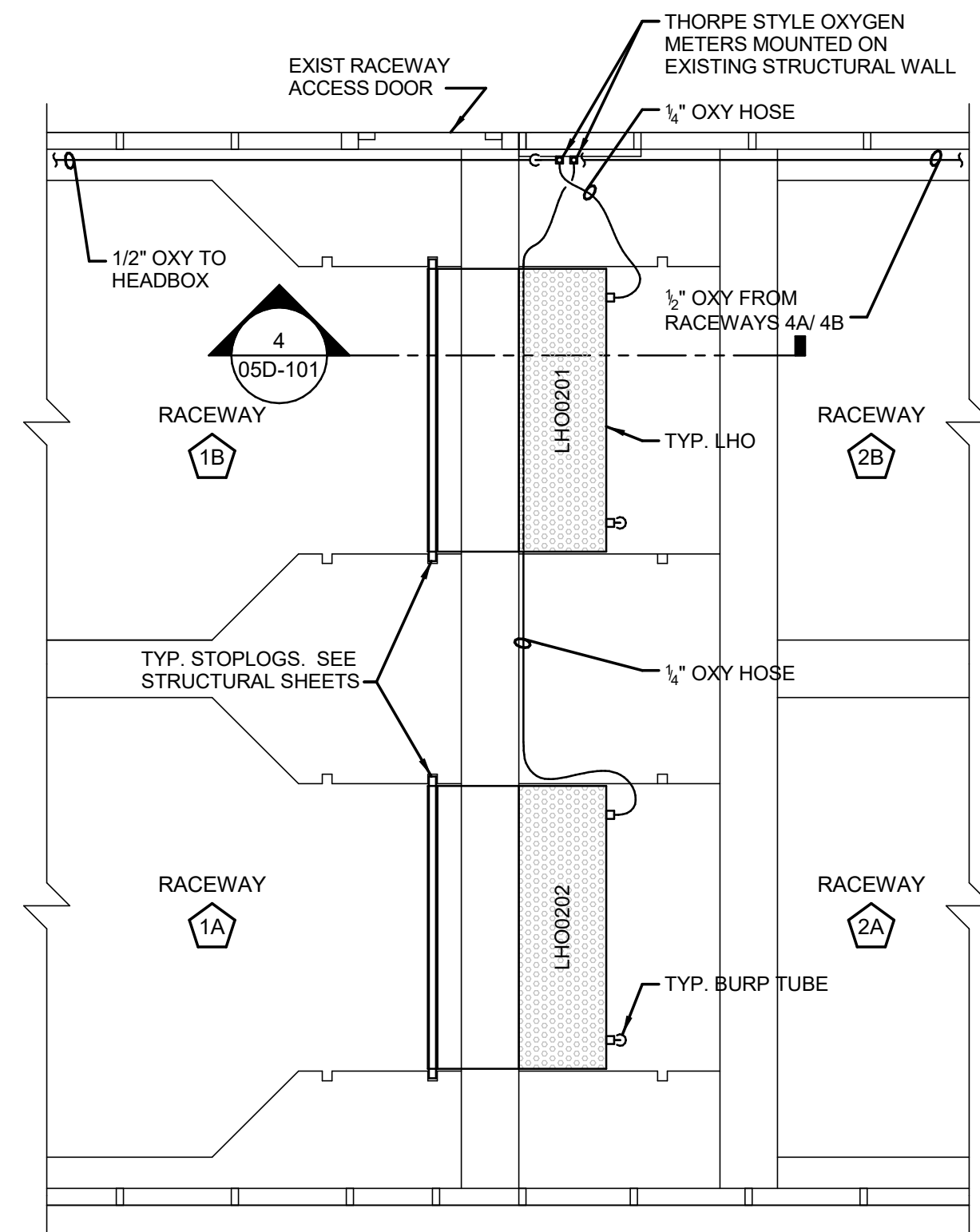

1 RACEWAYS 1A, 1B, 2A & 2B LHO PLAN
SCALE: 3/8" = 1'-0"

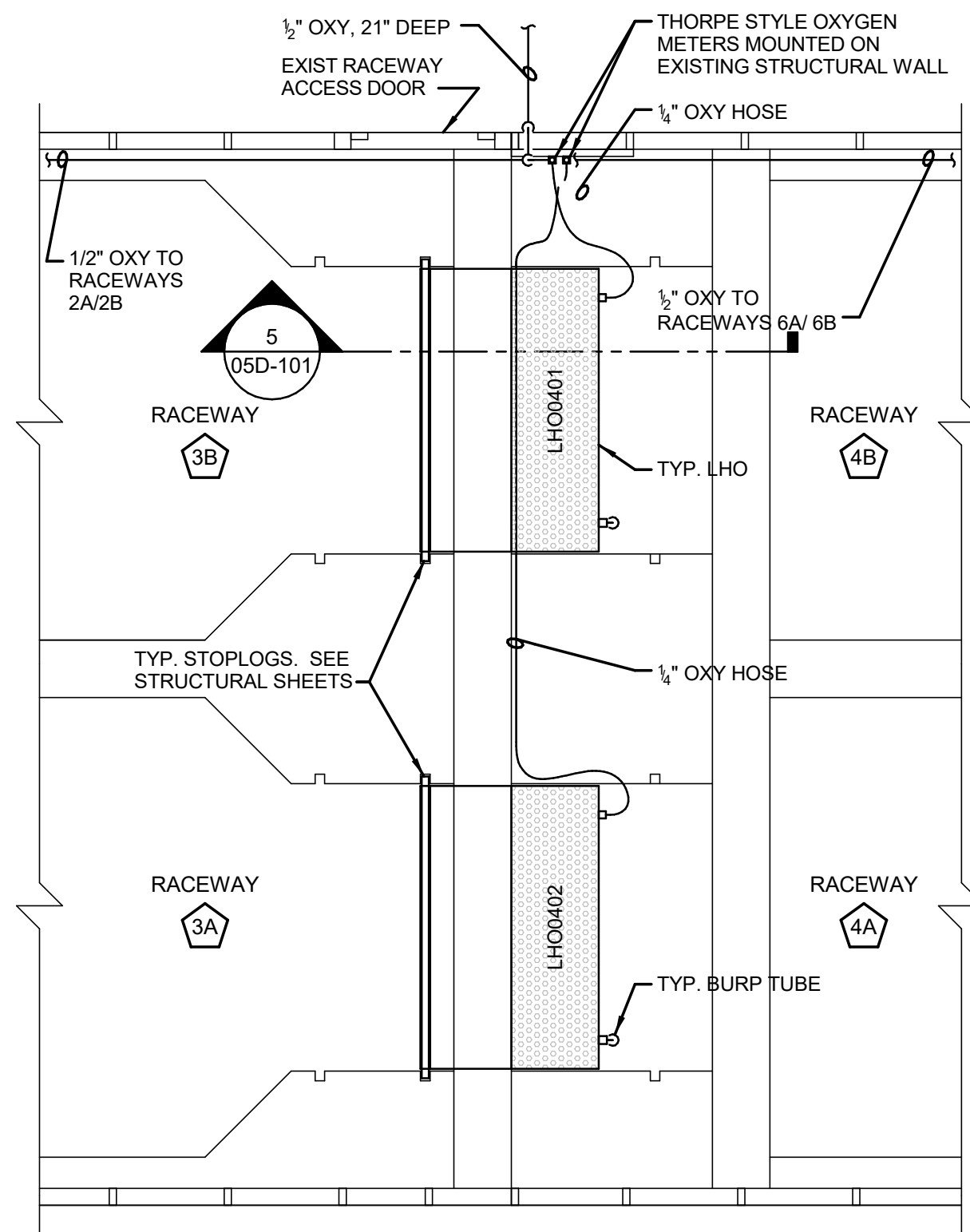
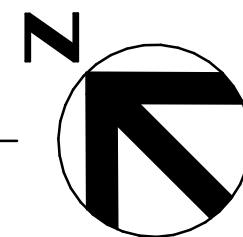

2 RACEWAYS 3A, 3B, 4A & 4B LHO PLAN
SCALE: 3/8" = 1'-0"

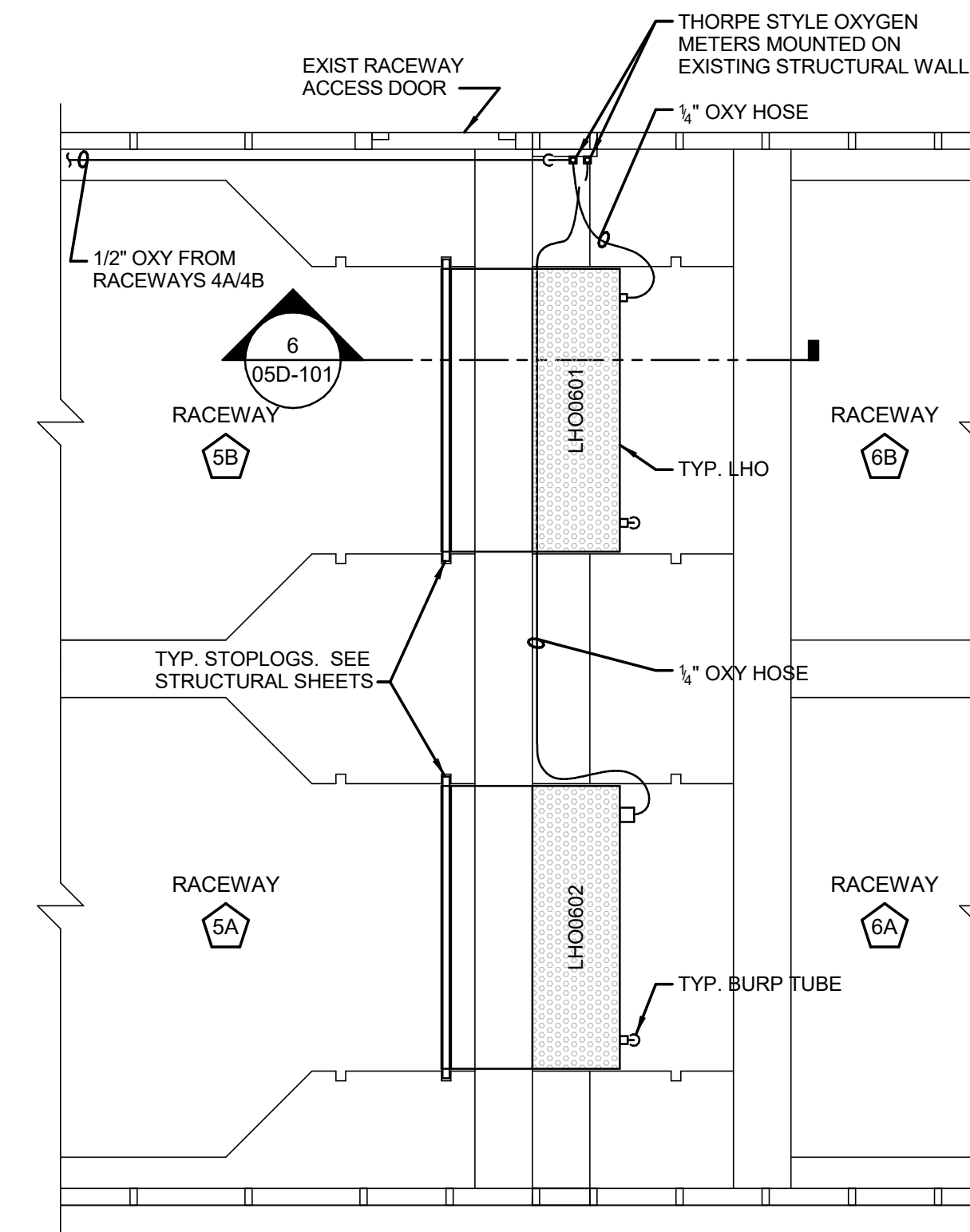
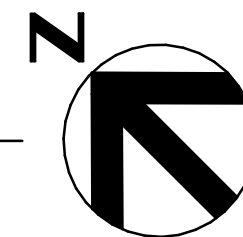

3 RACEWAYS 5A, 5B, 6A & 6B LHO PLAN
SCALE: 3/8" = 1'-0"

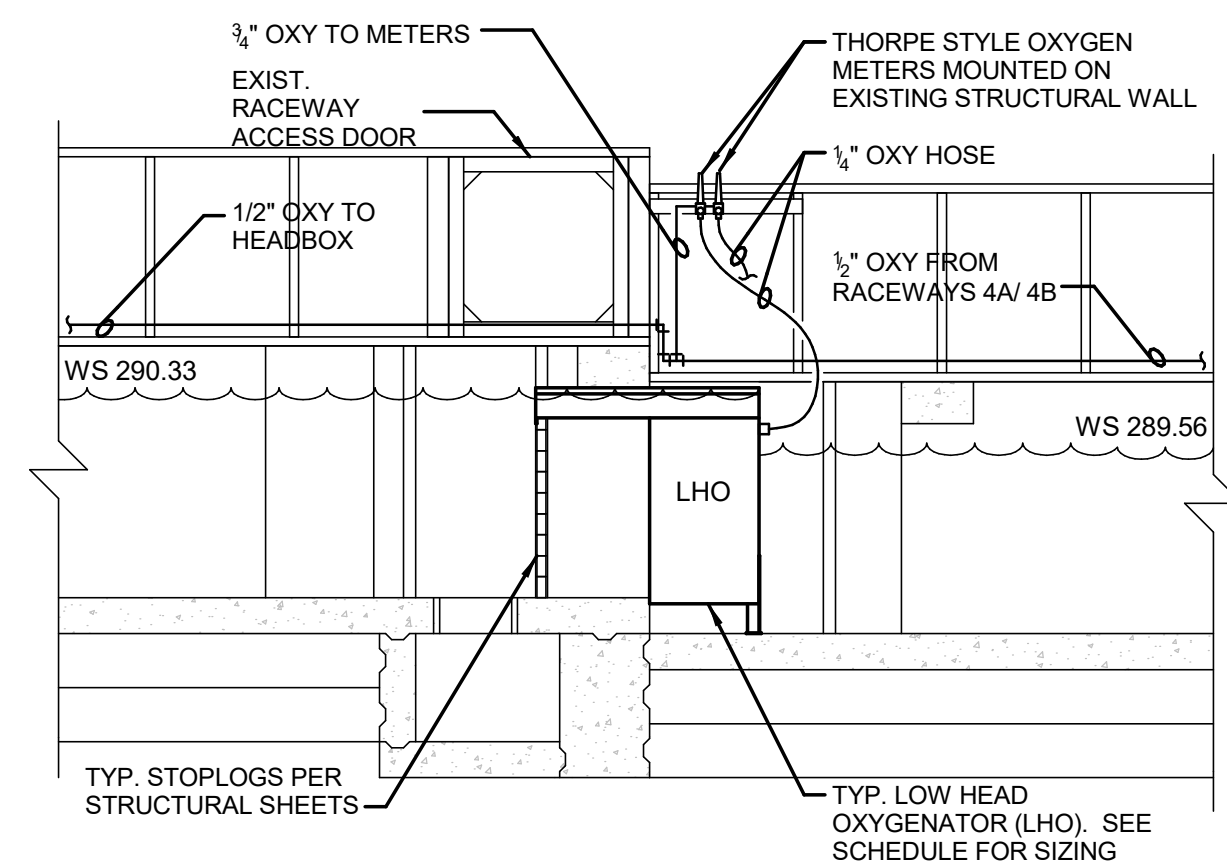
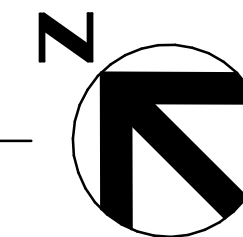

4 RACEWAY LHO SECTION
SCALE: 3/8" = 1'-0"

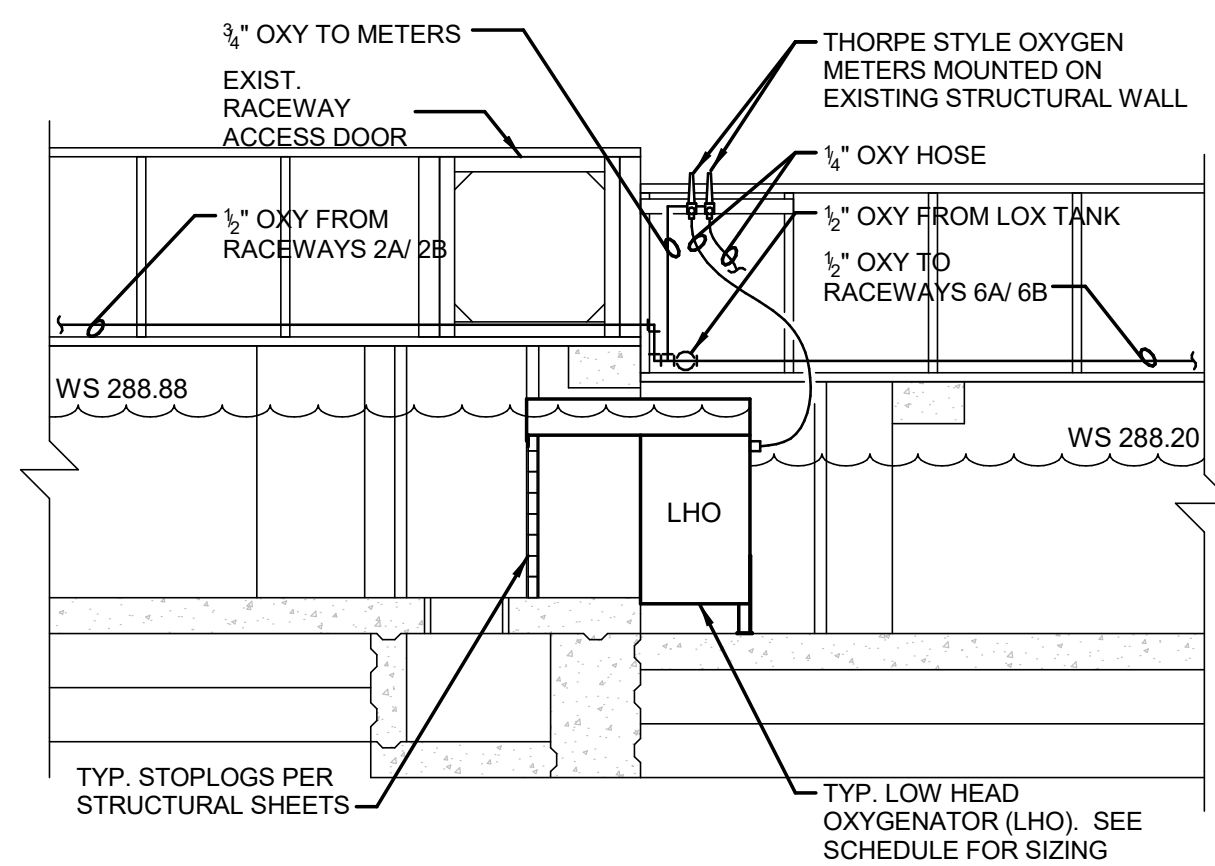

5 RACEWAY LHO SECTION
SCALE: 3/8" = 1'-0"

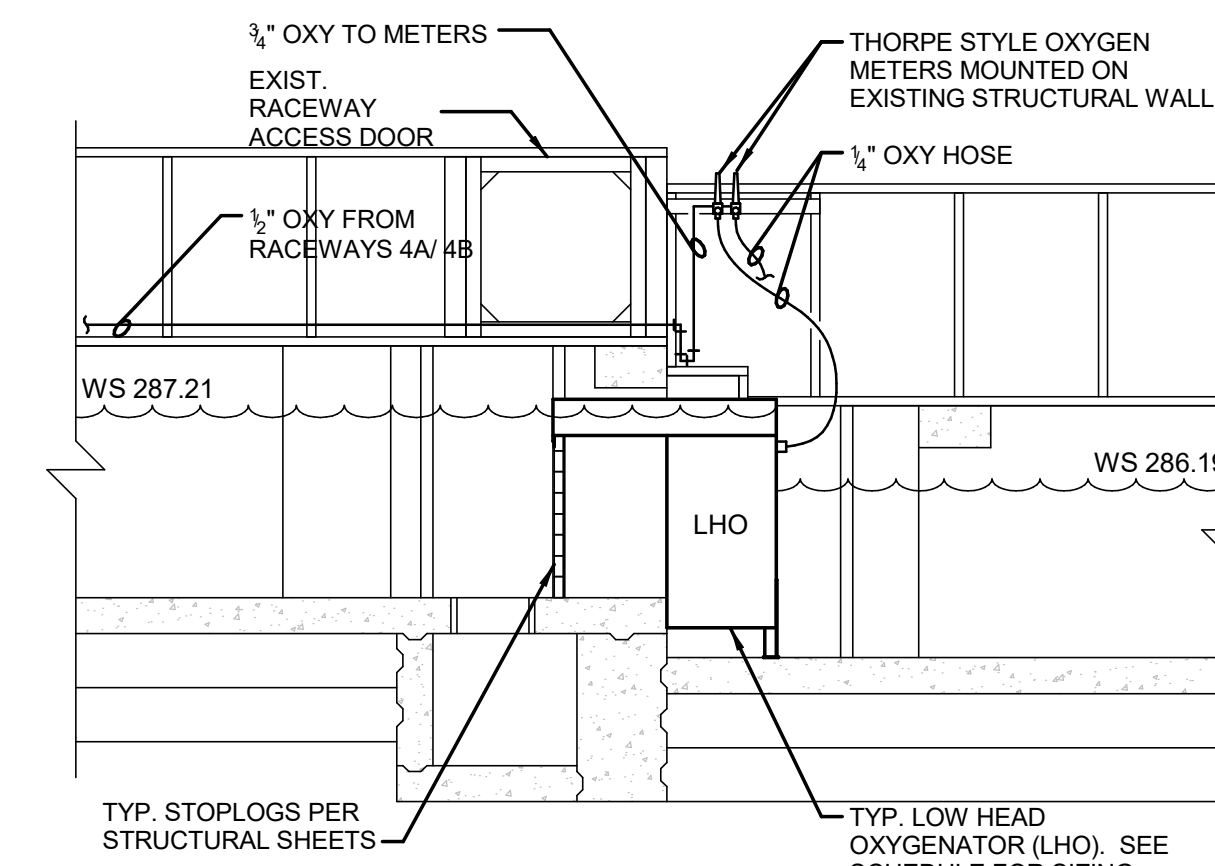

6 RACEWAY LHO SECTION
SCALE: 3/8" = 1'-0"

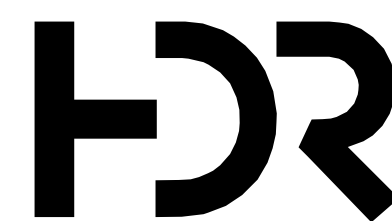

| ISSUE | DATE | DESCRIPTION |
|-------|------------|----------------|
| A5 | 08/31/2023 | ADDENDUM 5 |
| | 07/14/2023 | ISSUED FOR BID |

| | |
|-------------------------------|-------------|
| PROJECT MANAGER ANDREW GURSKI | |
| CIVIL | J. GAGNON |
| STRUCTURAL | B. BRADLEY |
| ARCHITECTURAL | M. BASKIN |
| PROCESS | J. CHANDLER |
| MECHANICAL | J. CHANDLER |
| ELECTRICAL | A. KANER |
| PROJECT NUMBER | 10357686 |

IMPROVEMENTS AT GRAND LAKE STREAM STATE FISH HATCHERY

EXISTING RACEWAYS LHO PIPING PLAN AND SECTIONS

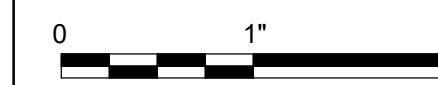

FILENAME 103537686-00-G.rvt
SCALE 3/8" = 1'-0"

