

GENERAL NOTES:

1. MODIFICATIONS TO ROOF FRAMING ARE DESIGNED FOR LOADINGS SPECIFIED IN THE 2015 EDITION OF THE INTERNATIONAL BUILDING CODE AND THE 2010 EDITION OF "MINIMUM DESIGN LOADS FOR BUILDINGS AND OTHER STRUCTURES" BY THE AMERICAN SOCIETY OF CIVIL ENGINEERS, ASCE7-10. ALTERATIONS ARE DESIGNED TO SUPPORT DEAD LOADS OF EXISTING AND NEW COMPONENTS AND SNOW LOADS AS FOLLOWS:
 - A. GROUND SNOW LOAD $P_g = 50$ PSF
 - B. EXPOSURE FACTOR $C_e = 1.0$
 - C. IMPORTANCE FACTOR $I_s = 1.2$
 - D. THERMAL FACTOR $C_t = 1.1$
 - E. FLAT ROOF SNOW LOAD $P_f = 46.2$ PSF
 - F. UNBALANCED AND DRIFTED SNOW IN ACCORDANCE WITH ASCE7-10.
2. DIMENSIONS INDICATED ON THE DRAWINGS AND OTHER EXISTING CONDITIONS INFORMATION ARE APPROXIMATE, PROVIDED FOR FRIGING. THE CONTRACTOR SHALL VERIFY ALL DIMENSIONS AND OTHER EXISTING CONDITIONS PRIOR TO PERFORMING AFFECTED AREAS OF THE WORK.
3. IT IS THE CONTRACTOR'S RESPONSIBILITY TO PROTECT THE BUILDING FROM DAMAGE DUE TO WATER INTRUSION, REMOVAL OF ROOF DECK, AND OTHER ACTIVITIES DURING CONSTRUCTION. TO THAT END, DECK REMOVAL ON ANY DAY SHALL BE LIMITED TO WHAT CAN BE REINSTALLED BEFORE LEAVING FOR THE DAY. THE ROOF SHALL HAVE WEATHER PROTECTION AT THE CLOSE OF EACH WORKDAY. THE CONTRACTOR SHALL MONITOR WEATHER CONDITIONS THROUGHOUT THE WORKDAY AND RESPOND TO ANY CHANGES IN WEATHER TO PROVIDE PROTECTION OF EXISTING INTERIORS THROUGHOUT THE WORKDAY AS WARRANTED. THE CONTRACTOR SHALL BE RESPONSIBLE FOR REPAIRS OF ANY DAMAGES THAT OCCUR AS A RESULT OF THE CONTRACTOR'S OPERATIONS DURING THE CONSTRUCTION PERIOD.
 - A. THE CONTRACTOR SHALL EXERCISE CAUTION IN LOADING THE ATTIC FLOOR/CEILING JOISTS WITH CONSTRUCTION MATERIALS AND EQUIPMENT. ANY DAMAGE CAUSED BY THE USE OF THE ATTIC AS A WORKING PLATFORM SHALL BE REPAIRED AT THE CONTRACTOR'S EXPENSE.
4. CONDUCT LOCALIZED DEMOLITION IN SUCH FASHION TO MINIMIZE DISTURBANCE OF ADJACENT AREAS. ANY AREAS AFFECTED BY CONSTRUCTION ACTIVITIES SHALL BE RETURNED TO CONDITION AS EXISTED PRIOR TO CONSTRUCTION.
5. REMOVAL OF ROOF DECK AT EAVES WILL BE NECESSARY TO INSTALL NEW FRAMING MEMBERS SPECIFIED TO BE SISTERED TO EXISTING RAFTERS. REMOVAL OF ROOF DECK WILL ALSO BE NECESSARY FOR HIP MEMBER REPLACEMENTS AND OTHER ASPECTS OF THE WORK INCLUDING LOADING MATERIALS INTO THE ATTIC. ADDITIONAL ROOF DECK REMOVAL IS ACCEPTABLE AS WARRANTED TO PERFORM SPECIFIED REINFORCEMENTS. TEMPORARY PROTECTION AND PERMANENT ROOF SHEATHING INSTALLATION SHALL COMPLY WITH NOTES AND SPECIFICATIONS AS STATED FOR OTHER AREAS.
6. WHERE WIRING AND SIMILAR EXISTING CONDITIONS OBSTRUCT THE SPECIFIED ALTERATIONS, TEMPORARILY RELOCATE THOSE ITEMS. DO NOT DISCONNECT ANY COMPONENT WITHOUT APPROVAL BY THE OWNER. REINSTALL AS APPROVED BY THE OWNER.
7. AT SOME LOCATIONS, IT WILL BE NECESSARY TO DISCONNECT FRAMING MEMBERS FROM SUPPORTS IN ORDER TO INSTALL SPECIFIED REINFORCEMENTS. THE CONTRACTOR WILL BE RESPONSIBLE FOR MAINTAINING STABILITY OF DISCONNECTED MEMBERS UNTIL FINAL CONNECTIONS ARE COMPLETED.

WOOD FRAMING NOTES:

1. "LVL" DESIGNATES LAMINATED VENEER LUMBER. PROVIDE BOISE CASCADE VERSA-LAM 2.0 3100 FRAMING. WHERE MEMBERS THICKER THAN 1-3/4" ARE SPECIFIED, PROVIDE SINGLE MEMBERS FABRICATED TO THE SPECIFIED THICKNESS. JOINING MULTIPLE MEMBERS TO ATTAIN THE SPECIFIED THICKNESS IS NOT ACCEPTABLE UNLESS SPECIFICALLY APPROVED AS A SUBSTITUTION.
2. NEW DIMENSION LUMBER SHALL BE #2 GRADE OR BETTER SPRUCE-PINE-FIR GRADED UNDER NLSA RULES.
3. WHERE NAILS ARE SPECIFIED, PROVIDE FASTENERS WITH THE FOLLOWING MINIMUM DIMENSIONS:
 - A. 10d NAILS USED FOR FASTENING ROOF SHEATHING = 0.148" DIAMETER X 3"
 - B. 10d NAILS USED FOR FRAMING = 0.12" DIAMETER X 2-7/8"
 - C. 16d NAILS = 0.148" X 3-1/4"
 - D. 8d NAILS = 0.113" DIAMETER X 2-3/8"
4. PROVIDE FASTENERS FOR CONNECTING WOOD FRAMING AS INDICATED. WHERE NOT INDICATED, COMPLY WITH TABLE 2304.10.1 IN THE 2015 EDITION OF THE INTERNATIONAL BUILDING CODE.
5. INSTALL TOENAILS AT AN ANGLE 30 DEGREES FROM THE AXIS OF THE SUPPORTED MEMBER. INSTALL WITH THE TIP LOCATED AT A DISTANCE OF 1/3 OF THE NAIL LENGTH FROM THE END OF THE SUPPORTED MEMBER.
6. LAG SCREWS SHALL COMPLY WITH ANSI/ASME B18.2.1, FOR 5/8" DIAMETER LAG SCREWS, THE MAXIMUM PILOT HOLE FOR THE THREADED PORTION OF THE SCREW SHALL BE 70% OF THE SHANK DIAMETER.
7. WHERE PROPRIETARY CONNECTORS ARE SPECIFIED, INSTALL IN ACCORDANCE WITH THE MANUFACTURER'S SPECIFICATIONS. USE ALL SPECIFIED FASTENERS WITHOUT SUBSTITUTION UNLESS OTHERWISE NOTED ON THE DRAWINGS. WHERE MORE THAN ONE FASTENER SPECIFICATION EXISTS, INSTALL THE MAXIMUM FASTENING UNLESS OTHERWISE NOTED.
8. BOLTS SPECIFIED FOR CONNECTING TIMBER MEMBERS AND FOR CONNECTING TIMBER MEMBERS TO STEEL SHALL BE ASTM A307 BOLTS. INSTALL WITH DRILLED HOLES 1/16" LARGER THAN THE BOLT DIAMETER.

STRUCTURAL STEEL NOTES:

1. ALL STEEL WORK SHALL CONFORM TO THE 14TH EDITION OF THE SPECIFICATION FOR STRUCTURAL STEEL BUILDINGS BY THE AMERICAN INSTITUTE OF STEEL CONSTRUCTION, ANSI/AISC 360-10.
2. SUBMIT SHOP DRAWINGS FOR STRUCTURAL STEEL COMPONENTS. NOTE THAT ALL DIMENSIONS FOR MEMBER LENGTHS AND CONNECTIONS MUST BE DERIVED FROM FIELD MEASUREMENTS OF EXISTING CONSTRUCTION.
3. ALL WELDING SHALL BE DONE BY A WELDER CERTIFIED BY THE AMERICAN WELDING SOCIETY FOR THE WELDING PROCEDURE AND POSITIONS UTILIZED.
4. ALL WELDING SHALL BE IN COMPLIANCE WITH AWS D11 STRUCTURAL WELDING - STEEL BY THE AMERICAN WELDING SOCIETY, LATEST EDITION.
5. NO FIELD WELDING IS PERMITTED IN THE ATTIC.
6. STRUCTURAL STEEL WIDE FLANGE SHAPES SHALL BE ASTM A992. STRUCTURAL STEEL ANGLES, CHANNELS, PLATES, AND CLEVIS PINS SHALL BE ASTM A36.
7. CLEVISSES SHALL HAVE A MINIMUM RATED WORKING STRENGTH OF 25,000 LBS. (ALLOWABLE STRESS DESIGN). TURNBUCKLES SHALL HAVE A MINIMUM RATED WORKING STRENGTH OF 15,500 LBS. (ALLOWABLE STRESS DESIGN).

ROOF DECK NOTES:

1. AT AREAS WHERE 1" EXISTING BOARD SHEATHING IS REMOVED, INFILL WITH APA RATED SHEATHING WITH THICKNESS TO MATCH EXISTING DECK. INSTALL WITH LONG DIMENSION PERPENDICULAR TO SUPPORTS. FASTEN TO SUPPORTS WITH 10d NAILS AT 6" ON CENTER.

NO.	DATE	REVISION

**BOLDUC CORRECTONAL FACILITY
ADMIN BUILDING ROOF PLAN**

WARREN, MAINE

GENERAL STRUCTURAL NOTES

DRAWN BY: SJM
 CHECKED BY: MAC
 ISSUE DATE: 5-22-2023
 PROJ. NO.: 2022.053

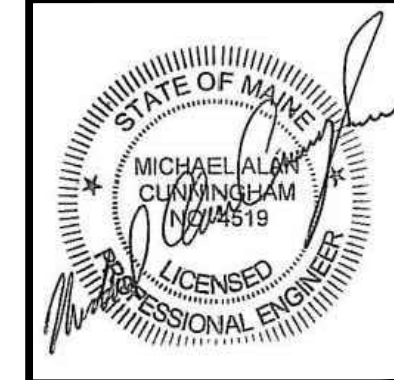

Lincoln / Haney
Engineering Associates, Inc.

14 Maine Street, Suite 306A
Brunswick, Maine 04011
Phone: 207-729-1061 Fax: 207-729-2941

S0.1

SHEET NOTES:

1. SEE SHEET S0.1 FOR GENERAL STRUCTURAL NOTES.

KEY NOTES:

- ① ADD 3/4"x11 1/8" LVL BENEATH EXISTING (2)-2X12 BEAM
- ② REMOVE EXISTING 2X12 HIP BEAM & INSTALL NEW (3)-1 3/4"x11 1/8" LVL HIP BEAM
- ③ REINFORCE EXISTING TRUSSES

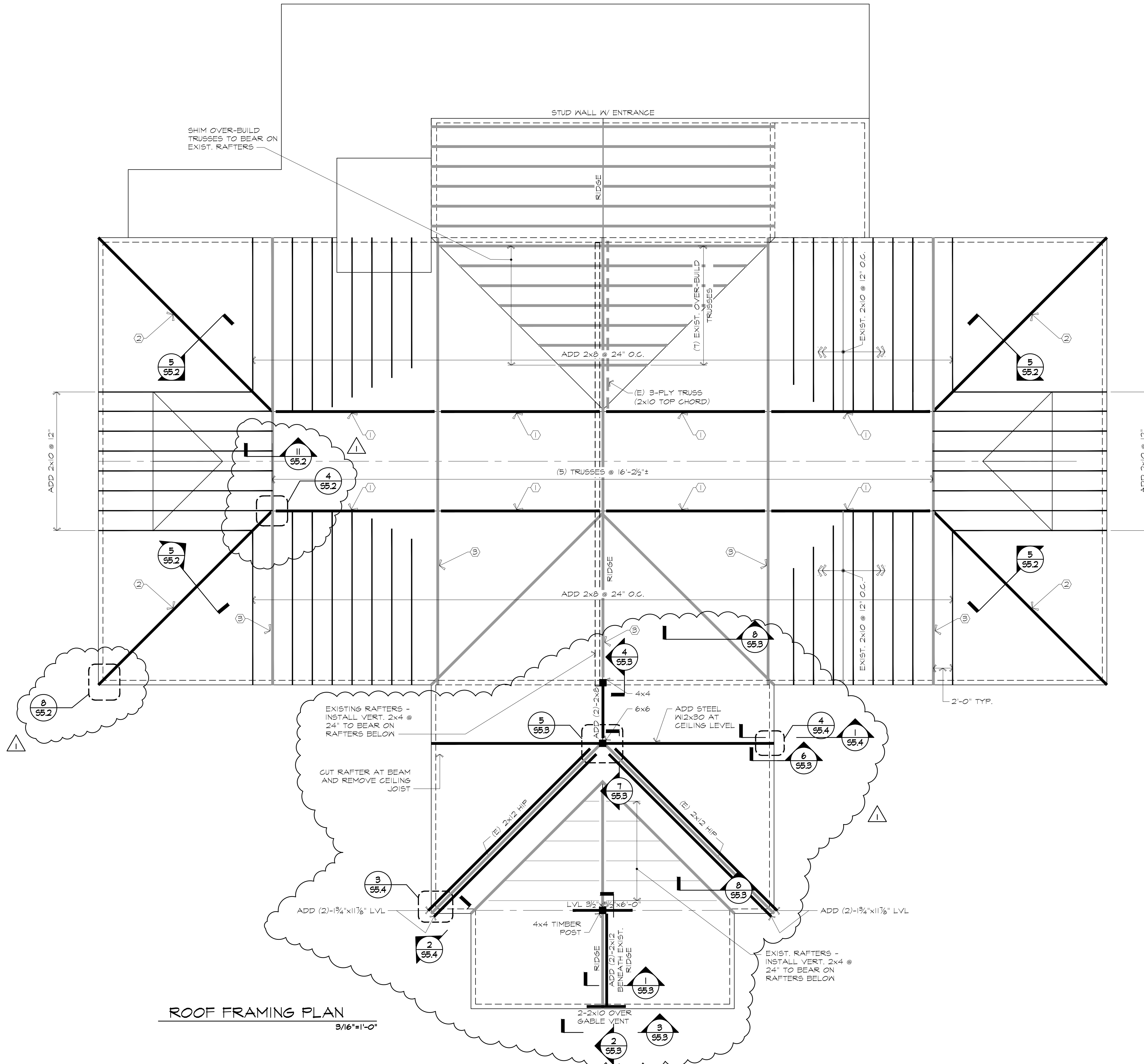

ROOF FRAMING PLAN
3/16"=1'-0"

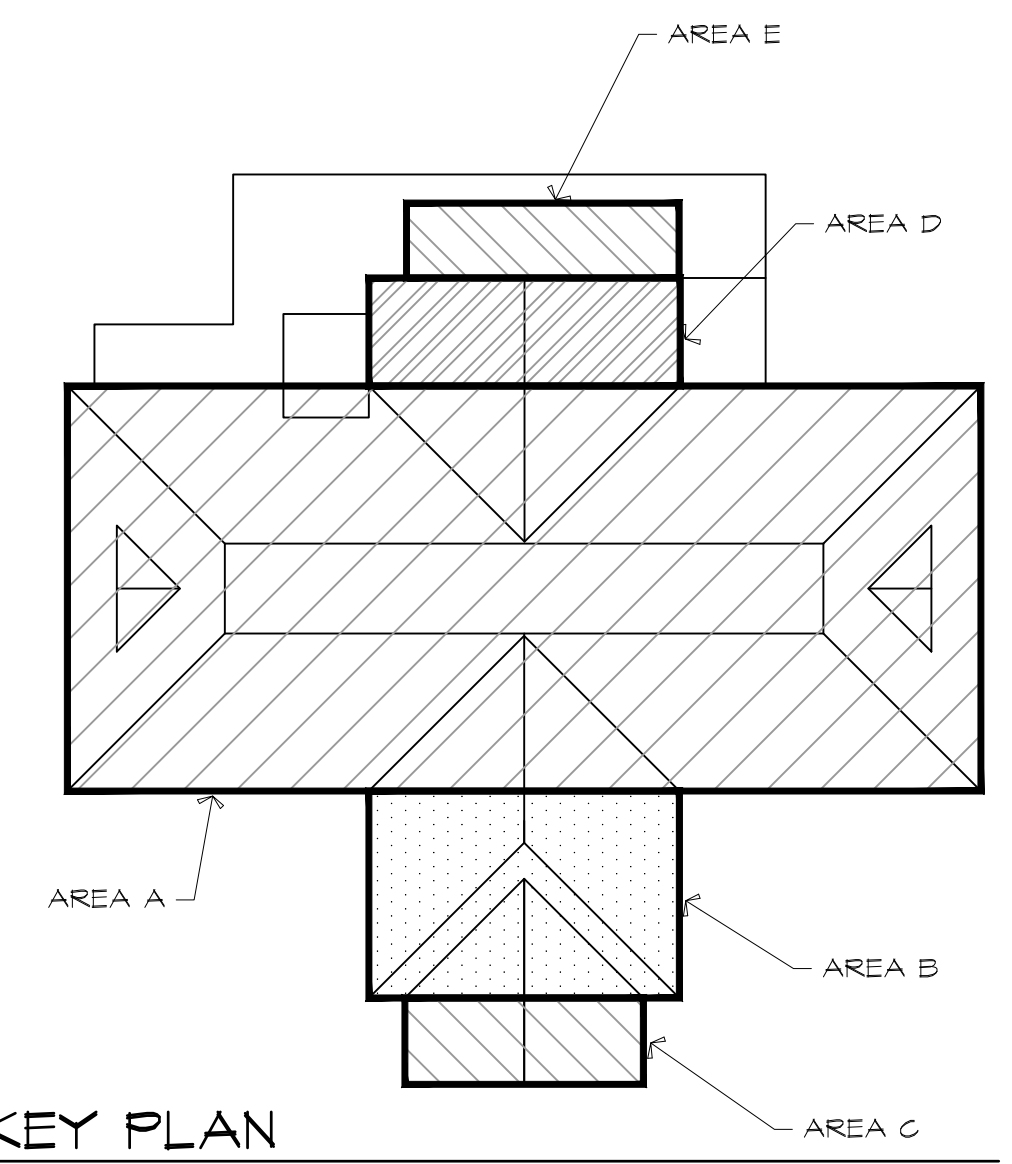

KEY PLAN

NO.	DATE	REVISION
1	6-9-23	APPENDUM No. 1

BOLDUC CORRECTIONAL FACILITY
ADMIN BUILDING ROOF PLAN
WARREN, MAINE

DRAWN BY: SJM
CHK'D BY: MAC
ISSUE DATE: 5-22-2023
PROJ. NO.: 2022.053

ROOF FRAMING PLAN

Lincoln / Haney
Engineering Associates, Inc.
14 Maine Street, Suite 306A
Brunswick, Maine 04011
Phone: 207-729-1061 Fax: 207-729-2941

S1.1

NTS

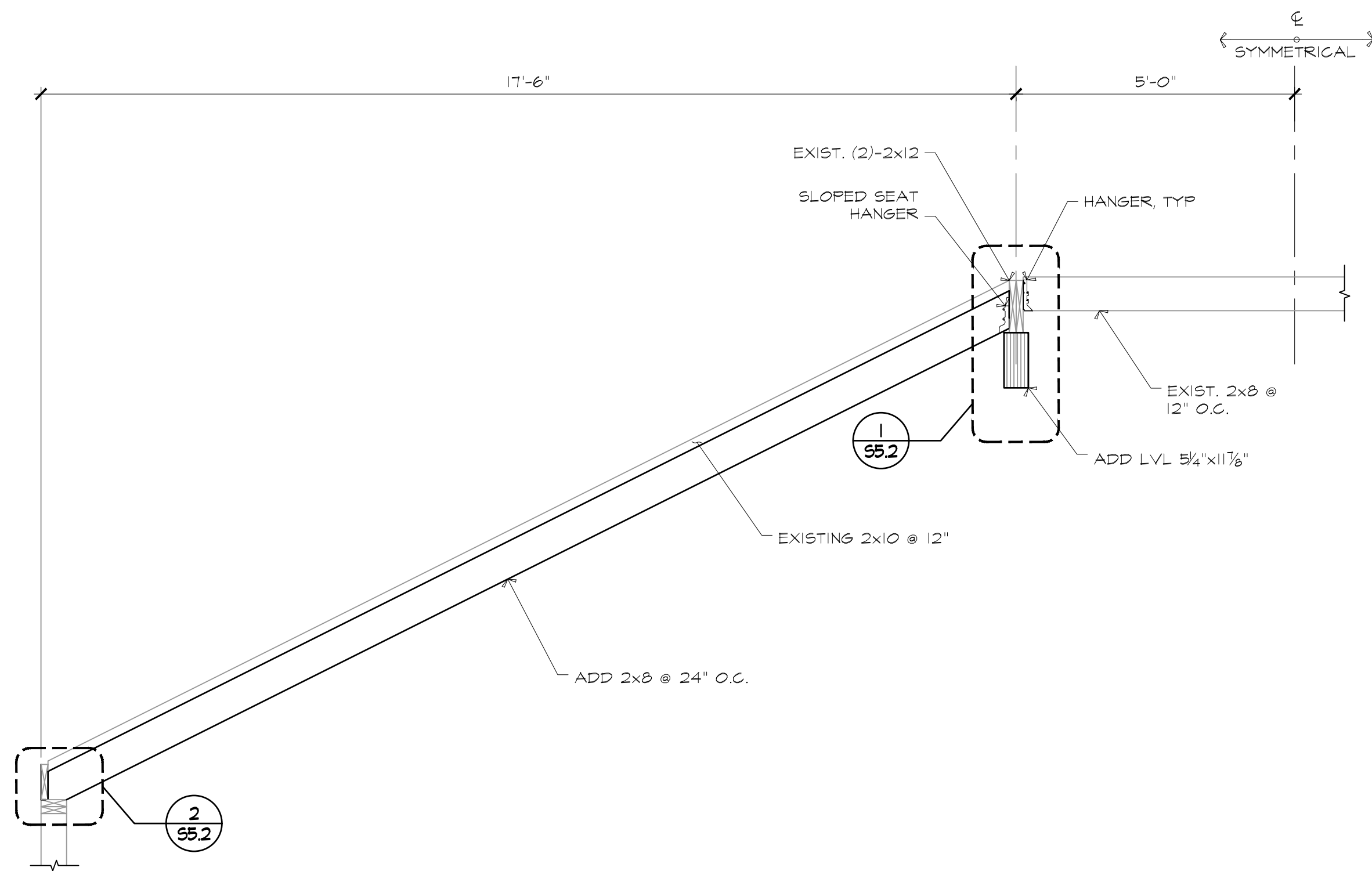

1 TYPICAL AREA A ROOF X-SECTION
1/2"=1'-0"

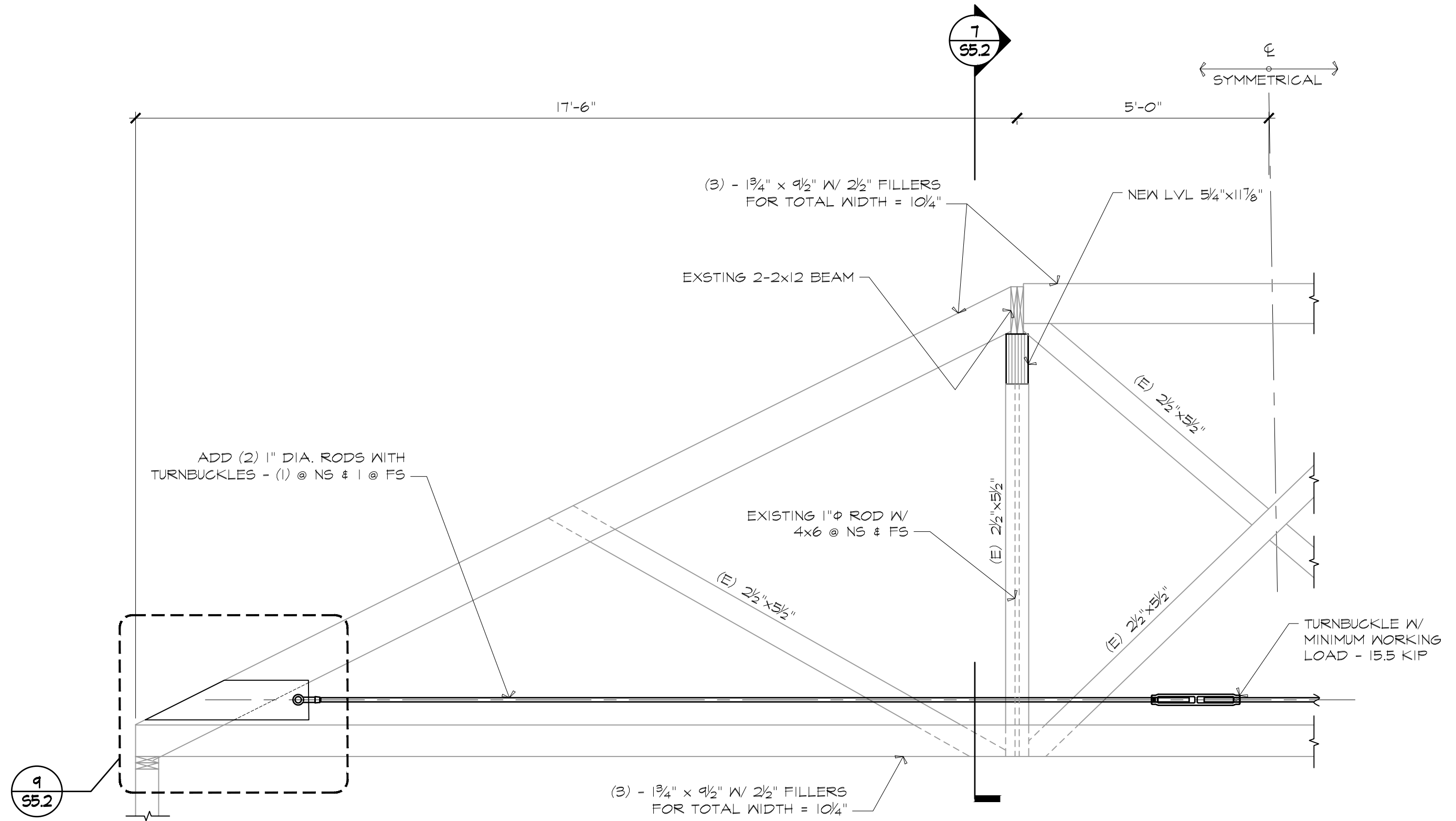

2 TYPICAL AREA A TRUSS REINFORCEMENT DETAIL
1/2"=1'-0"

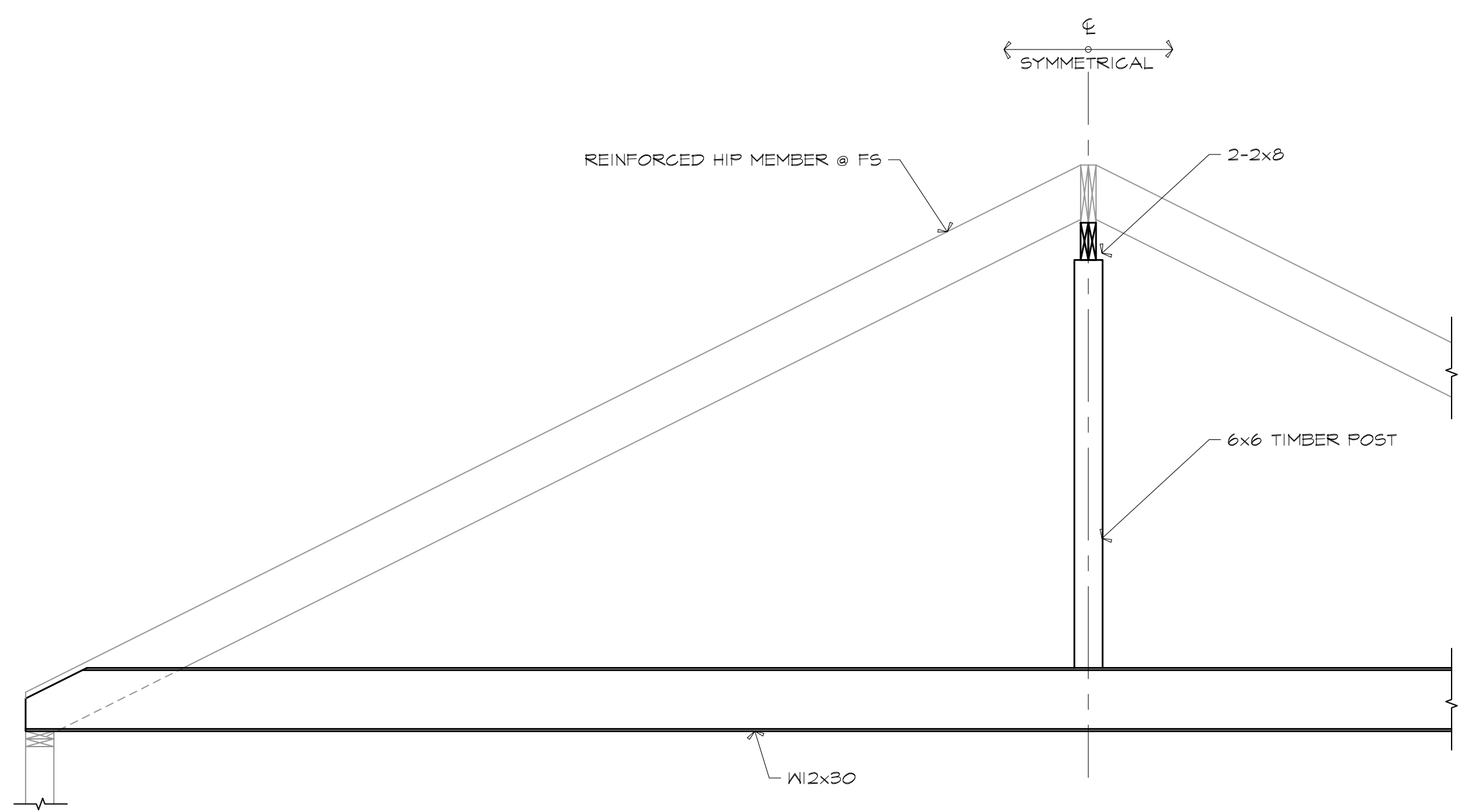

3 AREA B REINFORCEMENT DETAIL
1/2"=1'-0"

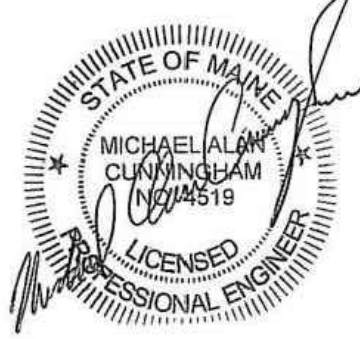
REVISION	
DATE	
NO.	
BOLDUC CORRECTIONAL FACILITY ADMIN BUILDING ROOF PLAN WARREN, MAINE	
FRAMING SECTIONS & DETAILS	
DRAWN BY	SJAM
CHECKED BY	M/AC
ISSUE DATE	5-22-2023
PROJ. NO.	2022.053
	
Lincoln / Haney Engineering Associates, Inc. 14 Maine Street, Suite 306A Brunswick, Maine 04011 Phone: 207-729-1061 Fax: 207-729-2941	
<h1>S5.1</h1>	

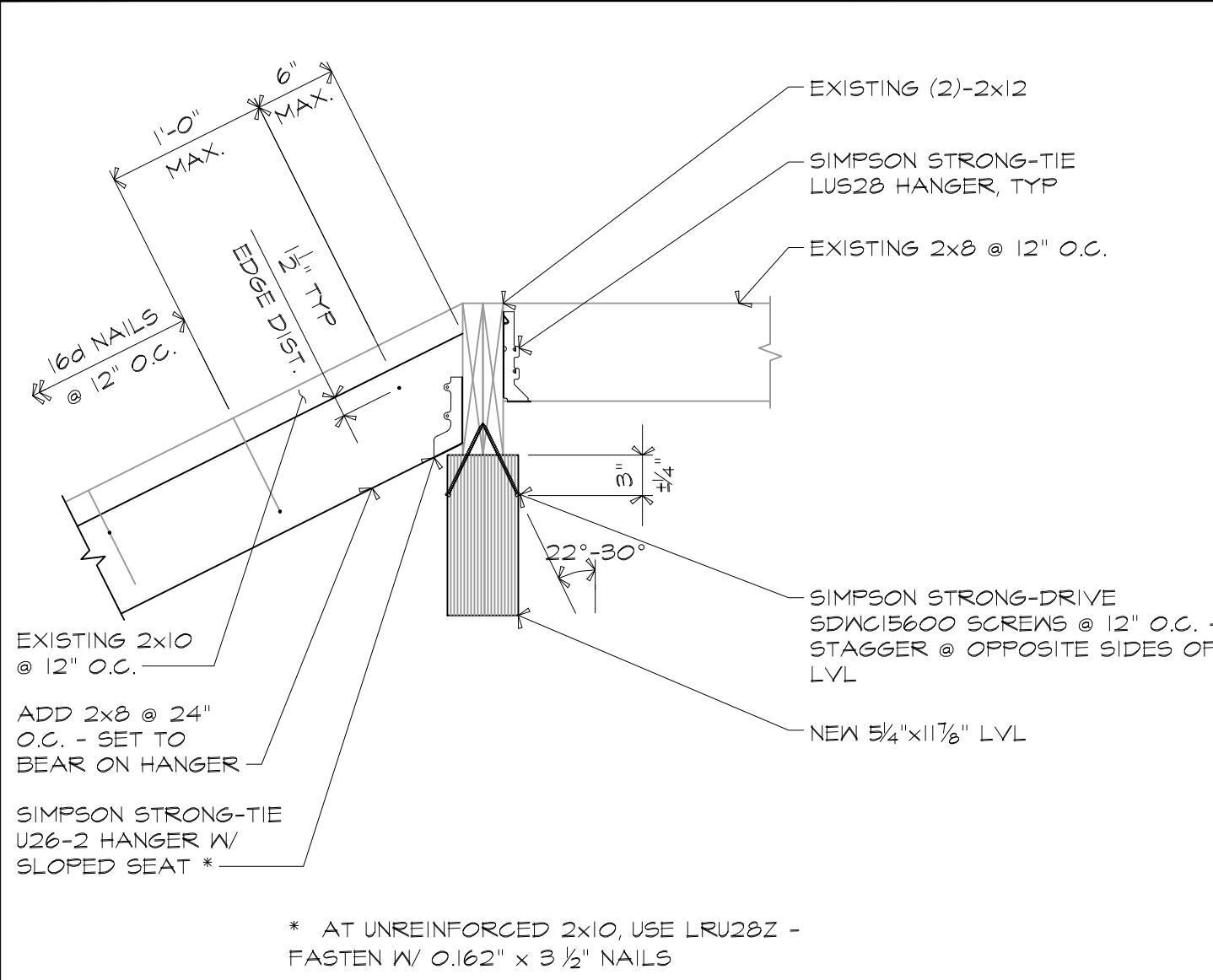

1 DETAIL 1"=1'-0"

NOTE: PROVIDE TEMPORARY SUPPORT FOR EXISTING RAFTERS BEFORE REMOVAL OF EXISTING HIP MEMBER. MAINTAIN TEMPORARY SUPPORT UNTIL NEW HIP BEAM & CONNECTORS ARE INSTALLED, BUT BACK EXISTING RAFTERS TO FIT TIGHT TO NEW HIP.

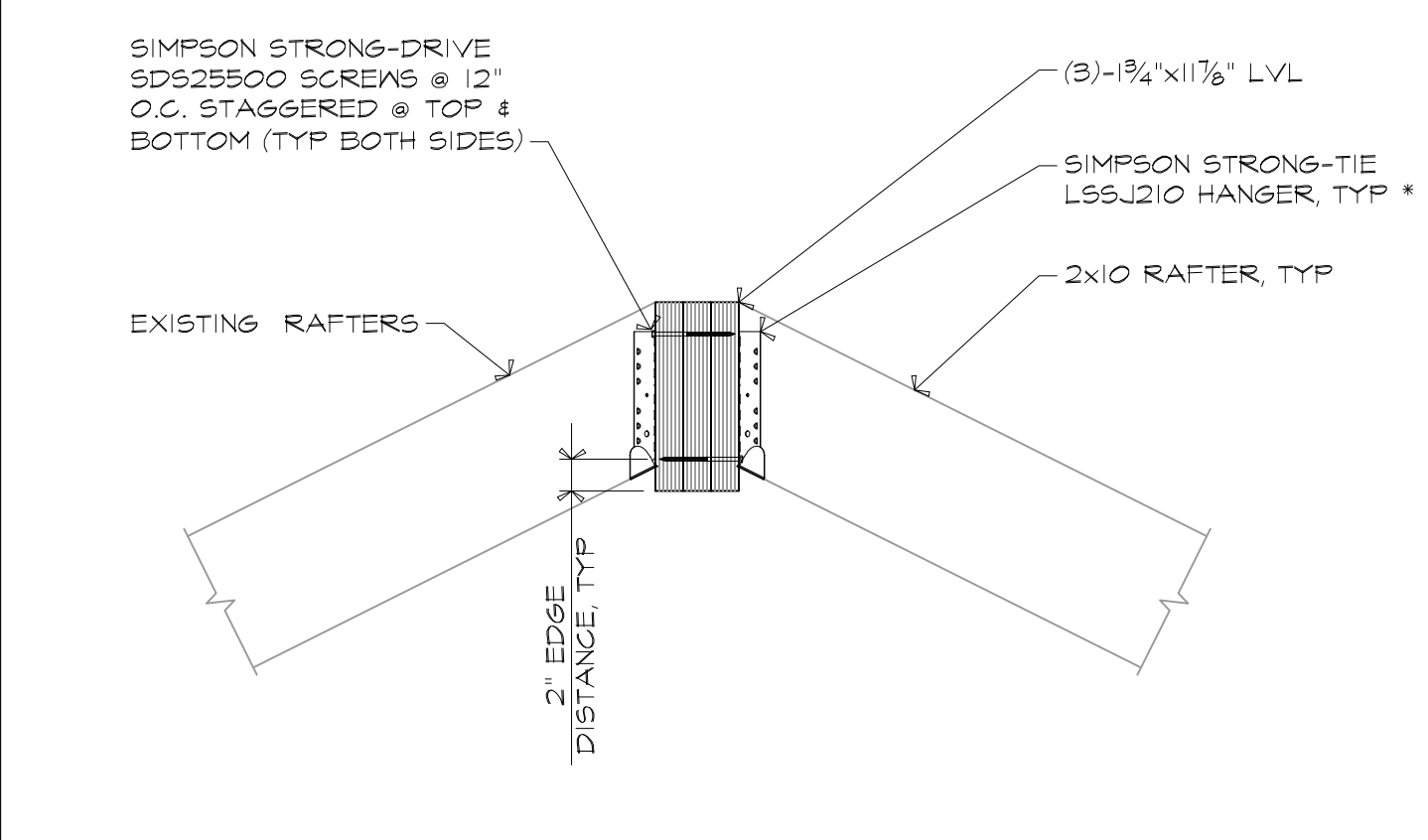

5 SECTION 1"=1'-0"

* AT SISTERED RAFTER, USE SIMPSON STRONG-TIE LSSR210-22

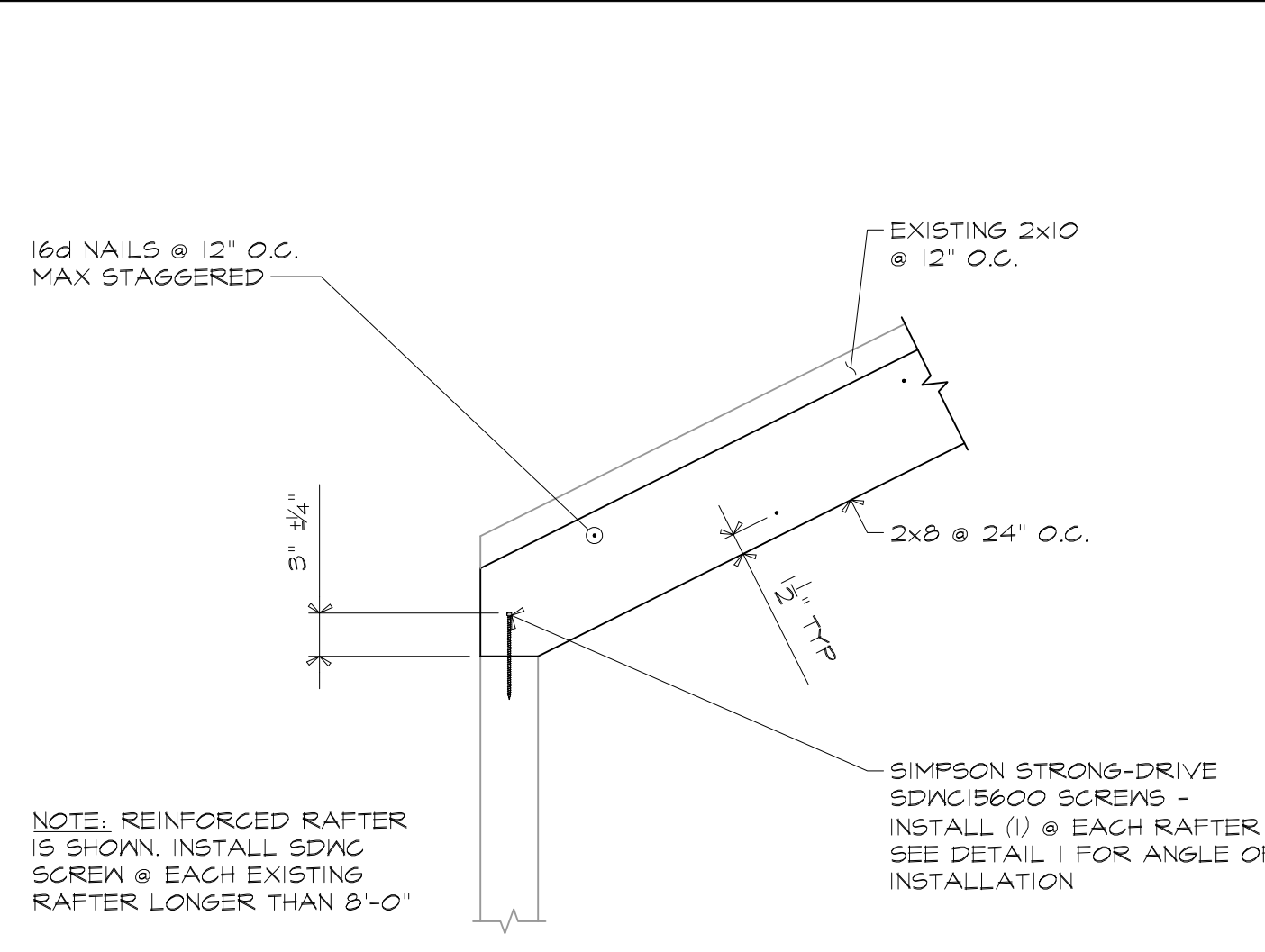

2 DETAIL 1"=1'-0"

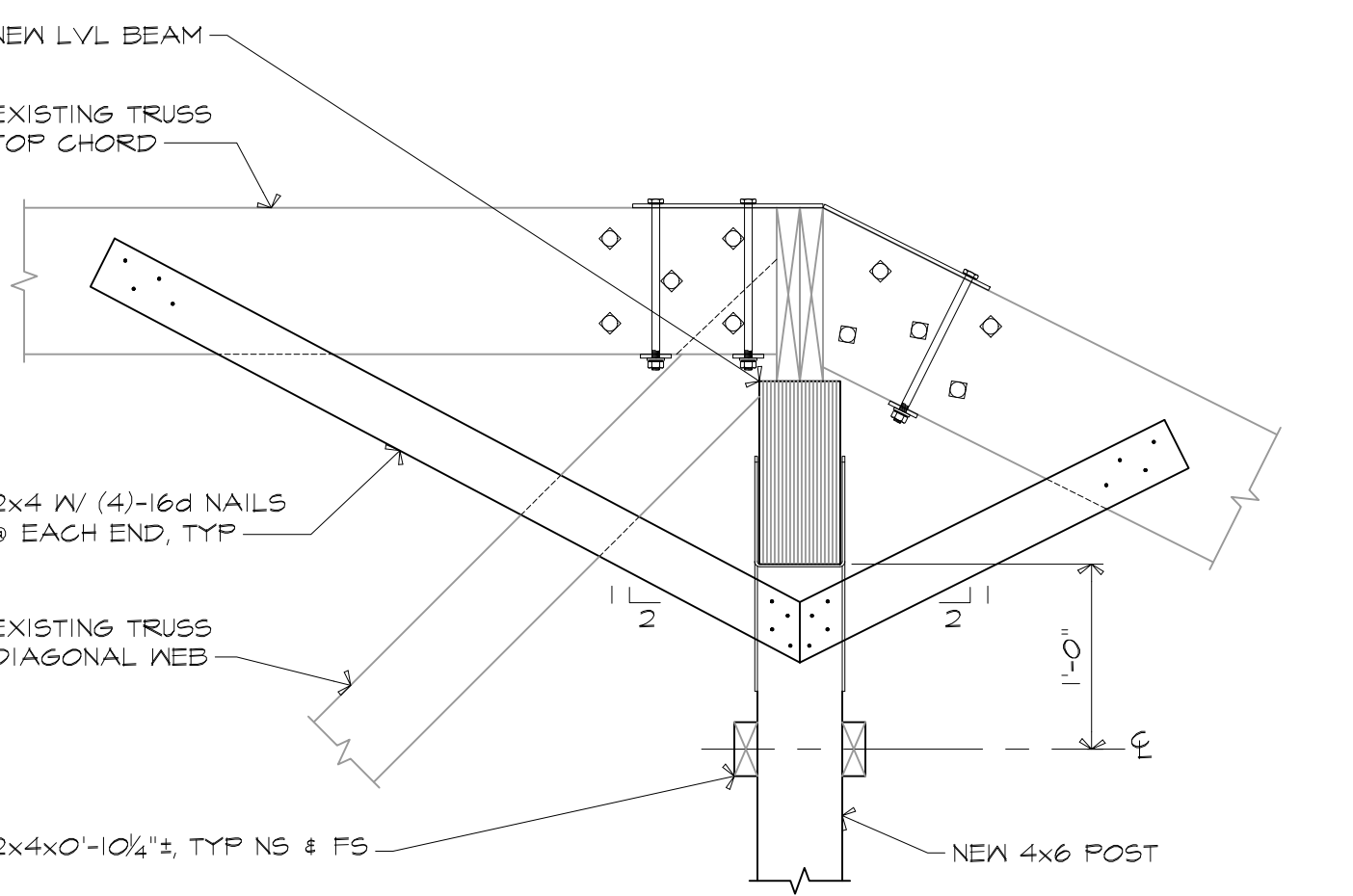

6 SECTION 1"=1'-0"

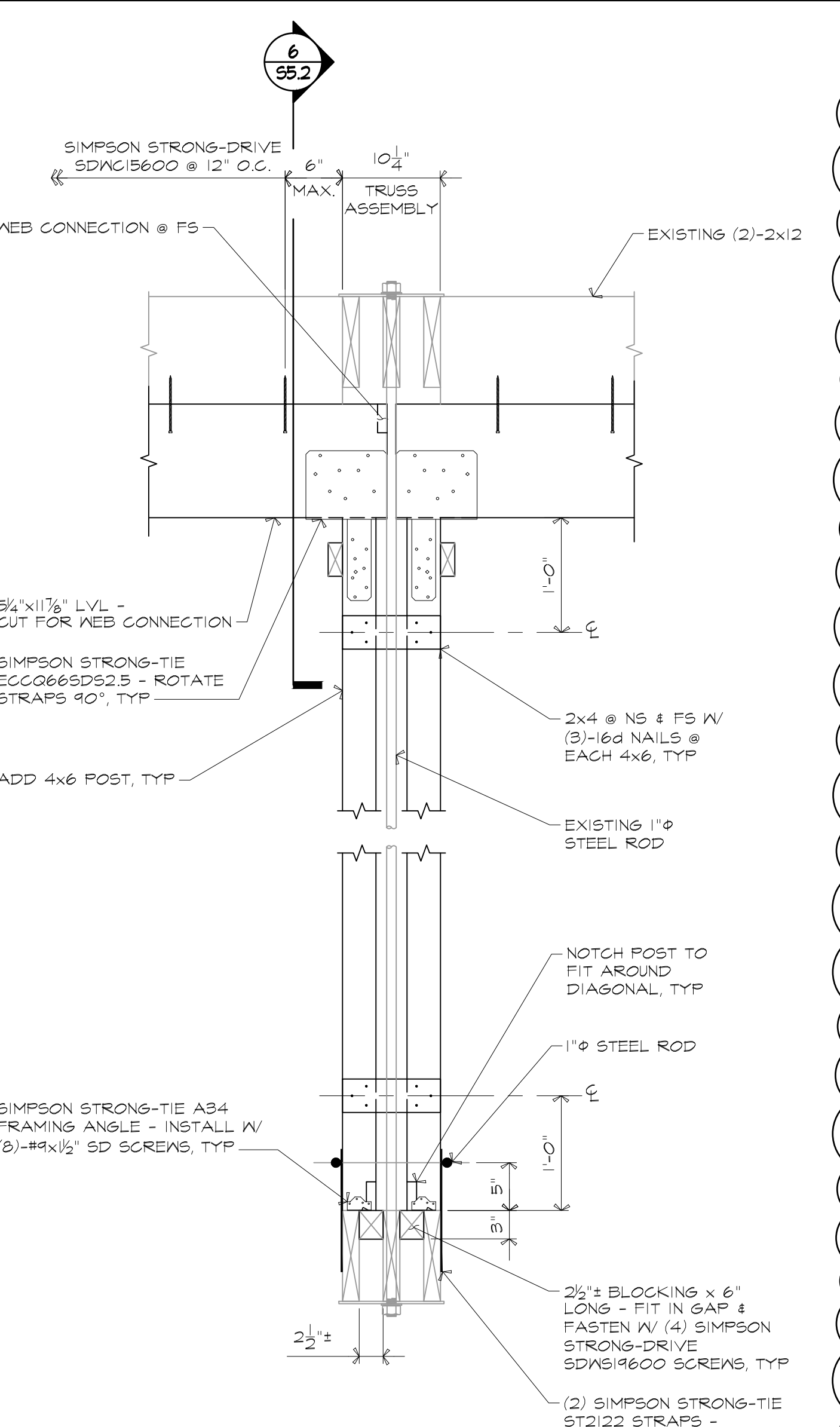

7 SECTION 1"=1'-0"

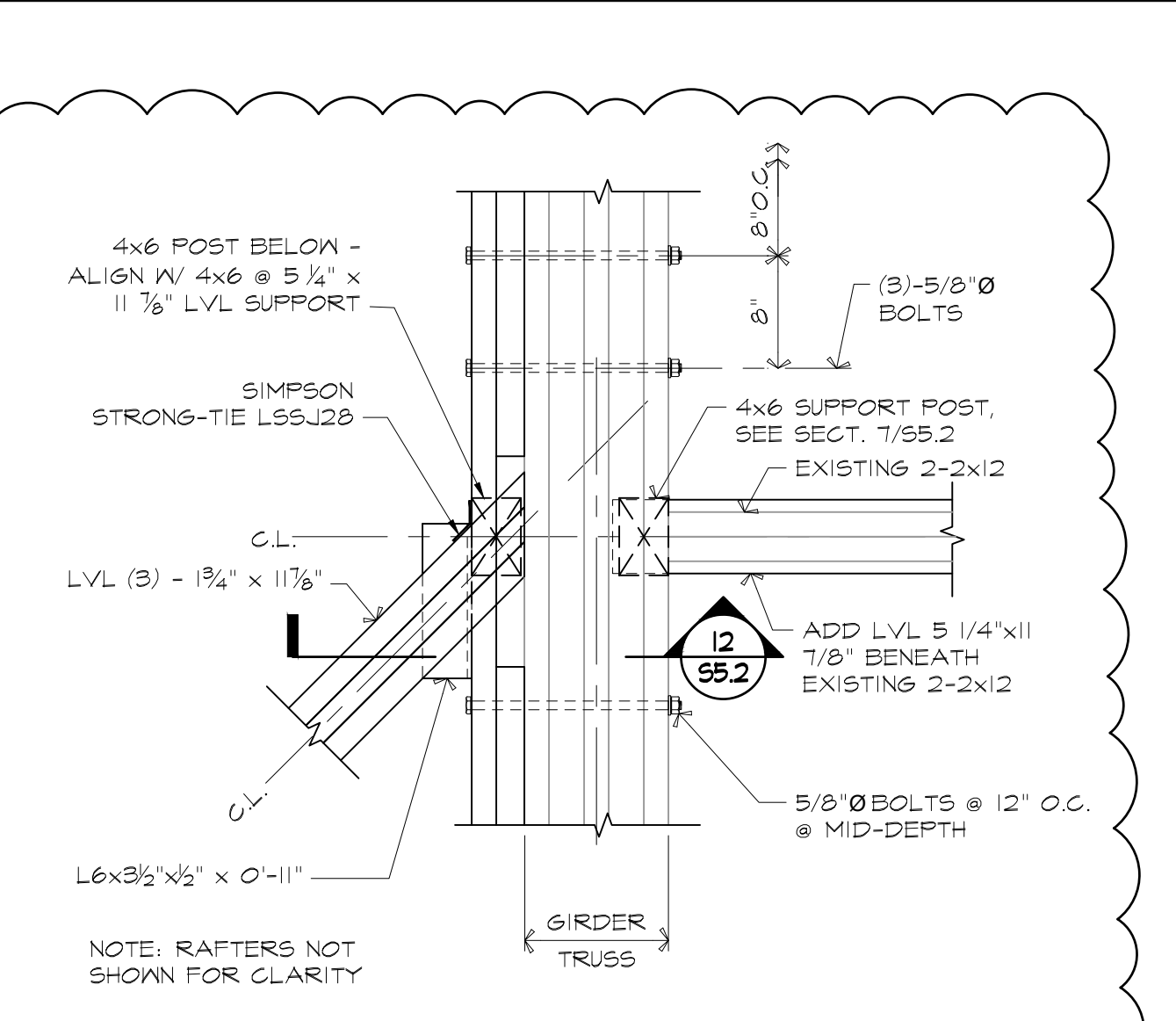

4 DETAIL 1"=1'-0"

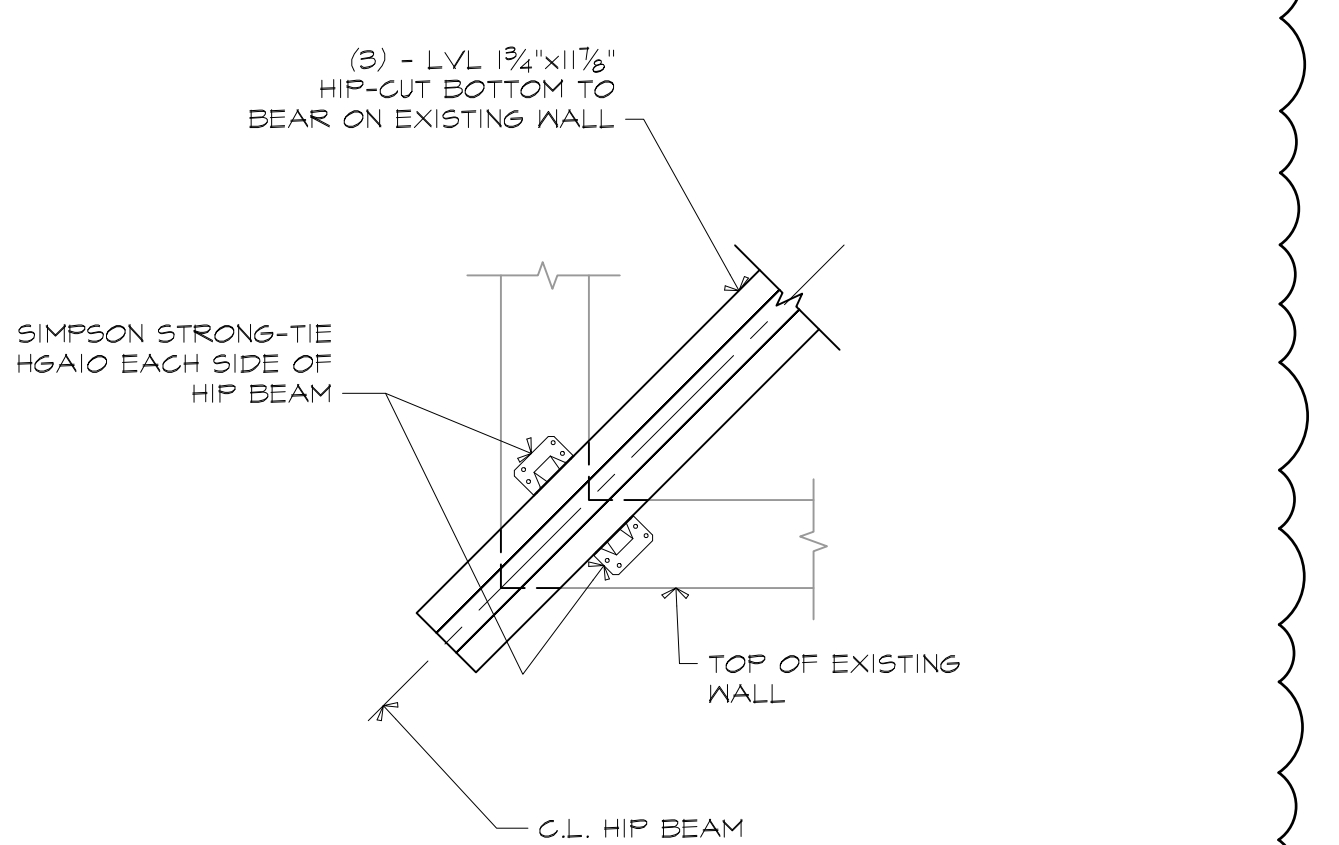

8 DETAIL 1"=1'-0"

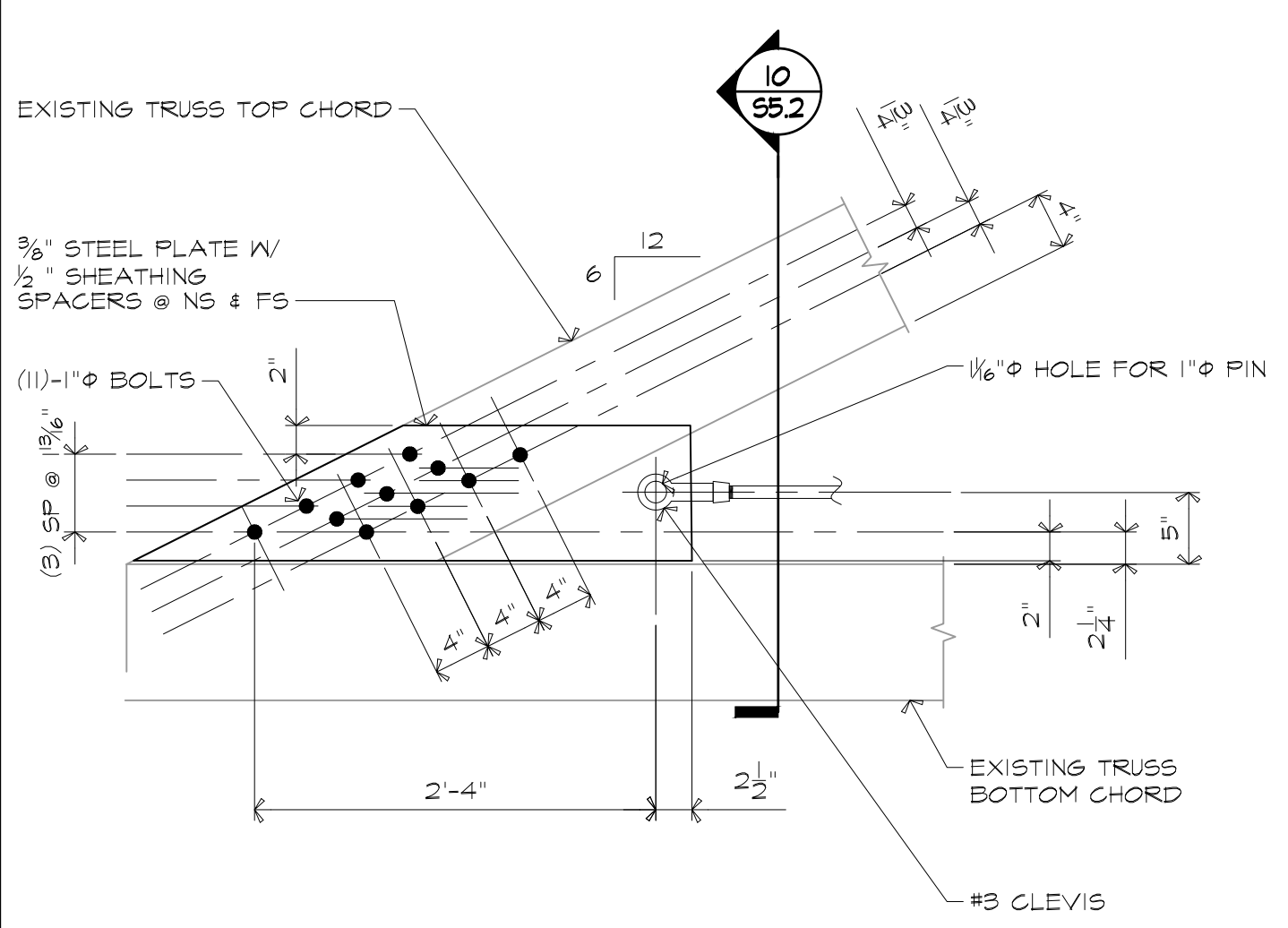

9 SECTION 1"=1'-0"

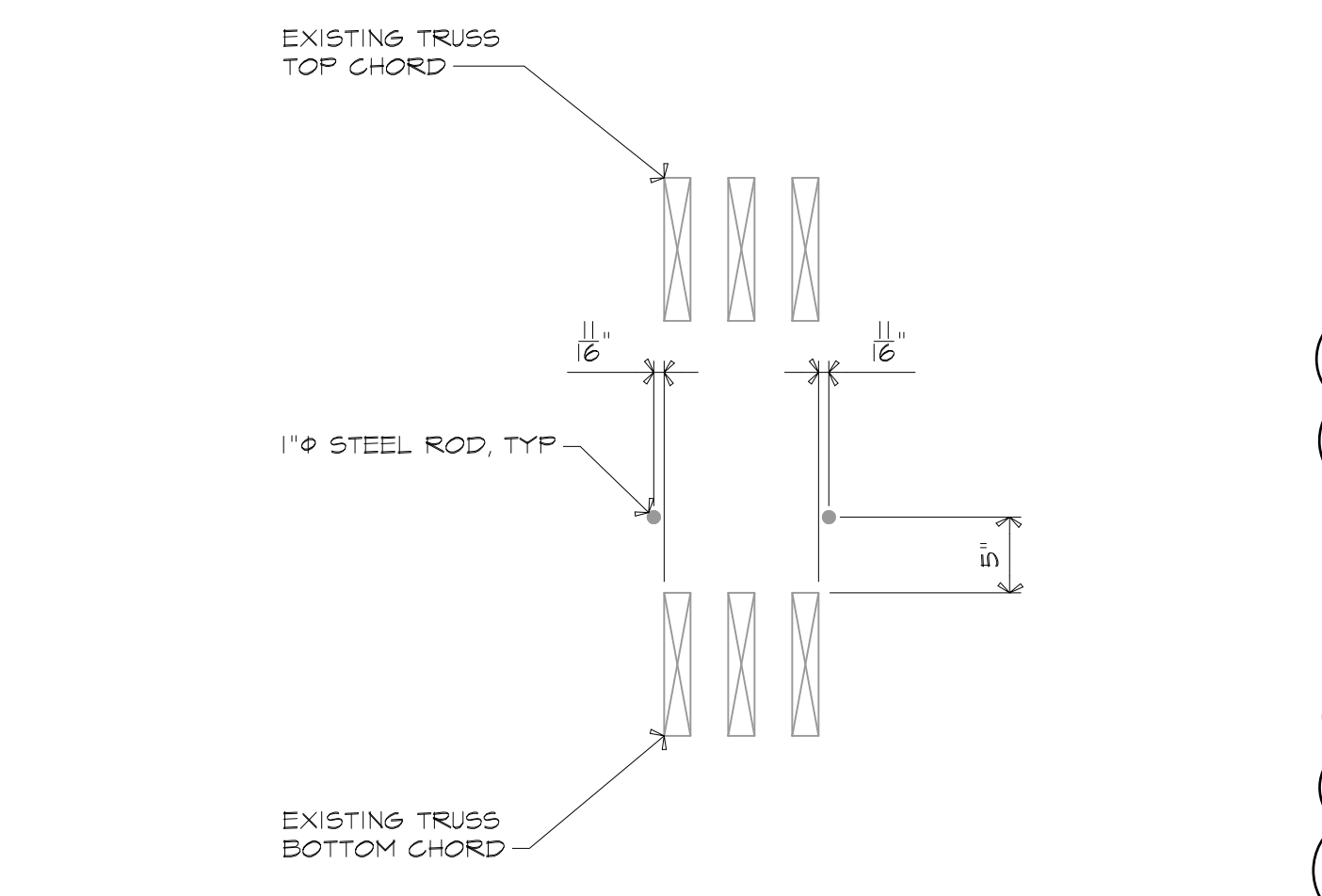

10 SECTION 1"=1'-0"

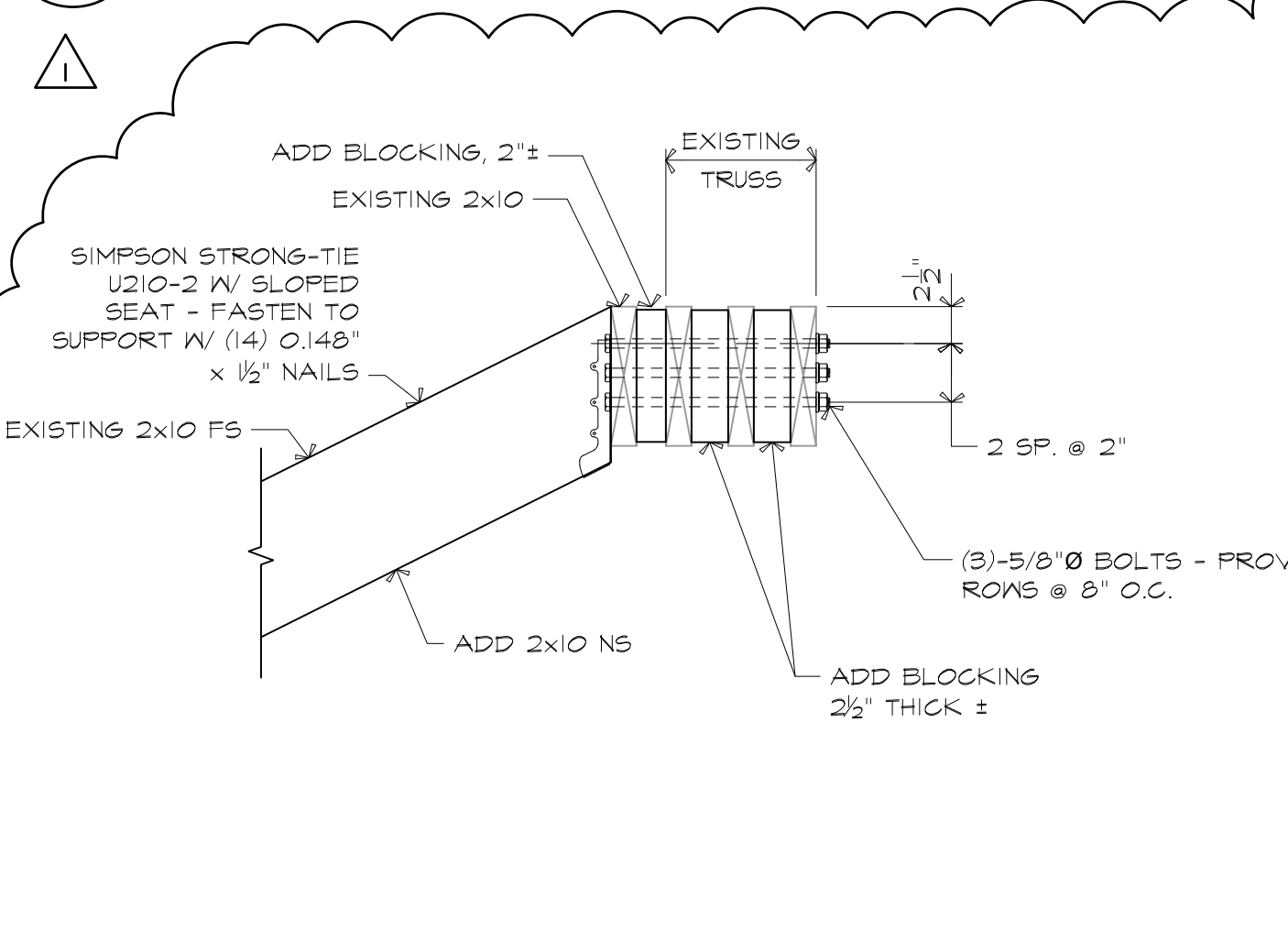

11 SECTION 1"=1'-0"

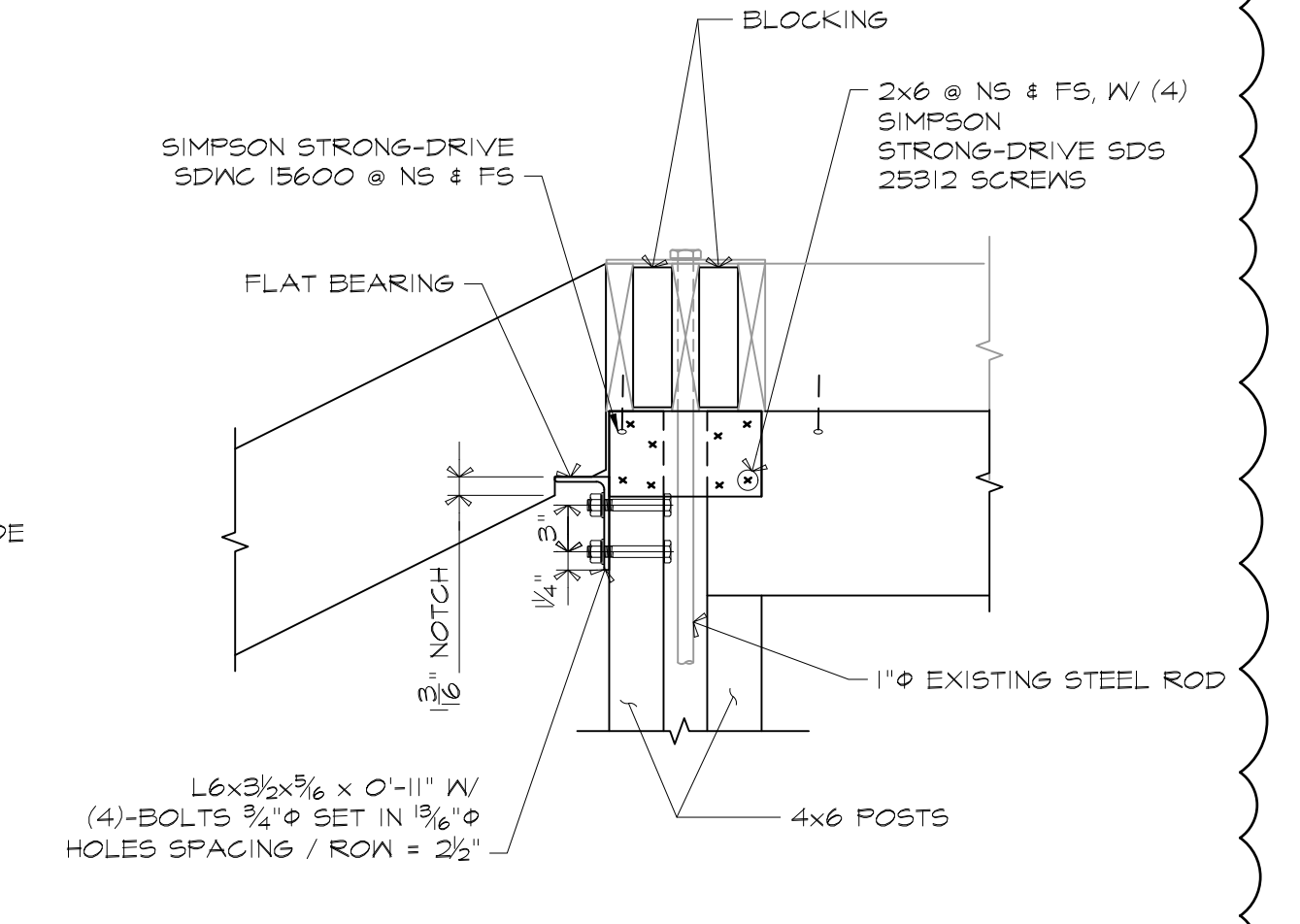

12 SECTION 1"=1'-0"

NO.	DATE	REVISION
1	6-1-23	APPENDUM No. 1

BOLDUC CORRECTONAL FACILITY
ADMIN BUILDING ROOF PLAN
WARREN, MAINE
 FRAMING SECTIONS & DETAILS

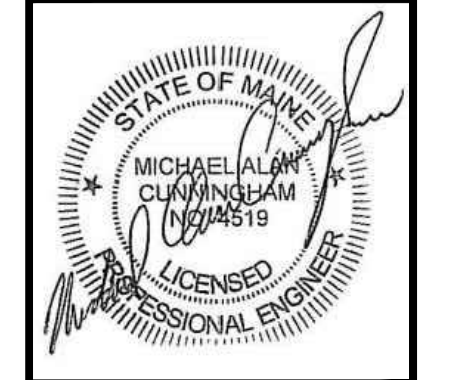

Lincoln / Haney
 Engineering Associates, Inc.
 14 Maine Street, Suite 306A
 Brunswick, Maine 04011
 Phone: 207-729-1061 Fax: 207-729-2941

S5.2

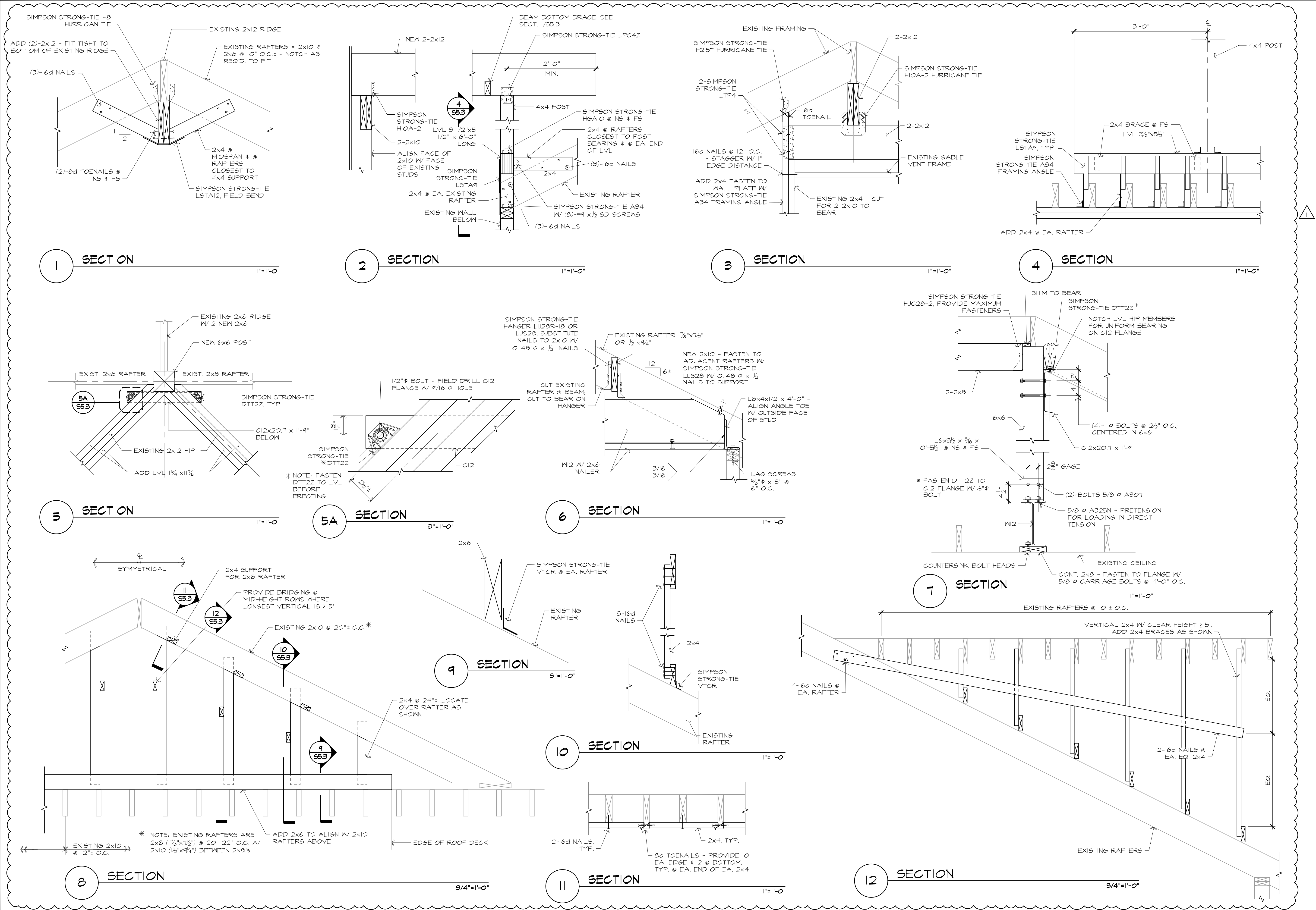

NO.		DATE		REVISION	
1		6-9-23		APPENDUM No. 1	

BOLDUC CORRECTIONAL FACILITY
ADMIN BUILDING ROOF PLAN
WARREN, MAINE

DRAWN BY	S/M	CHECKED BY	M/AC
ISSUE DATE	5-22-2023	PROJECT NO.	2022-053

FRAMING SECTIONS & DETAILS

Lincoln / Haney
 Engineering Associates, Inc.
 14 Maine Street, Suite 306A
 Brunswick, Maine 04011
 Phone: 207-729-1061 Fax: 207-729-2941

S5.3

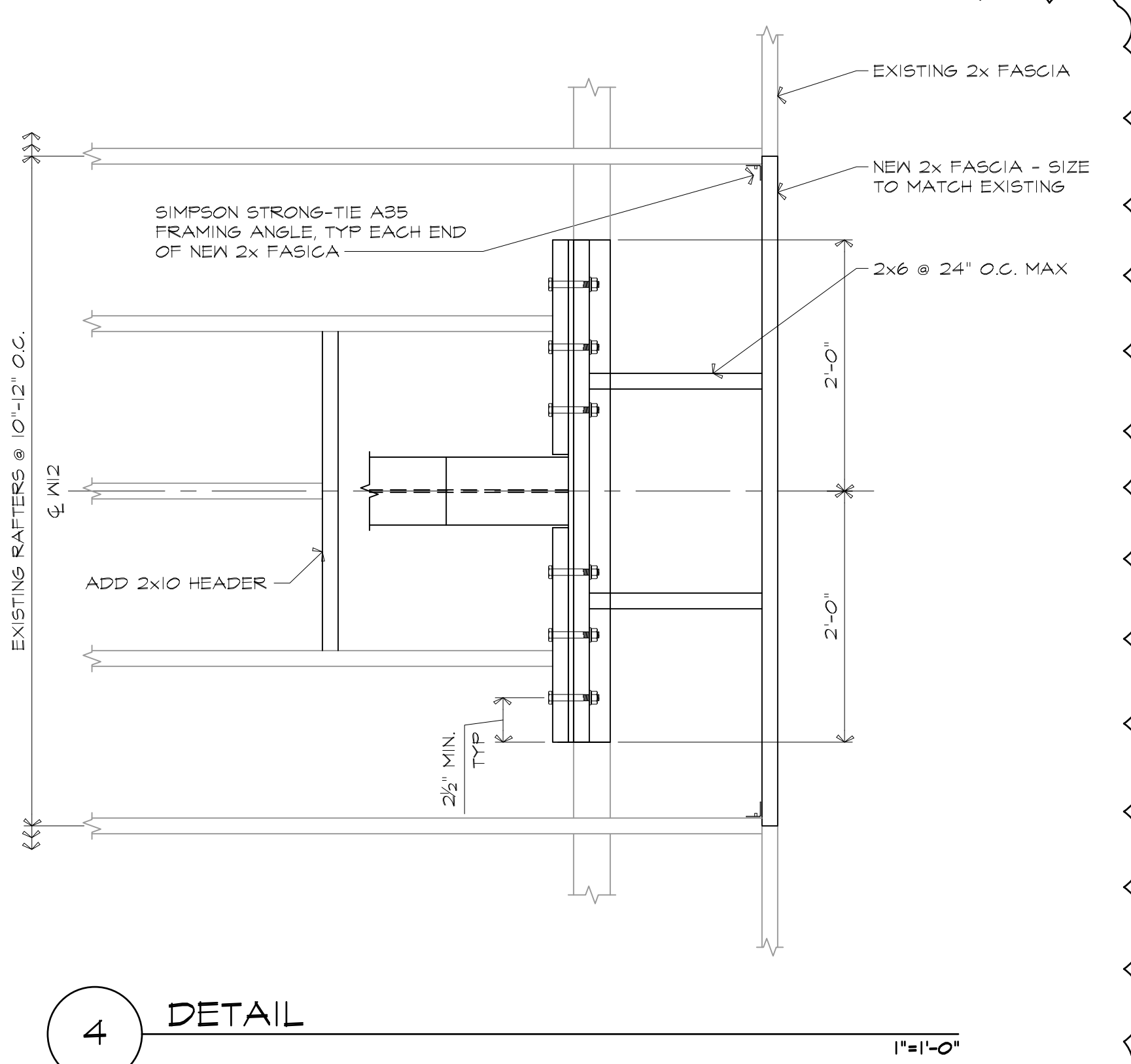
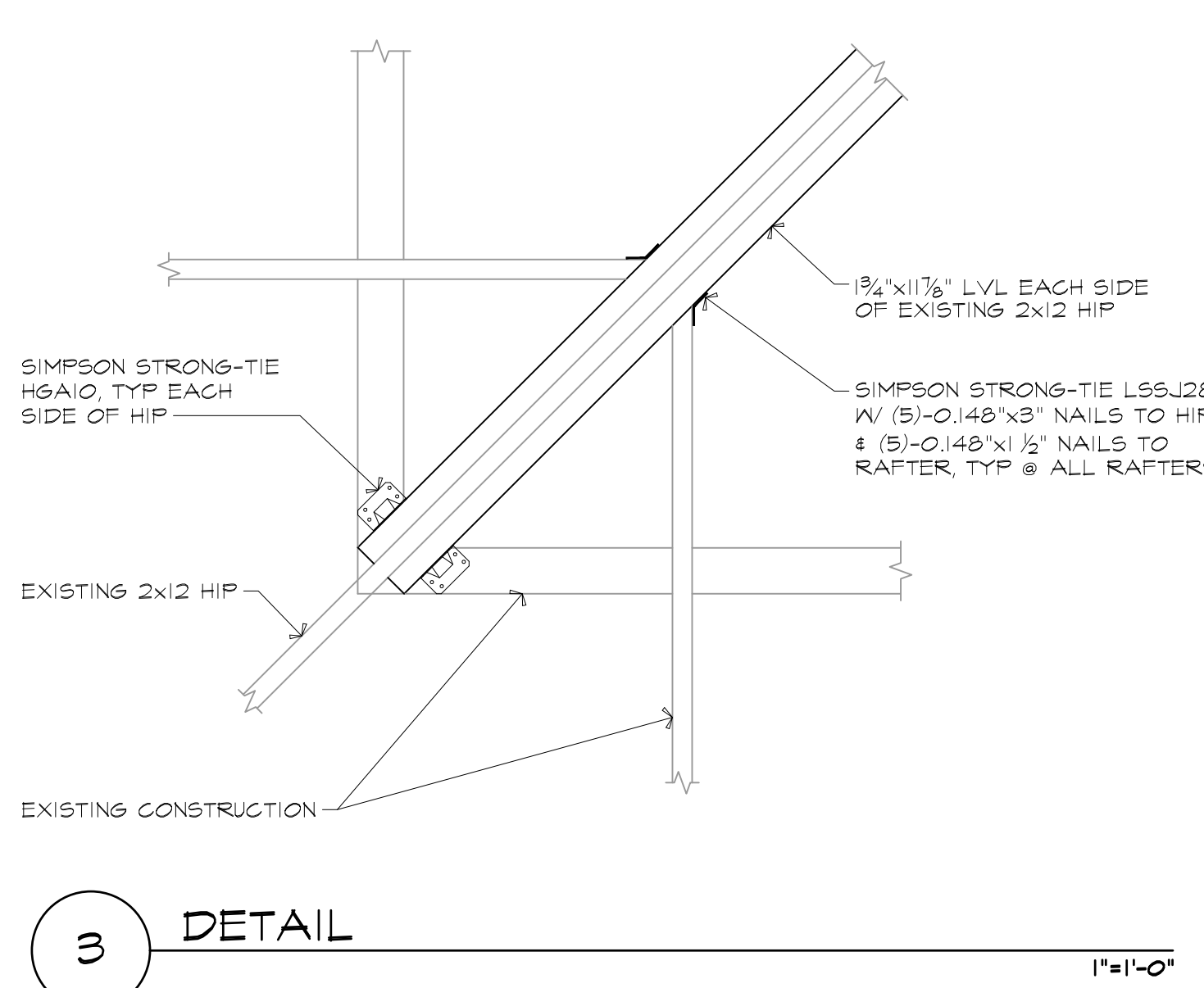
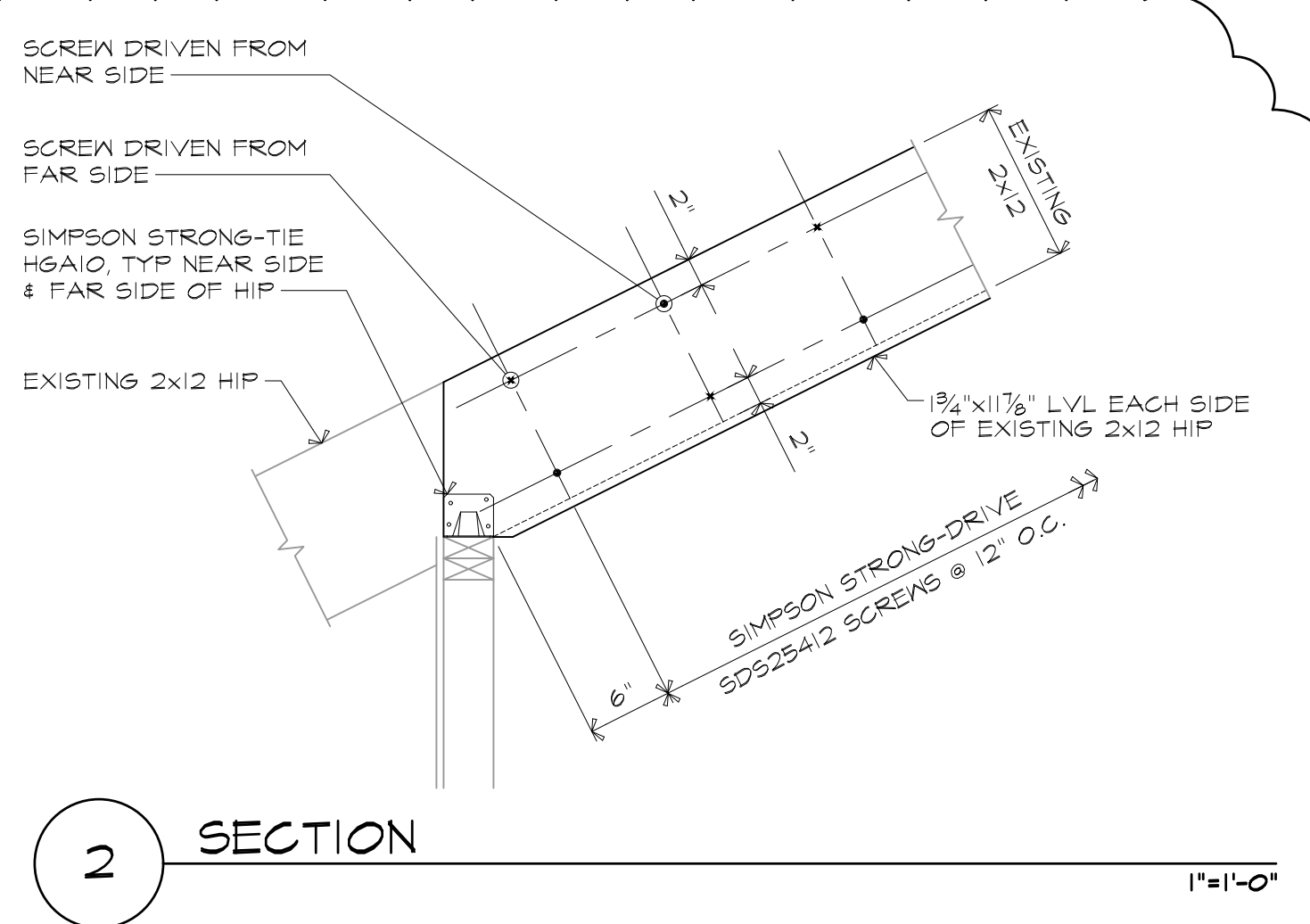
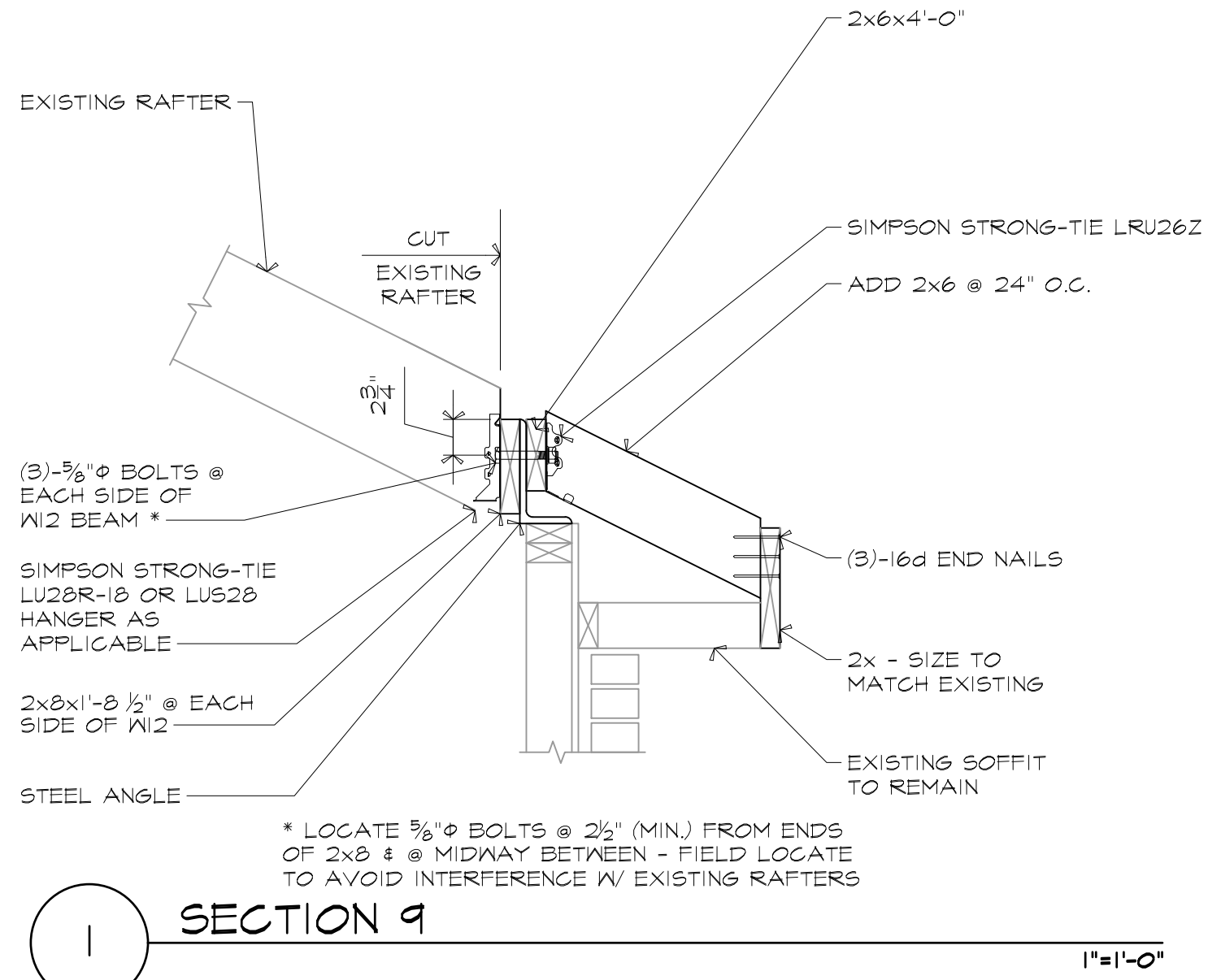

NO.	DATE	REVISION
1	5-XX-23	APPENDUM No. 1

BOLDUC CORRECTIONAL FACILITY
ADMIN BUILDING ROOF PLAN
WARREN, MAINE

FRAMING SECTIONS & DETAILS

DRAWN BY: SJAM
 CHECKED BY: MAC
 ISSUE DATE: 5-22-2023
 PROJ. NO.: 2022.053

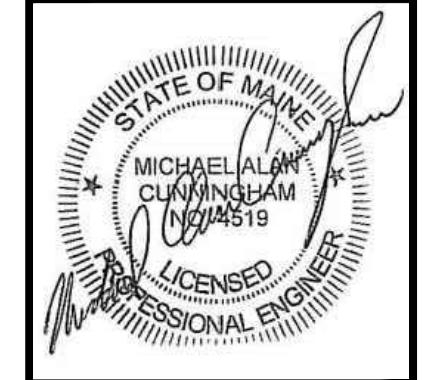

Lincoln / Haney
 Engineering Associates, Inc.
 14 Maine Street, Suite 306A
 Brunswick, Maine 04011
 Phone: 207-729-1061 Fax: 207-729-2941

S5.4