

ADDENDUM #1

This addendum modifies, amends, and supplements designated parts of the Contract Documents, Specifications, and Drawings for:

MEANG Building 541 Renovate for Boom Operator Simulation System - BGS Project # 3430

Bangor ANGB, Bangor, ME 04401

101st Civil Engineer Squadron

7 August 2023

It shall be the responsibility of the Contractor to notify all Subcontractors and Suppliers for various portions of the work of any changes or modifications contained in this Addendum.

Clarification Items: (Includes answers to questions submitted after the pre-bid conference)

1. **On Dwg. CP101, Utility Note #2 references Light Poles & Light Pole Bases. Please clarify if there are any light poles and bases required on this project.**
 - a. For the proposed project, there are no connections to any light poles or bases. This is a general note that WBRC carries on our project plans to ensure the electrical and site contractors are coordinating labor. (MG, WBRC)
2. **For the New Underground Utility Conduits between the proposed BOSS pad and Building 541. Can you provide a detail on how the conduits should penetrate Building 541. Core through the foundation wall and stub into the interior slab or 90 out of the ground through the concrete walkway and penetrate exterior wall with LB fittings.**
 - a. The underground conduits should penetrate west side of B541 electrical room by 90 sweeps out of the ground through the concrete walkway, up the side of the building to minimum height above MDP, then LB elbow into building. Inside into another LB elbow which then conduits inside the electrical room across one wall into 90 sweep around corner, then 90 down into top of the MDP. (TN, 101CES)
3. **For the New Underground Utility Conduit Trench please provide specifications and detail on concrete walkway patch against Building 541.**
 - a. Please see Attachment A. (CR, 101CES)
4. **Please clarify the location where the (2) 2-1/2" electrical conduits are to be stubbed up in or around the proposed concrete slab.**
 - a. Install on plan south end of HVAC slab. (TN, 101CES)
5. **During our Pre-Bid site walk, it was discussed that electrical and possibly telecommunications scope will be added to the project. Please confirm these requirements and provide electrical & tel-com drawings and specifications. a. Conductor Requirements b. RSS Utility Pedestal detail and specifications c. Interior Building 541 electrical requirements d. Etc.**
 - a. Section 3.1 of the Statement of Work (included on pg. 60/63 of 00 project specifications) addresses utility requirements of the contract, including - "The Contractor shall install all wire in conduit per project drawings, specifications, and attachments." Attachment B includes all electrical requirements.
 - a. **Conductor Requirements**
 - a. The communications conduit only requires installation of pull-wire for later installation of communications lines by the 101st Communications Flight.

Electrical conductor requirements are found in RSS Utility Preparation, sec 7.1.2/3. “Provide disconnect and cable sized to power the RSS with 120/208V, 200 Amp panel... Ensure the PVC extends up past the slab by 2 feet and has a freestanding weatherproof disconnect... The installed simulator will require the same power setup as the RSS to provide 200 amp service to the “simulator power and communications input/output panel”... When installed, the RSS will have two 200 amp services which includes two 200 amp umbilicals, one for dedicated RSS power and the other for dedicated simulator power.” (TN, 101CES)

b. RSS Utility Pedestal detail and specifications

b. Ensure PVC extends past slab by 2’ w/ freestanding weatherproof disconnect, in accordance with latest version of the NEC. Install on plan south end of HVAC slab. (TN, 101CES)

c. Interior Building 541 electrical requirements.

c. Please see RFI #2 response. (TN, 101CES)

6. It is mentioned several times on the drawings and specification that the relocation and placement of the RSS Building and BOSS Building are to be completed by the contractor. During the Pre-Bid site walk, we learned that these are no longer required. Please confirm.

a. 00 11 13 Notice to Contractors – *“Sitework, utilities, and installation of foundation to support Boom Operator Simulation System (BOSS) and Relocatable Shelter System (RSS). Construction of approximately 1,500 sf slab-on-grade foundation. Trenching for and installation of conduit for electrical connection from RSS to adjacent building (B541).”*

b. Installation of the RSS and BOSS are not included in this contract. All references to installation of these in the provided project documents are For Reference ONLY.

7. Bearing plates and post-installed anchors for the RSS Building shown on dwg. S-100, Detail H10. Please confirm that these are to be supplied by the contractor. Please provide manufacturer’s contact information.

a. To be installed by contractor.

b. Sea Box North America, Corporate Office:

1 SEA BOX Drive

East Riverton, NJ 08077-2022

Phone: 856-303-1101

Fax: 856-303-1501

Email: sales@seabox.com

8. Can we be provided with a basis of design/representation of building placement on the proposed slab and foundation walls.

a. The basis of design for the proposed slab and foundation walls is based on the RSS 4-Pack building by Sea Box. (MG, WBRC). Please see Attachment C. (TF, 101CES)

- 9. Is it acceptable to shutdown the driveway from the runway and plan west to excavate trench in one phase? Does the contractor need to ensure access to any part of the rear of building 541. We heard a few concerns about access during the Pre-Bid conference.**
- a. Yes, it is acceptable to shutdown the referenced driveway. The 101st will request a phasing plan from the contractor that will include dates when the West driveway will be shutdown. B541 occupants will require access to the plan East driveway and associated overhead door. (TF, 101CES)
- 10. On Dwg. C501, Detail N10 shows a foundation wall and footing running along the plan west side of the concrete pad. The foundation/slab plans on Dwg. S-100 does not show a foundation wall or footing on the plan East or West sides of the slab. Please clarify if a foundation wall and footing is required on the plan East or West sides of the slab.**
- a. The foundation wall and footing are not designed on the plan east or plan west sides of the slab as they are not needed. (MG, WBRC)
- 11. On Dwg. S-100, there is not a foundation or footing on the plan East or West of the slab. Does there need to be any frost protection or slab haunch in these areas to prevent water infiltration?**
- a. Frost protection as designed is appropriate for this project. (MG, WBRC)
- 12. On Dwg. C501, Detail N10 shows the roof drain strips without an elevation on the 4" SCH 20 perforated drainpipe. When reviewing Dwg. CP101, it shows the top of drainpipe shall be at 188.50 elevation. Please confirm this elevation for the length of pipe.**
- a. Design intent is to provide the underdrain at the lowest elevation possible that will achieve a positive outlet within the limit of work. Based on available information:
 - i. The perforated drain shall be installed with an invert at 188.50.
 - ii. All drainage with less than 4' of cover shall be protected with 4' of rigid insulation.
 - iii. Prior to construction commencing, contractor shall confirm elevations at existing pavement, and elevation of low point to plan south where New Grass Swale outlets.
- 13. Please provide the hot mix asphalt depths for patching the existing driveway after trenching.**
- a. Trench pavement shall me the requirements of Detail J14, Sheet C-501.
- 14. In specification section 31 20 00, 3.19, Part B.1 they refer to subdrainage geotextile under subbase on subgrade under concrete slab but in details on Dwg. S-100 Detail# D10 and Dwg. C501, Detail# A10 it does not call for it. Please clarify requirements.**
- a. Delete section 3.19 from Specification 31 20 00.
- 15. I Builder Risk Insurance required for this project?**
- a. Per 00 72 13, 9.3.4- Builder Risk Insurance is required.
- 16. Is ECM (Erosion Control Mulch) acceptable for silt fencing?**
- a. Erosion Control Mix Berm is an acceptable alternative to Silt Fence, if installed in accordance with the Maine Erosion and Sediment Control Pactices Field Guide for Contractors as published by the Maine DEP, most recent revision. All erosion and sedimentation control documents referencing Silt Fence shall apply to Erosion Control Mix Berm. Care shall be taken by the contractor to mitigate all foreign object debris/damage (FOD). FOD mitigation is paramount for all work accomplished within the airfield perimeter.

Specification Items:

1. Replace Specification 00 41 13 (updated IFB documents date).
2. Delete section 3.19 from Specification 31 20 00 (reference RFI #14).

Attachments:

- A. Concrete Sidewalk Detail & Notes
- B. RSS Utility Preparation Requirements
- C. SEA BOX RSS Cut Sheet
- D. Specification 00 41 13 Contractor Bid Form (updated)

ATTACHMENT A

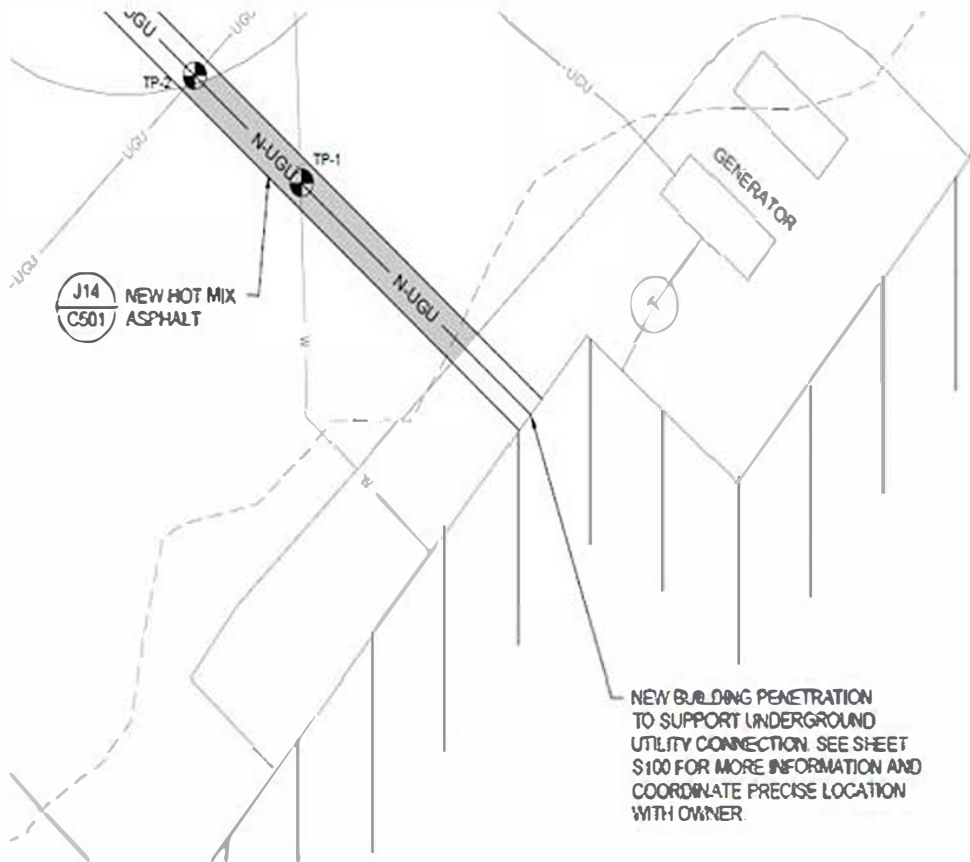

UTILITY NOTES:

1. SEE UTILITY NOTES ON SHEET C001 FOR ADDITIONAL INFORMATION.
2. EXISTING CONCRETE WILL REQUIRE SAW CUT LARGE ENOUGH TO ACCESS UTILITES, UTILITY INFORMATION SPECIFIED ON SHEET C001, N14.

GRADING NOTES:

1. THE EXISTING CONCRETE HAS A DEPTH OF 6" THAT WILL REQUIRE REMOVAL .
2. FOR APPROPRIATE RESTORATION SAW CUT CONCRETE SECTION WILL NEED TO BE JACKED, DISPOSED OF AND RE POURED.
3. IF CONCRETE IS CUT ON EXPANSION JOINT, REPLACE JOINT, SEE CONCRETE DETAIL BELOW
4. MATCH 6"X6" EXISTING WIRE MESH OF EXISTING CONCRETE, SEE DETAIL BELOW

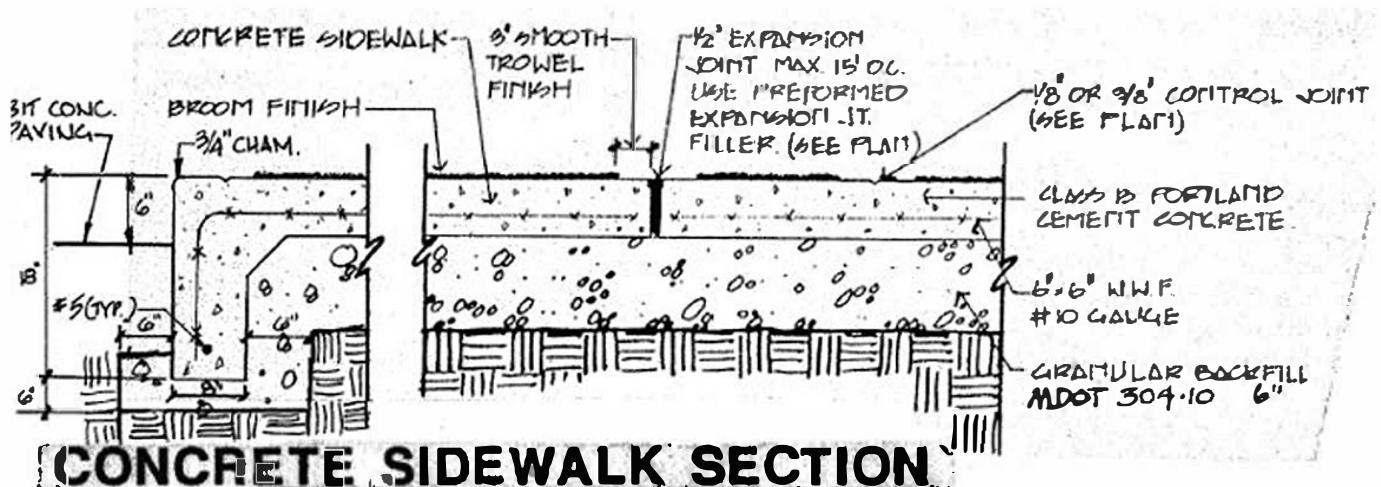

ATTACHMENT B

6.4 Utility Area

The Manufacturer drawings in “9. Appendix A — Minimum Concrete Specifications” highlights a suggested utility area where conduits, power racks, meter socks, and other associated equipment should be terminated. This area will allow for ease of connectivity to the RSS input/output panel and will provide sufficient space for the installation of the RSS.

The suggested utility area, regardless of RSS size, is 1 ft, 6 in by 6 ft, 6 in and should be located 21 ft, 8¼ in from the edge of the concrete slab and 2 ft, 9¼ in from the top of the first grade beam. See the second drawing for every size of RSS in Section “9. Appendix A — Minimum Concrete Specifications” for additional measurements and specifications.

7. UTILITIES AND COMMUNICATIONS

The RSS will include a communications panel which will allow data lines to be transferred through the RSS from exterior to interior. Data/fiber lines do not come standard with the RSS and will have to be installed by the unit ahead of the RSS installation.

Ahead of the RSS installation, bring all data/fiber lines to the exterior I/O panel. Data/fiber lines include SIPR/NIPR, internet, network, phone, and other necessary line items. After the RSS installation, bring all data/fiber lines through the I/O panel and into the RSS.

For ANG projects, ANG will provide funding for utilities to be run within 5 ft of the proposed installation area. However, ahead of the RSS installation, the gaining unit will be responsible for all required work and associated costs to continue the run of utilities and other lines to the identified site. When selecting a site for installation, consider the distance that all lines will have to travel and the associated cost for each. See Section “8. Security” for additional information regarding utility requirements.

7.1 Electrical

This section provides an overview and drawings of the electrical features found on the RSS. The electrical system of the RSS meets the requirements of the NFPA standard 70E and follows the guidance provided in all applicable section. See Section “10. Appendix B — RSS electrical drawings” for more information.

7.1.1 Main Power Cord

The main power cord supplies all power to the RSS and connects via an exterior I/O panel. While the Manufacturer will provide the main power cord, the gaining unit is responsible for connecting the main power cord to the site transformer/disconnect/circuit panel.

The provided main power cord meets the following characteristics and specifications:

- 50 ft long
- Four 4/0 AWG conductors
- Four #4 AWG grounds
- Nominal Outside Diameter: 2.145 in
- Pin and sleeve connector (UEC PN#MS90557C52412S)

- Pig tail leads for unit connectivity to transformer/disconnect/circuit panel
- Type G (OMNI PN#B64/004)
- Insulated and designed to lie on the ground

If the main power connector will be buried, consider using strain relief (Hubbell PN#074011037 or Hubbell PN#SHC1089) to ensure a watertight seal and positive contact.

7.1.2 Required RSS Power

The RSS requires shore power of 75 KVA (120/208 V, 200 Amp, 3 phase) to power the RSS power input/output panel. The RSS can also temporarily connect to generator power with the same specifications.

Provide disconnect and cable sized to power the RSS with 120/208V, 200 Amp panel. Provide the hardware needed to make all the connections. From the disconnect, run one 4 inch PVC electrical duct. Ensure the PVC extends up past the slab by 2 feet and has a freestanding weatherproof disconnect. Run cable size for 200 Amp panel from disconnect to the slab disconnect. Perform all electrical work in accordance with the latest and greatest version of the National Electric Code (NEC) and in accordance with local and state statues as well as the base approved electrical drawings.

Upon RSS installation, connect the main power cord to the site transformer, disconnect, or circuit panel.

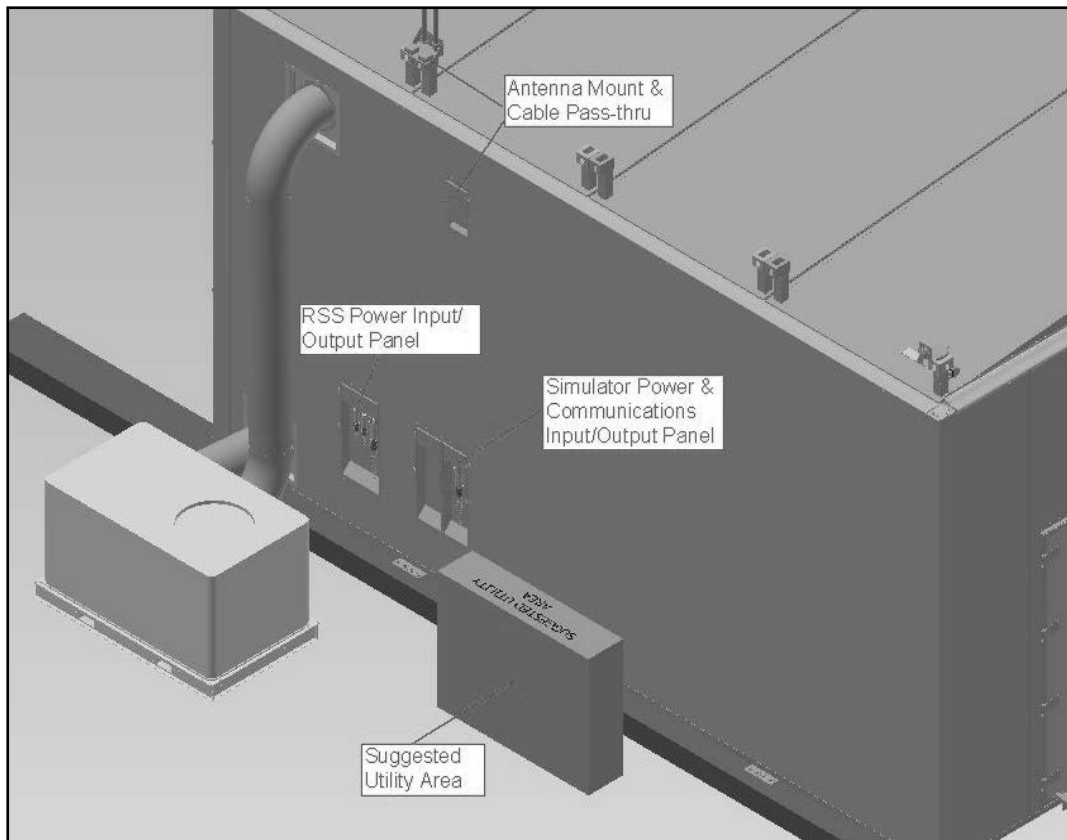
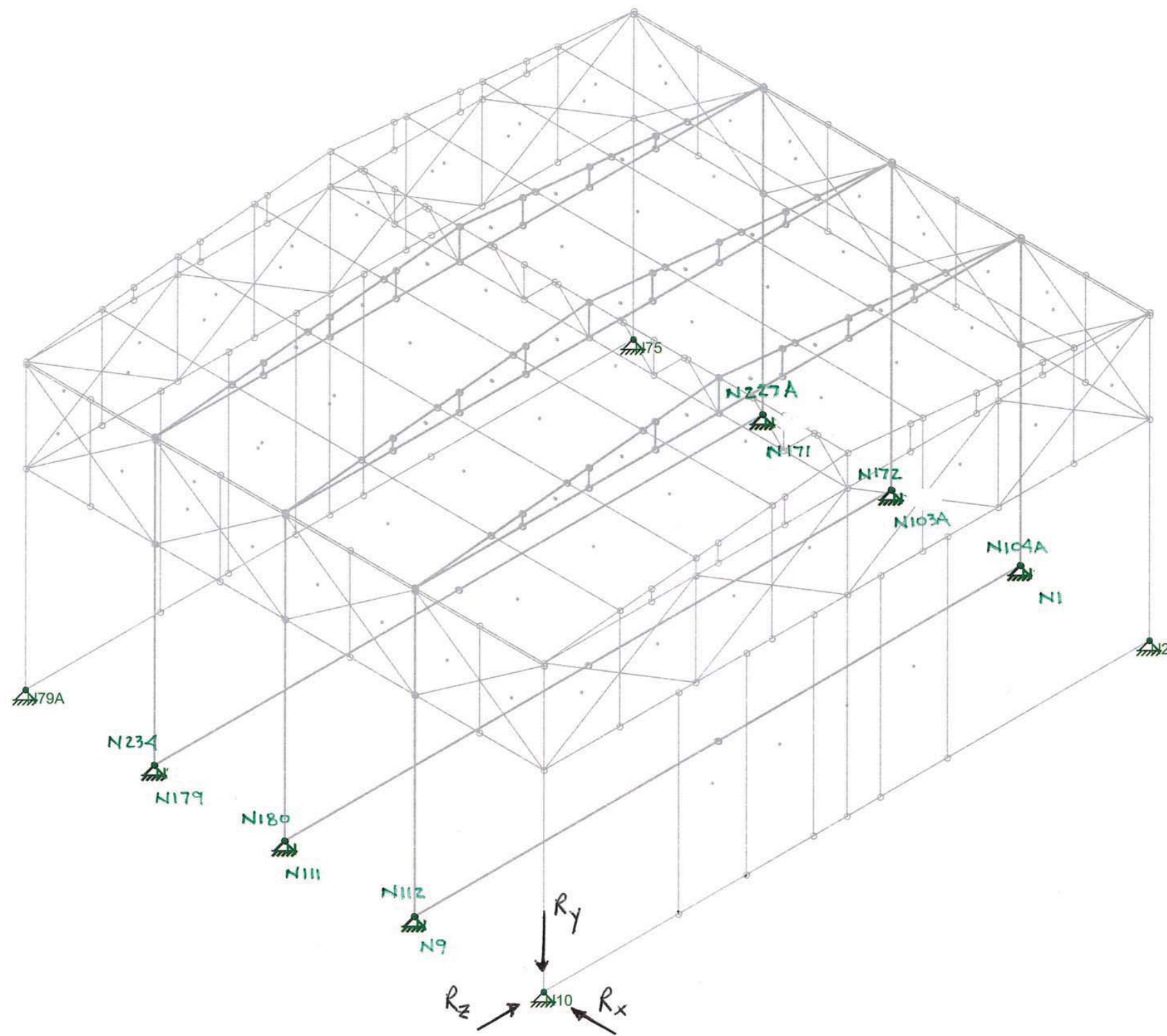
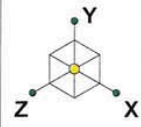

Figure 2: RSS Power Panel and ECU Locations



Envelope Only Solution

PMH Associates

TKR

15343

Seabox Simulator

SK - 1

May 11, 2016 at 11:54 AM

15343 100MPH80SNOW w actual floor beam + 50 ksi cols and side girts + live...

10. APPENDIX B — RSS ELECTRICAL DRAWINGS

10.1 RSS Electrical Schematic

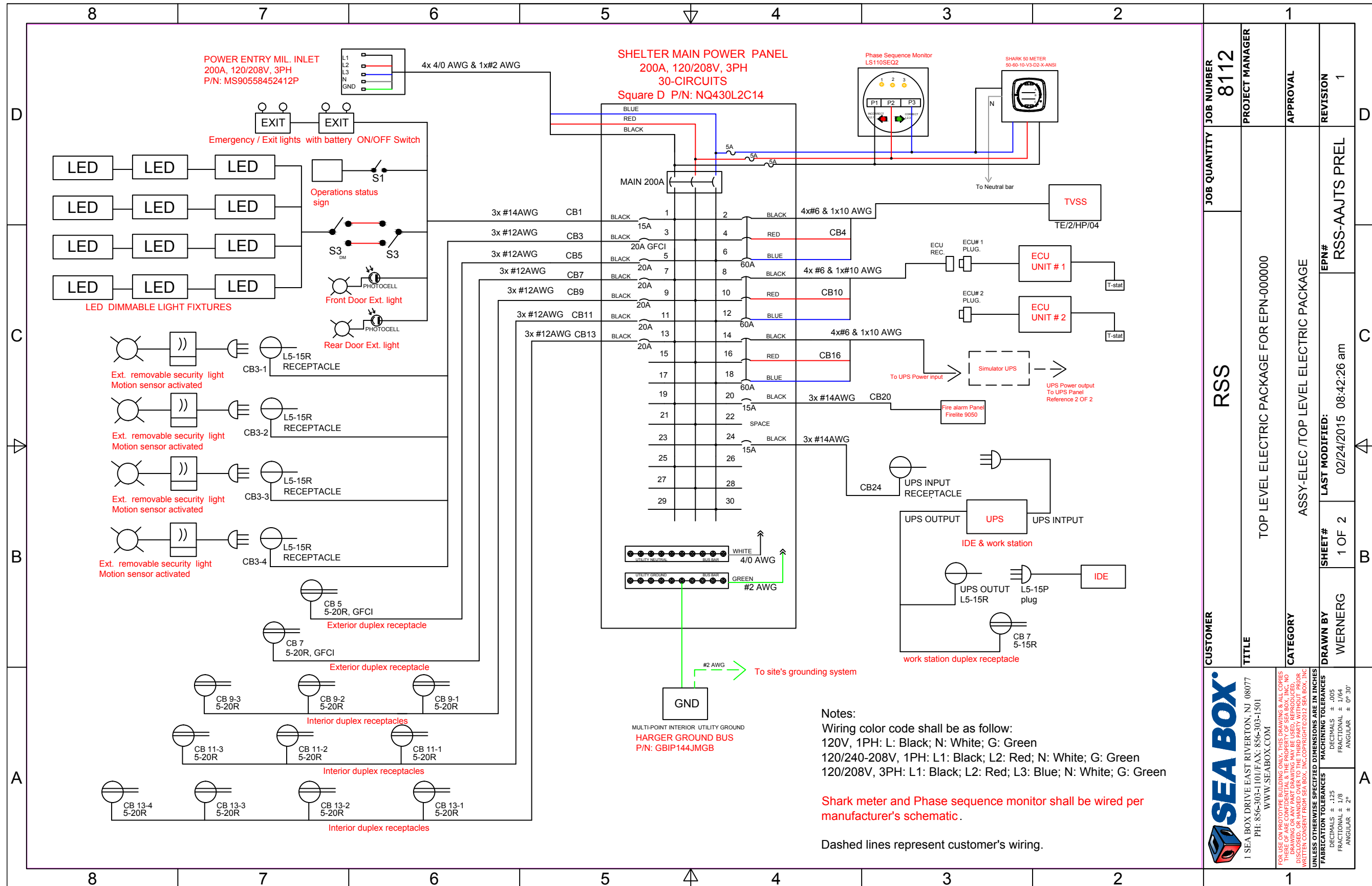

10.2 RSS Interior Electrical Connections

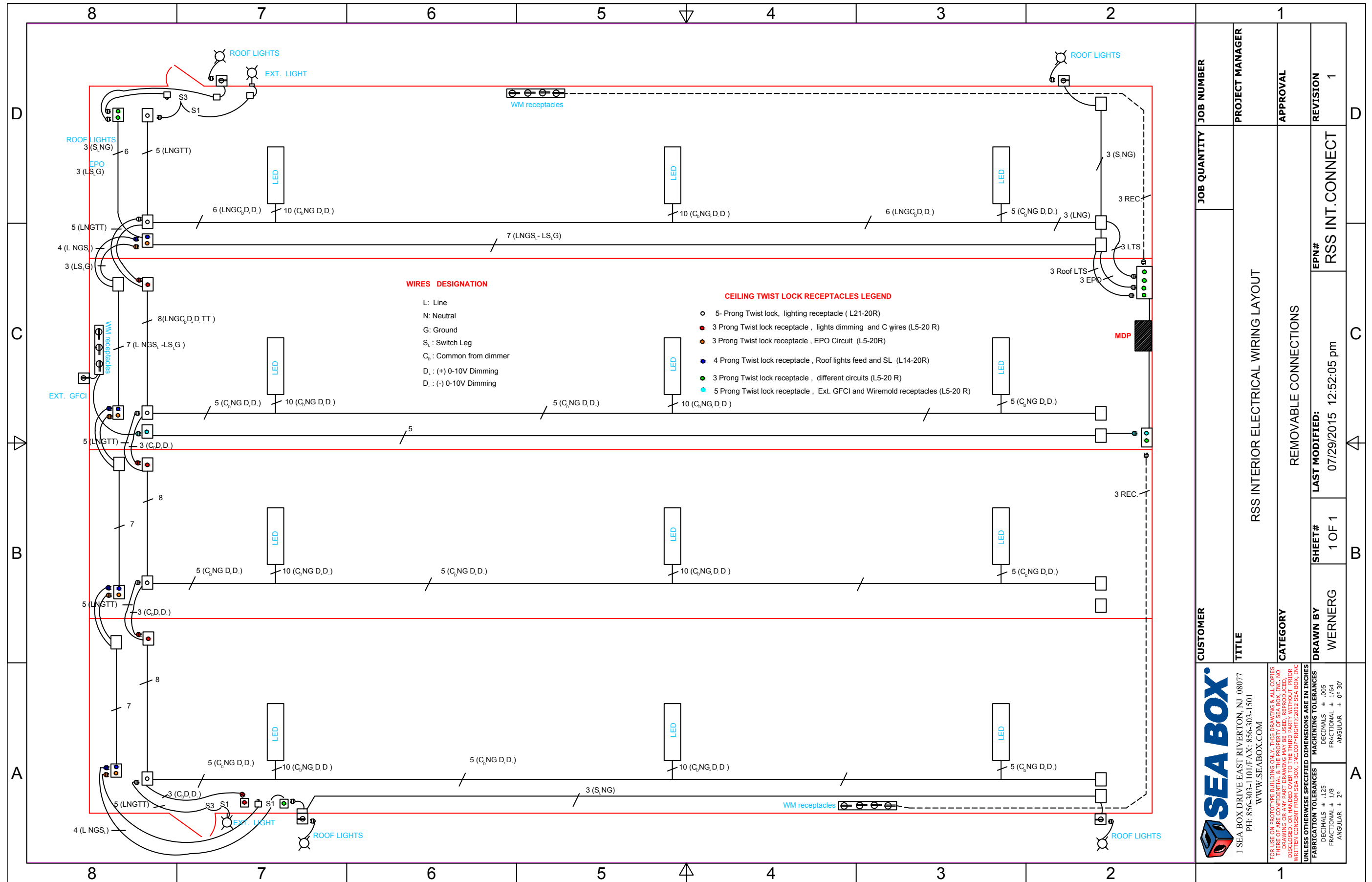

SEA BOX
 1 SEA BOX DRIVE EAST RIVERTON, NJ 08077
 PH: 856-303-1101/FAX: 856-303-1501
 WWW.SEA BOX.COM

FOR USE ON PROTOTYPE BUILDING ONLY. THIS DRAWING & ALL COPIES THEREOF ARE THE PROPERTY OF SEA BOX, INC. NO PART OF THIS DRAWING OR ANY PART DRAWING MAY BE USED, REPRODUCED, DISCLOSED, OR HANDED OVER TO THE THIRD PARTY WITHOUT PRIOR WRITTEN CONSENT FROM SEA BOX, INC. COPYRIGHT © 2012 SEA BOX, INC. UNLESS OTHERWISE SPECIFIED DIMENSIONS ARE IN INCHES

FABRICATION TOLERANCES	MACHINING TOLERANCES
DECIMALS ± .125	DECIMALS ± .005
FRACTIONAL ± 1/8	FRACTIONAL ± 1/64
ANGULAR ± 2°	ANGULAR ± 0° 30'

CUSTOMER
 TITLE
 CATEGORY
DRAWN BY
 WERNERG

JOB QUANTITY
 RSS INTERIOR ELECTRICAL WIRING LAYOUT
REMOVABLE CONNECTIONS
LAST MODIFIED:
 07/29/2015 12:52:05 pm
SHEET#
 1 OF 1
EPN#
 RSS INT.CONNECT
REVISION
 1

JOB NUMBER
PROJECT MANAGER
APPROVAL
REVISION

ATTACHMENT C



SEA BOX[®]

Relocatable Simulation Shelter (RSS)

Sea Box's Relocatable Simulation Shelter (RSS) provides a durable, reliable and efficient shelter to support simulator operations.

Ease of Setup

The shelter frames have a Patented collapsible design which simplifies set up. The end frames remain attached to the floor and roof of the shelter during transport. When the roof is lifted during deployment, the end frames slide into place creating a solid structure. Wall panels are then positioned in channels around the perimeter and are bolted into place.

Fully Redeployable

The key feature of our RSS is its ease of disassembly, pack out and transport for redeployment. Sea Box's RSS can be disassembled and fully packed out on two flatbed trailers for domestic transport or into three 40' high cube ISO containers for overseas shipment.

Base Model Key Features

- Shelter can be fully erected in a matter of days on slab or footings.
- Walls, and ceiling panels consist of a galvanized steel exterior and perforated steel interior with a core made of non-combustible structural mineral wool for superior insulation and noise absorption.
- Wall panel design is water resistant and durable for relocation, pack up and shipping.
- Shelter comes equipped with one 7.5-ton ECU
- R value of 21.
- Electrical system includes wiring for power monitors, phase sequencing, utility power and a trainer power plug.
- Fire, smoke, and heat detection system in accordance with NFPA regulations.
- Conforms to Security Standards in DoDM 5200.01-V3
- Custom sizes available to accommodate equipment
- Removable access panel (72 1/8" W x 84 1/4" W) and ramp for equipment loading and unloading.
- Anti-static carpet throughout

Priced at a fraction of the cost of permanent structures.

Contact Sea Box today for additional information or to discuss customized features for your shelter needs!



Interior
Flat Black



Exterior
33446 Desert Tan

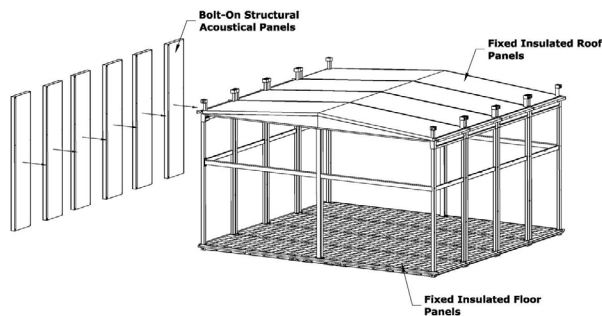

U.S. Patent No.
9,108,758

NSN #: 6920-01-647-6162

	LENGTH		HEIGHT			WIDTH*			Volume
	Exterior	Interior	Exterior w/ Roof Lights	Exterior	Interior	Exterior w/ HVAC	Exterior	Interior	
Ft in	34' - 1"	32' - 3"	19' - 7"	18' - 7"	16' - 0"	41' - 7"	31' - 4"	29' - 1/4"	15,093 Cu. Ft.
Metric	10,372	9,830	5,968	5,663	4,877	12,674	9,549	8,915	427 Cu. M.

* RSS width can be extended indefinitely in increments of 91" (2,311mm)

SB3897-RSS-4S
 Relocatable Simulation Shelter (RSS)

041916-R00

ISO 9001:2008



CERTIFIED QUALITY
MANAGEMENT SYSTEM



Relocatable Simulation Shelter (RSS)

Sea Box's Relocatable Simulation Shelter (RSS) provides a durable, reliable and efficient shelter to support simulator operations.

Additional Features

- Wind load rating of 200 mph.
- Snow load rating of 80 psf.
- Anti-static flooring.
- FFL 2740 approved X10 spin dial lock on main door.
- Secondary push button cypher lock.
- Two-way video intercom system at main door.
- Provisions provided for external mounted C.A.C. reader and intrusion detection system with U.P.S.
- Four exterior roof mounted flood lights.

Plug and Play Electric System

- 200A, 3-phase, 50/60 Hz electrical I/O panel.
- Communication panel with 7 RJ-45 waterproof connections.
- Power/Voltage/Amperage meter.
- Emergency power off buttons.
- Phase sequence monitor.
- Dimmable LED interior lighting
- Simulator operator UPS

Optional Features

- Tricon Vestibule
- Interior structure to create second floor / mezzanine and office space
- Additional sizes



U.S. Patent No.
9,108,758

NSN #: 6920-01-647-6162

SB3897-RSS
Relocatable Simulation Shelter (RSS)

021016-R00

ISO 9001:2008



CERTIFIED QUALITY
MANAGEMENT SYSTEM

* RSS width can be extended indefinitely in increments of 91" (2,311mm)

ATTACHMENT D

**00 41 13
Contractor Bid Form**

MEANG Renovate Building 541 for Boom Operator Simulation System

3430

Bid Form submitted by: *email only to email address below*

Bid Administrator:

Mr. David Schoenherr
Bureau of General Services
111 Sewall Street, Cross State Office Building, 4th Floor
77 State House Station
Augusta, Maine 04333-0077

BGS.Architect@Maine.gov

Bidder:

Signature: _____

Printed name and title: _____

Company name: _____

Mailing address: _____

City, state, zip code: _____

Phone number: _____

Email address: _____

State of incorporation, if a corporation: _____

List of all partners, if a partnership: _____

The Bidder agrees, if the Owner offers to award the contract, to provide any and all bonds and certificates of insurance, as well as Schedule of Values, Project Schedule, and List of Subcontractors and Suppliers if required by the Owner, and to sign the designated Construction Contract within twelve calendar days after the date of notification of such acceptance, except if the twelfth day falls on a State of Maine government holiday or other closure day, or a Saturday, or a Sunday, in which case the aforementioned documents must be received before 12:00 noon on the first available business day following the holiday, other closure day, Saturday, or Sunday.

As a guarantee thereof, the Bidder submits, together with this bid, a bid bond or other acceptable instrument as and if required by the Bid Documents.

00 41 13
Contractor Bid Form

1. The Bidder, having carefully examined the MEANG Renovate B541 for Boom Operator Simulation System Project Manual dated 21 JULY 2023, prepared by WBRC, as well as Specifications, Drawings, and any Addenda, the form of contract, and the premises and conditions relating to the work, proposes to furnish all labor, equipment and materials necessary for and reasonably incidental to the construction and completion of this project for the **Base Bid** amount of:

\$ _____ .00

2. Allowances *are included* on this project.
Bid amount above includes the following Allowances
MATERIALS TESTING

\$8,500 .00

3. Alternate Bids *are not included* on this project.

<Bid Administrator to select...>

Any dollar amount line below that is left blank by the Bidder shall be read as a bid of **\$0.00**.

1 *insert title of Alternate or "not used"* \$ _____ .00

2 *insert title of Alternate or "not used"* \$ _____ .00

3 *insert title of Alternate or "not used"* \$ _____ .00

4 *insert title of Alternate or "not used"* \$ _____ .00

4. Bid security *is required* on this project.
If noted above as required, or if the Base Bid amount exceeds \$125,000.00, the Bidder shall include with this bid form a satisfactory Bid Bond (section 00 43 13) or a certified or cashier's check for 5% of the bid amount with this completed bid form submitted to the Owner.

5. Filed Sub-bids *are not required* on this project.
If noted above as required, the Bidder shall include with this bid form a list of each Filed Sub-bidder selected by the Bidder on the form provided (section 00 41 13F).