

**MAINE BUREAU OF PARKS AND
LANDS**

PROJECT MANUAL

For

**Mooring and Float Upgrades
Eagle Island State Historic Site**

Harpswell, Maine

BGS Project: 3481

Issued for Bid

December 28, 2023

PROJECT MANUAL

For

Mooring and Float Upgrades Eagle Island State Historic Site Harpwell, Maine

BGS Project: 3481

Prepared for:

**MAINE DEPARTMENT OF AGRICULTURE, CONSERVATION AND
FORESTRY**

BUREAU OF PARKS AND LANDS

Prepared by:

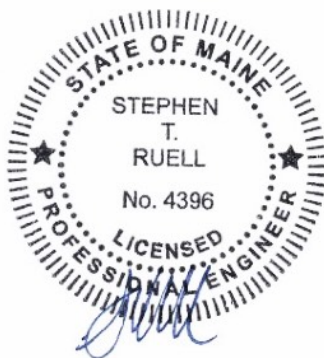

Pinnacle Hill Engineering

33 Pinnacle Road

Canaan, Maine 04924

Email: PinnacleHillEngineering@gmail.com

(207)858-5349

00 01 10
Table of Contents

Division 00 – Procurement and Contracting Requirements

<i>Section name</i>	<i>number of pages</i>
<u>INTRODUCTORY INFORMATION</u>	
00 01 01 Project Title Page	1
00 01 10 Table of Contents	2
<u>PROCUREMENT REQUIREMENTS</u>	
00 10 00 SOLICITATION	
00 11 00 Advertisements and Invitations	
00 11 12 Legal Advertisement	1
00 11 13 Notice to Contractors for Email Bid	2
00 20 00 INSTRUCTIONS FOR PROCUREMENT	
00 21 00 Instructions	
00 21 13 Instructions to Bidders	3
00 40 00 PROCUREMENT FORMS AND SUPPLEMENTS	
00 41 00 Bid Forms	
00 41 13 Contractor Bid Form	2
00 43 00 Procurement Form Supplements	
00 43 13 Contractor Bid Bond Sample	2
<u>CONTRACTING REQUIREMENTS</u>	
00 50 00 CONTRACTING FORMS AND SUPPLEMENTS	
00 52 00 Agreement Forms	
00 52 13 Construction Contract Sample	4
00 60 00 PROJECT FORMS	
00 62 00 Certificates and Other Forms	
00 62 76 Application for Payment Form	1
00 63 00 Clarification and Modification Forms	
00 63 46 Construction Change Directive Form	1
00 63 63 Change Order Form	1

00 01 10
Table of Contents

<i>Section name</i>	<i>number of pages</i>
00 70 00 CONDITIONS OF THE CONTRACT	
00 71 00 Definitions	
00 71 00 Definitions	6
00 72 00 General Conditions	
00 72 13 General Conditions	22
00 73 00 Supplementary Conditions	
00 73 46 Wage Determination Schedule	1
 Division 01 – General Requirements	
 01 00 00 GENERAL REQUIREMENTS	
 01 01 00 Summary of Work	
01 01 00 Work Covered by Contract Documents	2
 Appendix A – Plans	
Sheet 1 Floating Dock General Views	1
Sheet 2 Floating Dock General Sections	1
Sheet 3 Floating Dock Framing Plan	1
Sheet 4 Timber Skid Structure Plan	1
Sheet 5 Sections and Details	1
Sheet 6 Mooring Attachment and General Notes	1
 Appendix B – Reference Documents	
Ace Float Information	2

00 11 12

Legal Advertisement

NOTICE TO CONTRACTORS
INVITATION FOR BIDS

The Department of Agriculture, Conservation & Forestry is conducting a competitive bid process for the replacement of the existing 40 ft x 16 ft timber framed float at Eagle Island State Historic Site in Harpswell, Maine

Bids will be opened and read aloud by the Bureau of General Services at 2:00 p.m. on January 30, 2024.

The detailed *Notice to Contractors* is on the Bureau of General Services website: <https://www.maine.gov/dafs/bgs/business-opportunities> .

00 11 13
Notice to Contractors

Mooring and Float Upgrades
Eagle Island State Historic Site
Harpswell, Maine

BGS Project: 3481

Provide one 40 foot by 16 foot float as shown on the plans and deliver to the Eagle Island landing pier. Coordinate delivery with the Owner and connect the new float to the existing mooring system under the direction of the Owner. All labor, materials, and equipment are supplied by the Contractor.

The cost of the work is approximately \$ 60,000. The contract shall designate the Substantial Completion Date on or before **May 1, 2024**, and the Contract Final Completion Date on or before **May 15, 2024**.

1. Submit bids on a completed Contractor Bid Form, plus bid security when required, all scanned and included as an attachment to an email with the subject line marked "**Bid for Mooring and Float Upgrades Eagle Island**" and addressed to the Bid Administrator at: BGS.Architect@Maine.gov, so as to be received no later than **2:00:00 p.m. on January 30, 2024**.

Bid submissions will be opened and read aloud at the time and date noted above at the Bureau of General Services office, accessible as a video conference call. Those who wish to participate in the call must submit a request for access to BGS.Architect@Maine.gov.

Any bid received after the noted time will not be considered a valid bid and will remain unopened. Any bid submitted by any other means will not be considered a valid bid. The Bid Administrator may require the Bidder to surrender a valid paper copy of the bid form or the bid security document in certain circumstances.

Questions on the bid opening process shall be addressed to the Bid Administrator: Joseph H. Ostwald, Director, Division of Planning, Design & Construction, Bureau of General Services, 77 State House Station, Augusta, Maine 04333-0077, BGS.Architect@Maine.gov.

2. The bid shall be submitted on the Contractor Bid Form (section 00 41 13) provided in the Bid Documents. The Owner reserves the right to accept or reject any or all bids as may best serve the interest of the Owner.
3. Bid security *is required* on this project.
If noted above as required, the Bidder shall include a satisfactory Bid Bond (section 00 43 13) or a certified or cashier's check for 5% of the bid amount with the completed bid form submitted to the Owner. The Bid Bond form is available on the BGS website.
4. Performance and Payment Bonds are not required on this project.
5. Filed Sub-bids are not required on this project.
6. There are no Pre-qualified General Contractors on this project.

00 11 13
Notice to Contractors

7. An on-site pre-bid conference will not be conducted for this project.
8. Bid Documents are available at no cost as electronic PDF format files. Bid Documents will be distributed through the Bureau of General Services website:

<https://www.maine.gov/dafs/bgs/business-opportunities#invitationforbid>

Addenda and answers to questions will be posted on the BGS website. They will also be sent directly by email to bidders who have registered as Planholders with the Owner. Contact by email Matt.McGuire@maine.gov. Send an email with name and address and provide a return email address and phone number for receiving notices.

9. Bid Documents may be examined at:

AGC Maine

188 Whitten Road

Augusta, ME 04330

Phone 207-622-4741 Fax 207-622-1625

Construction Summary

734 Chestnut Street

Manchester, NH 03104

Phone 603-627-8856 Fax 603-627-4524

00 21 13
Instructions to Bidders

1. Bidder Requirements

- 1.1 A bidder is a Contractor who is qualified, or has been specifically pre-qualified by the Bureau of General Services, to bid on the proposed project described in the Bid Documents.
- 1.2 Contractors and Subcontractors bidding on projects that utilize Filed Sub-bids shall follow the requirements outlined in these Bid Documents for such projects. See Section 00 22 13 for additional information.
- 1.3 Contractors and Subcontractors are not eligible to bid on the project when their access to project design documents prior to the bid period distribution of documents creates an unfair bidding advantage. Prohibited access includes consultation with the Owner or with design professionals engaged by the Owner regarding cost estimating, constructability review, or project scheduling. This prohibition to bid applies to open, competitive bidding or pre-qualified contractor bidding or Filed Sub-bidding. The Bureau may require additional information to determine if the activities of a Contractor constitute an unfair bidding advantage.
- 1.4 Each bidder is responsible for becoming thoroughly familiar with the Bid Documents prior to submitting a bid. The failure of a bidder to review evident site conditions, to attend available pre-bid conferences, or to receive, examine, or act on addenda to the Bid Documents shall not relieve that bidder from any obligation with respect to their bid or the execution of the work as a Contractor.
- 1.5 Prior to the award of the contract, General Contractor bidders or Filed Sub-bidders may be required to provide documented evidence to the Owner or the Bureau showing compliance with the provisions of this section, their business experience, financial capability, or performance on previous projects.
- 1.6 The selected General Contractor bidder will be required to provide proof of insurance before a contract can be executed.
- 1.7 Contracts developed from this bid shall not be assigned, sublet or transferred without the written consent of the Owner.
- 1.8 By submitting a bid the Contractor attests that it has not been declared ineligible to bid on State of Maine projects. The Director of the Bureau of General Services may disallow award of this contract to any Contractor if there is evidence that the Contractor or any of its Subcontractors, through their own fault, have been terminated, suspended for cause, debarred from bidding, agreed to refrain from bidding as part of a settlement, have defaulted on a contract, or had a contract completed by another party.
- 1.9 The Contractor attests that it is not presently indicted for or otherwise criminally or civilly charged by a Federal, State or local government entity with commission of any of the following offenses and has not within a three-year period preceding this bid been convicted of or had a civil judgment rendered against them for commission of fraud or a criminal offense in connection with obtaining, attempting to obtain, or performing a public (Federal, State or local) transaction, or contract under a public transaction, violation of Federal or State anti-trust statutes or commission of embezzlement, theft, forgery, bribery, falsification or destruction of records, making false statements, or receiving stolen property.

00 21 13
Instructions to Bidders

- 1.10 The Contractor shall not make any award or permit any award (subgrant or contract) at any tier to any party which is debarred or suspended or is otherwise excluded from or ineligible for participation in Federal assistance programs or State of Maine projects.

2. Authority of Owner
 - 2.1 The Owner reserves the right to accept or reject any or all bids as may best serve the interest of the Owner.
 - 2.2 Subject to the Owner's stated right to accept or reject any or all bids, the Contractor shall be selected on the basis of the lowest dollar value of an acceptable Base Bid, or any combination of Base Bid plus Alternate Bids, as well as other limited cost modifications the Owner determines may best serve the interests of the Owner. An acceptable bid is a duly submitted bid from a responsive and responsible bidder.
 - 2.3 The Owner reserves the right to require Bid Bonds or Performance and Payment Bonds for any project of any contract value.

3. Submitting Bids and Bid Requirements
 - 3.1 Each bid shall be submitted on the forms provided in the Bid Documents.
 - 3.2 Each bid shall be valid for a period of thirty calendar days following the Project bid closing date and time. The bid expiration date may be extended in unusual circumstances by mutual consent of the Bidder and the Owner. The bid amount shall not be modified due to the bid expiration date extension.
 - 3.3 Any provision contained in a bid which shows cost escalation, or any modification of schedule or other requirements shall not be accepted. Such a provision causes the bid to be invalid, or, at the discretion of the Owner and BGS, that element of the bid submission may be disregarded for the purpose of awarding the contract without that provision.
 - 3.4 Bidders shall include a Bid Bond or other approved bid security with the bid form submitted to the Owner when the bid form indicates such bid security is required. The bond value shall be 5% of the bid amount. The form of bond is shown in section 00 43 13.
 - 3.5 Bidders recognize that inclusion of contract bonds and the cost of those bonds is dependent on the awarded contract dollar value. Therefore, a Base Bid, or any combination of Base Bid plus Alternate Bids, as well as other limited cost modifications, resulting in a contract award shall include the cost of Performance and Payment Bonds in the submitted bid amount when the construction contract value is over \$125,000.00. Similarly, the cost of Performance and Payment Bonds is excluded in the submitted bid amount when the construction contract value is \$125,000.00 or less unless bonds are specifically required by the Bid Documents. When required for the project, the selected Contractor shall provide these bonds before a contract can be executed, pursuant to 14 M.R.S.A., Section 871, Public Works Contractors' Surety Bond Law of 1971, subsection 3. The form of bonds is shown in section 00 61 13.13 and 00 61 13.16.

00 21 13
Instructions to Bidders

- 3.6 Bidders may modify bids in writing, by the same means as the original bid submission, prior to the bid closing time. Such written amendments shall not disclose the amount of the initial bid. If so disclosed, the entire bid is considered invalid.
- 3.7 Bidders implicitly acknowledge all Addenda issued when they submit the bid form. By usual practice the Consultant shall not issue Addenda less than 72 hours prior to the bid closing time, to allow ample time for bidders to incorporate the information. However, some information, such as extending the bid due date and time, may be issued with shorter notice. Addenda shall be issued to all companies who are registered holders of Bid Documents.
- 3.8 A bid may be withdrawn without penalty if a written request by the bidder is presented to the Owner prior to the bid closing time. Such written withdrawal requests are subject to verification as required by the Bureau. After the bid closing time, such written withdrawal requests may be allowed in consideration of the bid bond or, without utilizing a bid bond, if the Contractor provides documented evidence to the satisfaction of the Bureau that factual errors had been made on the bid form.
- 3.9 In the event State of Maine Offices unexpectedly close on the published date of a public bid opening in the location of that bid opening, prior to the time of the scheduled deadline, the new deadline for the public bid opening will be the following business day at the originally scheduled hour of the day, at the original location. Official closings are posted on the State of Maine government website.
- 3.10 The Owner may require, in a Notice of Intent to Award letter to the apparent low bidder, a Schedule of Values, Project Schedule, and List of Subcontractors and Suppliers as both a demonstration of capability of the Bidder and as a condition of award.
- 3.11 Projects which require a State of Maine wage determination will include that schedule as part of the Bid Documents. See section 00 73 46, if such rates are required.
- 3.12 Projects which require compliance with the Davis-Bacon Act are subject to the regulations contained the Code for Federal Regulations and the federal wage determination which is made a part of the Bid Documents. See section 00 73 46, if such rates are required.
- 3.13 The Owner is exempt from the payment of Maine State sales and use taxes as provided in 36 M.R.S. §1760 (1). The Contractor and Subcontractors shall not include taxes on exempt items in the construction contract.

**00 41 13
Contractor Bid Form**

Eagle Island State Historic Site Mooring and Float Upgrades

BGS 3481

Bid Form submitted by:

Bid Administrator:

Joseph Ostwald
Bureau of General Services
111 Sewall Street, Cross State Office Building, 4th floor
77 State House Station
Augusta, Maine 04333-0077

BGS.Architect@Maine.gov

Bidder:

Signature: _____

Printed name and title: _____

Company name: _____

Mailing address: _____

City, state, zip code: _____

Phone number: _____

Email address: _____

State of incorporation, if a corporation: _____

List of all partners, if a partnership: _____

The Bidder agrees, if the Owner offers to award the contract, to provide any and all bonds and certificates of insurance, as well as Schedule of Values, Project Schedule, and List of Subcontractors and Suppliers if required by the Owner, and to sign the designated Construction Contract within twelve calendar days after the date of notification of such acceptance, except if the twelfth day falls on a State of Maine government holiday or other closure day, or a Saturday, or a Sunday, in which case the aforementioned documents must be received before 12:00 noon on the first available business day following the holiday, other closure day, Saturday, or Sunday.

As a guarantee thereof, the Bidder submits, together with this bid, a bid bond or other acceptable instrument as and if required by the Bid Documents.

**00 41 13
Contractor Bid Form**

1. The Bidder, having carefully examined the *Mooring and Float Upgrades* Project Manual dated *28 December 2023*, prepared by *Pinnacle Hill Engineering*, as well as Specifications, Drawings, and any Addenda, the form of contract, and the premises and conditions relating to the work, proposes to furnish all labor, equipment and materials necessary for and reasonably incidental to the construction and completion of this project for the **Base Bid** amount of:

\$ _____.00

2. Allowances are not used on this project.
3. Alternate Bids are not used on this project.
4. Bid security is required on this project. The Bidder shall include with this bid form a satisfactory Bid Bond (section 00 43 13) or a certified or cashier's check for 5% of the bid amount with this completed bid form submitted to the Owner.
5. Filed Sub-bids are not used on this project

00 43 13
Contractor Bid Bond

Bond No.: **insert bond number**

We, the undersigned, **insert company name of Contractor**, of **insert name of municipality** in the State of **insert name of state** as principal, and **insert name of surety** as Surety, are hereby held and firmly bound unto in the penal sum of **five percent of the bid amount**, for the payment of which, well and truly to be made, we hereby jointly and severally bind ourselves, our heirs, executors, administrators, successors and assigns, signed this **insert date, i.e.: 8th** day of , , which is the same date as that of the first specified bid due date, or subsequent bid due date revised by addendum.

The condition of the above obligation is such that whereas the principal has submitted to the Owner, or State of Maine, to a certain bid, attached hereto and hereby made a part hereof, to enter into a contract in writing, for the construction of **insert name of project as designated in the contract documents**

Now therefore:

If said bid shall be rejected, or, in the alternate,

If said bid shall be accepted and the principal shall execute and deliver a contract in the form of contract attached hereto, properly completed in accordance with said bid, and shall furnish a bond for the faithful performance of said contract, and for the payment of all persons performing labor or furnishing material in connection therewith, and shall in all other respects perform the agreement created by the acceptance of said bid, then this obligation shall be void.

Otherwise, the same shall remain in force and effect- it being expressly understood and agreed that the liability of the Surety for any and all claims hereunder shall, in no event, exceed the penal amount of this obligation as herein stated.

The Surety, for value received hereby stipulates and agrees that the obligation of said Surety and its bonds shall be in no way impaired or affected by any extension of the time within which the Obligee may accept such bid and said Surety does hereby waive notice of any such extension.

**00 43 13
Contractor Bid Bond**

In witness whereof, the principal and the Surety have hereunto set their hands and seals, and such of them as are corporations have caused their corporate seals to be hereto affixed and these presents to be signed by their proper officers, the day and year first set above.

Signed and sealed this *insert date, i.e.: 8th* day of , , which is the first specified bid due date, or subsequent bid due date revised by addendum.

Contractor

(Signature)

insert name and title

insert company name

insert address

insert city state zip code

Surety

(Signature)

insert name and title

insert company name

insert address

insert city state zip code

If Contractor is a partnership, all partners shall execute the bond. A power of attorney document indicating that it still is in full force and effect shall be provided by the person executing this bond.

**State of Maine
CONSTRUCTION CONTRACT**

Large Construction Project

*This form is used when the Contract value is \$50,000 or greater.
The Project Manual, Specifications and Drawings, and any Addenda are considered part of this Contract.*

Agreement entered into by and between the contracting entity name hereinafter called the **Owner** and Contractor company name hereinafter called the **Contractor**.

BGS Project No.: number assigned by BGS Other Project No.: _____

For the following Project: title of project as shown on bid documents at facility or campus name, municipality, Maine.

The Specifications and the Drawings have been prepared by Consultant firm name, acting as Professional-of-Record and named in the documents as the Consultant Architect or Engineer.

The *Owner* and *Contractor* agree as follows:

ARTICLE 1 COMPENSATION AND PAYMENTS

1.1 The Owner shall pay the Contractor to furnish all labor, equipment, materials and incidentals necessary for the construction of the Work described in the Specifications and shown on the Drawings the Contract Amount as shown below.

Base Bid	\$0.00
<u>Alternate Bid number and name or "no Alternates"</u>	\$0.00
<u>Alternate Bid number and name or "no Alternates"</u>	\$0.00
<u>Alternate Bid number and name or "no Alternates"</u>	\$0.00
<u>Alternate Bid number and name or "no Alternates"</u>	\$0.00
<u>Alternate Bid number and name or "no Alternates"</u>	\$0.00
Total Contract Amount	\$0.00

1.2 The Contractor’s requisition shall contain sufficient detail and supporting information for the Owner to evaluate and support the payment requested.

1.2.1 Payments are due and payable twenty-five working days from the date of receipt of a Contractor requisition which is approved by the Owner.

1.2.2 Provisions for late payments are governed by 5 M.R.S. Chapter 144, *Payment of Invoices Received from Business Concerns*, and interest shall be calculated at 1% per month.

ARTICLE 2 COMMENCEMENT AND COMPLETION DATES

2.1 The Work of this Contract shall commence no sooner than the date this document is executed by the approval authority, or a subsequent date designated in the contract documents.

2.2 The Substantial Completion Date shall be _____.

2.3 The Work of this Contract shall be completed on or before the Contract Final Completion Date of _____.

2.4 The Contract Expiration Date shall be _____. (This date is the Owner's deadline for internal management of contract accounts. The Contract Expiration Date does not directly relate to any contract obligation of the Contractor.)

ARTICLE 3 INELIGIBLE BIDDER

3.1 By signing this contract the Contractor attests that it has not been declared ineligible to bid on State of Maine projects. The Bureau of General Services may disallow award of this contract to any Contractor if there is evidence that the Contractor or any of its Subcontractors, through their own fault, have been terminated, suspended for cause, debarred from bidding, agreed to refrain from bidding as part of a settlement, have defaulted on a contract, or had a contract completed by another party.

3.2 By signing this contract the Contractor attests that it is not presently indicted for or otherwise criminally or civilly charged by a Federal, State or local government entity with commission of any of the following offenses and has not within a three-year period preceding this bid been convicted of or had a civil judgment rendered against them for commission of fraud or a criminal offense in connection with obtaining, attempting to obtain, or performing a public (Federal, State or local) transaction, or contract under a public transaction, violation of Federal or State anti-trust statutes or commission of embezzlement, theft, forgery, bribery, falsification or destruction of records, making false statements, or receiving stolen property.

3.3 The Contractor shall not make any award or permit any award (subgrant or contract) at any tier to any party which is debarred or suspended or is otherwise excluded from or ineligible for participation in Federal assistance programs or State of Maine projects.

ARTICLE 4 CONTRACTOR'S RESPONSIBILITIES

4.1 On this project, the Contractor shall furnish the Owner the appropriate contract bonds in the amount of 100% of the Contract Sum. Contract bonds are mandated if the Contract Sum exceeds \$125,000, or if bonds are specifically required by the Contract Documents.

4.2 The Contractor shall comply with all laws, codes and regulations applicable to the Work.

4.3 The Contractor shall acquire all permits and third-party approvals applicable to the Work not specifically identified as provided by the Owner. Costs for Contractor-provided permits and third-party approvals shall be included in the Contract Sum identified in Section 1.1 above.

4.4 The Contractor shall remain an independent agent for the duration of this Contract, shall not become an employee of the State of Maine, and shall assure that no State employee will be compensated by, or otherwise benefit from, this Contract.

4.5 The Contractor shall be responsible for any design cost, construction cost, or other cost incurred on the Project to the extent caused by the negligent acts, errors or omissions of the Contractor or their Subcontractors in the performance of Work under this Contract.

ARTICLE 5 OWNER'S RESPONSIBILITIES

5.1 The Owner shall provide full information about the objectives, schedule, constraints and existing conditions of the project. The Owner has established a budget with reasonable contingencies that meets the project requirements.

5.2 By signing this contract, the Owner attests that all State of Maine procurement requirements for this contract have been met, including the solicitation of competitive bids.

ARTICLE 6 INSTRUMENTS OF SERVICE

6.1 The Contractor's use of the drawings, specifications and other documents known as the Consultant's Instruments of Service is limited to the execution of the Contractor's scope of work of this project unless the Contractor receives the written consent of the Owner and Consultant for use elsewhere.

ARTICLE 7 MISCELLANEOUS PROVISIONS

7.1 This Contract shall be governed by the laws of the State of Maine.

7.2 The Owner and Contractor, respectively, bind themselves, their partners, successors, assigns and legal representatives to this Contract. Neither party to this Contract shall assign the Contract as a whole without written consent of the other party, which consent the Owner may withhold without cause.

7.3 Notwithstanding any other provision of this Agreement, if the Owner does not receive sufficient funds to fund this Agreement or funds are de-appropriated, or if the Owner does not receive legal authority from the Maine State Legislature or Maine Courts to expend funds intended for this Agreement, then the Owner is not obligated to make payment under this Agreement; provided, however, the Owner shall be obligated to pay for services satisfactorily performed prior to any such non-appropriation in accordance with the termination provisions of this Agreement. The Owner shall timely notify the Contractor of any non-appropriation and the effective date of the non-appropriation.

ARTICLE 8 CONTRACT DOCUMENTS

8.1 The Project Manual, Specifications and Drawings, and any Addenda, together with this agreement, form the contract. Each element is as fully a part of the Contract as if hereto attached or herein repeated.

8.2 Specifications: **indicate date of issuance of project manual**

8.3 Drawings: **note here or attach each sheet number and title**

8.4 Addenda: **note each addenda number and date, or "none"**

BGS Project No.: _____

The Contract is effective as of the date executed by the approval authority.

OWNER

CONTRACTOR

Signature *Date*
name and title

Signature *Date*
name and title

name of contracting entity
address

name of contractor company
address

telephone
email address

telephone
email address
Vendor Number

Indicate the names of the review and approval individuals appropriate to the approval authority.

select proper approval authority			
Reviewed by:		Approved by:	
_____ <i>Signature</i>	_____ <i>Date</i>	_____ <i>Signature</i>	_____ <i>Date</i>
<i>insert name</i>		<i>Joseph H. Ostwald</i>	
<i>Project Manager/ Contract Administrator</i>		<i>Director, Planning, Design & Construction</i>	

**State of Maine
CONSTRUCTION CONTRACT
Application for Payment**

Project name
location / school / campus

Application Number: **1**

Contractor Company name
address
city state zip code

Period Start Date: **1-Jul-2021**
Period End Date: **31-Jul-2021**
BGS Project No.: **n**
Other Project No.: **x**

1	Original Contract Amount		\$0
2	Net of Change Orders to Date	(from table below)	\$0
3	Contract Sum to Date	(line 1 plus or minus line 2)	\$0
4	Total Completed and Stored to Date	(column G on Continuation Sheet)	\$0
5a	5% Retainage of Completed Work	(columns D + E x 5%)	\$0
5b	5% Retainage of Stored Materials	(column F x 5%)	\$0
5c	Total Retainage	(column I)	\$0
6	Total Earned Less Retainage	(line 4 minus line 5c)	\$0
7	Less Previous Approved Applications for Payment	(line 6 from previous Application)	\$0
8	Current Payment Due	(line 6 minus line 7)	\$0
9	Balance to Finish, Including Retainage	(line 3 minus line 6)	\$0

Change Order Summary	Additions	Deductions
Total Changes Approved in Previous Months	\$0	\$0
Total Changes Approved this Month	\$0	\$0
Subtotals	\$0	\$0
Net of Change Orders to Date		\$0

The undersigned Contractor certifies that to the best of the Contractor's knowledge, information, and belief the Work covered by this Application for Payment has been completed in accordance with the Contract Documents, that all amounts have been paid by the Contractor for Work for which the previous Certificates for Payment were issued and payments received from the Owner, and that current payment shown herein is now due.

Contractor
Type company name here
Type person's name, title here

signature date

In accordance with the Contract Documents, based on on-site observations and the data comprising this Application, the Consultant certifies to the Owner that to the best of the Consultant's knowledge, information, and belief the Work has progressed as indicated, the quality of the Work is in accordance with the Contract Documents, and the Contractor is entitled to payment of the Amount Certified. **Amount Certified:** _____

Consultant (Architect or Engineer)
Type firm name here
Type person's name, title here

signature date

Owner
Type contracting entity name here
Type person's name, title here

signature date

Owner's Rep / other - clear text if not used
Type entity name here
Type person's name, title here

signature date

Bureau of General Services
Type person's name, title here

signature date

State of Maine
CONSTRUCTION CONTRACT
Construction Change Directive

Project name
 location / school / campus

C. C. D. Number: **1**
 CP (Change Proposal) Number: **1**
 Issue Date of this Document: **31-Oct-2021**

Contractor Company name
 address
 city state zip code

BGS Project No.: **n**
 Other Project No.: **x**

CCD Item	Type name of CCD item here		
Description of Work	Type brief description here of work scope here.		
Reason or Necessity of Work	Type brief justification for change here.		
Method of Compensation	Select from drop down box...	Projected Total Cost	\$0
Supporting Documentation	is attached	Projected Calendar Days*	0

* Calendar Days refers to Contract Final Completion Date only.

Fully describe the scope of work of the CCD item in the table above and on attached drawings and specifications as necessary.

Indicate the reason for the work, and the estimated schedule and cost impacts.

This CCD records the order to do the work. The documented actual final time and cost changes are subject to approval in a subsequent Change Order process.

Consultant
 (Architect or Engineer) Type firm name here
 Type person's name, title here

 signature date

Contractor Type company name here
 Type person's name, title here

 signature date

Owner Type contracting entity name here
 Type person's name, title here

 signature date

Owner's Rep Type entity name here
 Type person's name, title here

 signature date

Bureau of
General Services Division of Planning, Design & Construction
 Type person's name, title here

 signature date

**State of Maine
CONSTRUCTION CONTRACT
Change Order**

Project name
location / school / campus

Change Order Number: **1**

Contractor Company name
address
city state zip code

Issue Date of this Document: **31-Dec-2022**

BGS Project No.: **n**
Other Project No.: **x**

Cost Change

Show Deduct as a negative number, e.g.: "-\$850".

	Add	Deduct	Total
Net Amount of this Change Order	\$0	\$0	
Net Amount of Previous Change Orders	\$0	\$0	
Net of Change Orders to Date	\$0	\$0	\$0
Original Contract Amount			\$0
Revised Contract Amount			\$0

Time Change

Show Deduct as a negative number, e.g.: "-8".

	Add	Deduct	Total
Net Calendar Days Adjusted by this Change Order	0	0	
Net Calendar Days Adjusted by Previous Change Orders	0	0	
Net of Change Orders to Date	0	0	0
Original Contract Final Completion Date			31-Dec-2023
Revised Contract Final Completion Date*			31-Dec-2023

Consultant (Architect or Engineer)

Type firm name here

Type person's name, title here

signature

date

Contractor

Type company name here

Type person's name, title here

signature

date

Owner

Type contracting entity name here

Type person's name, title here

signature

date

Type Entity, such as "Owner's Rep", or "not used"

Type entity name here

Type person's name, title here

signature

date

Bureau of General Services

Division of Planning, Design & Construction

Type person's name, title here

signature

date

Attach the "List of Change Order Items" sheet, plus all supporting documentation for each Change Order Item.

Substantial Completion Date: the deadline for first beneficial use by Owner, as certified by Consultant.

** **Contract Final Completion Date** : the Contractor's final completion deadline for contract work.*

Contract Expiration Date: the Owner's deadline for internal management of contract accounts;

Contract Expiration Date does not directly relate to any contract obligation of the Contractor.

<i>1-Dec-2023</i>

<i>31-Dec-2023</i>

<i>29-Feb-2024</i>

00 71 00
Definitions

1. Definitions
 - 1.1 *Addendum*: A document issued by the Consultant that amends the Bid Documents. Addenda shall not be issued less than seventy-two hours prior to the specified bid opening time.
 - 1.2 *Allowance*: A specified dollar amount for a particular scope of work or service included in the Work that is identified in the Bid Documents and included in each Bidder's Bid. The Contractor shall document expenditures for an Allowance during the Project. Any unused balance shall be credited to the Owner. The Contractor is responsible for notifying the Owner of anticipated expenses greater than the specified amount and the Owner is responsible for those additional expenses.
 - 1.3 *Alternate Bid*: The Contractor's written offer of a specified dollar amount, submitted on the Bid Form, for the performance of a particular scope of work described in the Bid Documents. The Owner determines the low bidder based on the sum of the base Bid and any combination of Alternate Bids that the Owner selects.
 - 1.4 *Architect*: A Consultant acting as, or supporting, the Professional-of-Record who is responsible for the design of the Project. Equivalent to "Consultant" in State of Maine contract forms.
 - 1.5 *Architectural Supplemental Instruction (ASI)*: A written instruction from the Architect for the purpose of clarification of the Contract Documents. An ASI does not alter the Contract Price or Contract Time. ASIs may be responses to RFIs and shall be issued by the Architect in a timely manner to avoid any negative impact on the Schedule of the Work.
 - 1.6 *Bid*: The Contractor's written offer of a specified dollar amount or amounts, submitted on a form included in the Bid Documents, for the performance of the Work. A Bid may include bonds or other requirements. A base Bid is separate and distinct from Alternate Bids, being the only cost component necessary for the award of the contract, and representing the minimum amount of Work that is essential for the functioning of the Project.
 - 1.7 *Bid Bond*: The security designated in the Bid Documents, furnished by Bidders as a guaranty of good faith to enter into a contract with the Owner, should a contract be awarded to that Bidder.
 - 1.8 *Bidder*: Any business entity, individual or corporation that submits a bid for the performance of the work described in the Bid Documents, acting directly or through a duly authorized representative. See also *Responsive and Responsible Bidder*.
 - 1.9 *Bid Documents*: The drawings, procurement and contracting requirements, general requirements, and the written specifications -including all addenda, that a bidder is required to reference in the submission of a bid.
 - 1.10 *Bureau*: The State of Maine Bureau of General Services, or BGS, in the Department of Administrative and Financial Services.
 - 1.11 *Calendar days*: Consecutive days, as occurring on a calendar, taking into account each day of the week, month, year, and any religious, national or local holidays. Calendar days are used for changes in Contract Time.

00 71 00
Definitions

- 1.12 *Certificate of Substantial Completion*: A document developed by the Consultant that describes the final status of the Work and establishes the date that the Owner may use the facility for its intended purpose. The Certificate of Substantial Completion may also include a provisional list of items - a "punch list" - remaining to be completed by the Contractor. The Certificate of Substantial Completion identifies the date from which the project warranty period commences.
- 1.13 *Certificate of Occupancy*: A document developed by a local jurisdiction such as the Code Enforcement Officer that grants permission to the Owner to occupy a building.
- 1.14 *Change Order (CO)*: A document that modifies the contract and establishes the basis of a specific adjustment to the Contract Price or the Contract Time, or both. Change Orders may address correction of omissions, errors, and document discrepancies, or additional requirements. Change Orders should include all labor, materials and incidentals required to complete the work described. A Change Order is not valid until signed by the Contractor, Owner and Consultant and approved by the Bureau.
- 1.15 *Change Order Proposal (COP) (see also Proposal)*: Contract change proposed by the Contractor regarding the contract amount, requirements, or time. The Contractor implements the work of a COP after it is accepted by all parties. Accepted COPs are incorporated into the contract by Change Order.
- 1.16 *Clerk of the Works*: The authorized representative of the Consultant on the job site. Clerk of the Works is sometimes called the Architect's representative.
- 1.17 *Construction Change Directive (CCD)*: A written order prepared by the Consultant and signed by the Owner and Consultant, directing a change in the Work prior to final agreement with the Contractor on adjustment, if any, in the Contract Price or Contract Time, or both.
- 1.18 *Contract*: A written agreement between the Owner and the successful bidder which obligates the Contractor to perform the work specified in the Contract Documents and obligates the Owner to compensate the Contractor at the mutually accepted sum, rates or prices.
- 1.19 *Contract Bonds (also known as Payment and Performance Bonds)*: The approved forms of security, furnished by the Contractor and their surety, which guarantee the faithful performance of all the terms of the contract and the payment of all bills for labor, materials and equipment by the Contractor.
- 1.20 *Contract Documents*: The drawings and written specifications (including all addenda), Standard General Conditions, and the contract (including all Change Orders subsequently incorporated in the documents).
- 1.21 *Contract Expiration Date*: Date determined by the Owner as a deadline for internal management of contract accounts. This allows time after the Contract Final Completion Date for processing the final Requisition for Payment. The Contract Expiration Date does not directly relate to any contract obligation of the Contractor.
- 1.22 *Contract Final Completion Date*: Point of time when the Work is fully completed in compliance with the Contract Documents, as certified by the Consultant. Final payment to the Contractor is due upon Final Completion of the Project.
- 1.23 *Contract Price*: The dollar amount of the construction contract, also called *Contract Sum*.

00 71 00
Definitions

- 1.24 *Contract Time*: The designated duration of time to execute the Work of the contract, with a specific date for completion.
- 1.25 *Contractor*: Also called the "General Contractor" or "GC" the individual or entity undertaking the execution of the general contract work under the terms of the contract with the Owner, acting directly or through a duly authorized representative. The Contractor is responsible for the means, methods and materials utilized in the execution and completion of the Work.
- 1.26 *Consultant*: The Architect or Engineer acting as Professional-of-Record for the Project. The Consultant is responsible for the design of the Project.
- 1.27 *Drawings*: The graphic and pictorial portion of the Contract Documents showing the design, location and dimensions of the Work, generally including plans, elevations, sections, details, schedules, and diagrams.
- 1.28 *Engineer*: A Consultant acting as, or supporting, the Professional-of-Record who is responsible for the design of the Project. Equivalent to "Consultant" in State of Maine contract forms.
- 1.29 *Filed Sub-bid*: The designated major Subcontractor's (or, in some cases, Contractor's) written offer of a specified dollar amount or amounts, submitted on a form included in the Bid Documents, for the performance of a particular portion of the Work. A Filed Sub-bid may include bonds or other requirements.
- 1.30 *General Requirements*: The on-site overhead expense items the Contractor provides for the Project, typically including, but not limited to, building permits, construction supervision, Contract Bonds, insurance, field office, temporary utilities, rubbish removal, and site fencing. Overhead expenses of the Contractor's general operation are not included. Sometimes referred to as the Contractor's General Conditions.
- 1.31 *Owner*: The State agency which is represented by duly authorized individuals. The Owner is responsible for defining the scope of the Project and compensation to the Consultant and Contractor.
- 1.32 *Owner's Representative*: The individual or entity contracted by the Owner to be an advisor and information conduit regarding the Project.
- 1.33 *Overhead*: General and administrative expenses of the Contractor's principal and branch offices, including payroll costs and other compensation of Contractor employees, deductibles paid on any insurance policy, charges against the Contractor for delinquent payments, and costs related to the correction of defective work, and the Contractor's capital expenses, including interest on capital used for the work.
- 1.34 *Performance and Payment Bonds (also known as Contract Bonds)*: The approved forms of security, furnished by the Contractor and their surety, which guarantee the faithful performance of all the terms of the contract and the payment of all bills for labor, materials and equipment by the Contractor.
- 1.35 *Post-Bid Addendum*: Document issued by the Consultant that defines a potential Change Order prior to signing of the construction contract. The Post-Bid Addendum allows the Owner to negotiate

00 71 00
Definitions

contract changes with the Bidder submitting the lowest valid bid, only if the negotiated changes to the Bid Documents result in no change or no increase in the bid price.

A Post-Bid Addendum may also be issued after a competitive construction Bid opening to those Bidders who submitted a Bid initially, for the purpose of rebidding the Project work without re-advertising.

- 1.36 *Project*: The construction project proposed by the Owner to be constructed according to the Contract Documents. The Project, a public improvement, may be tied logistically to other public improvements and other activities conducted by the Owner or other contractors.
- 1.37 *Proposal (see also Change Order Proposal)*: The Contractor's written offer submitted to the Owner for consideration containing a specified dollar amount or rate, for a specific scope of work, and including a schedule impact, if any. A proposal shall include all costs for overhead and profit. The Contractor implements the work of a Proposal after it is accepted by all parties. Accepted Proposals are incorporated into the contract by Change Order.
- 1.38 *Proposal Request (PR)*: An Owner's written request to the Contractor for a Change Order Proposal.
- 1.39 *Punch List*: A document that identifies the items of work remaining to be done by the Contractor at the Close Out of a Project. The Punch List is created as a result of a final inspection of the work only after the Contractor attests that all of the Work is in its complete and permanent status.
- 1.40 *Request For Information (RFI)*: A Contractor's written request to the Consultant for clarification, definition or description of the Work. RFIs shall be presented by the Contractor in a timely manner to avoid any negative impact on the Schedule of the Work.
- 1.41 *Request For Proposal (RFP)*: An Owner's written request to the Contractor for a Change Order Proposal.
- 1.42 *Requisition for Payment*: The document in which the Contractor certifies that the Work described is, to the best of the Contractor's knowledge, information and belief, complete and that all previous payments have been paid by the Contractor to Subcontractors and suppliers, and that the current requested payment is now due. See *Schedule of Values*.
- 1.43 *Responsive and Responsible Bidder*: A bidder who complies, when submitting a bid on a given project, with the following *responsive* standards, as required by the Bid Documents:
- submits specific qualifications to bid the project, if required;
 - attends mandatory pre-bid conferences, if required;
 - submits a bid prior to the close of the bid period;
 - submits a complete bid form;
 - submits a bid without indications of intent contrary to the stated requirements;
 - submits other materials and information, such as bid security, as required;
- and, meets the following minimums regarding these *responsible* standards:
- sustains a satisfactory record of project performance;
 - maintains a permanent place of business in a known physical location;
 - possesses the financial means for short- and long-term operations;
 - possesses the appropriate technical experience and capabilities;
 - employs adequate personnel and subcontractor resources;

00 71 00
Definitions

maintains the equipment needed to perform the work;
complies with the proposed implementation schedule;
complies with the insurance and bonding requirements;
provides post-construction warranty coverage;
and other criteria which can be considered relevant to the contract.

- 1.44 *Retainage*: The amount, calculated at five percent (5%) of the contract value or a scheduled value, that the Owner shall withhold from the Contractor until the work or portion of work is declared substantially complete or otherwise accepted by the Owner. The Owner may, if requested, reduce the amount withheld if the Owner deems it desirable and prudent to do so. (See Title 5 M.R.S.A., Section 1746.)
- 1.45 *Sample*: A physical example provided by the Contractor which illustrates materials, equipment or workmanship and establishes standards by which the Work will be judged.
- 1.46 *Schedule of the Work*: The document prepared by the Contractor and approved by the Owner that specifies the dates on which the Contractor plans to begin and complete various parts of the Work, including dates on which information and approvals are required from the Owner.
- 1.47 *Schedule of Values*: The document prepared by the Contractor and approved by the Owner before the commencement of the Work that specifies the dollar values of discrete portions of the Work equal in sum to the contract amount. The Schedule of Values is used to document progress payments of the Work in regular (usually monthly) requisitions for payment. See *Requisition for Payment*.
- 1.48 *Shop Drawings*: The drawings, diagrams, schedules and other data specially prepared for the Work by the Contractor or a Subcontractor, manufacturer, supplier or distributor to illustrate some portion of the Work.
- 1.49 *Specifications*: The portion of the Contract Documents consisting of the written requirements of the Work for materials, equipment, systems, standards, workmanship, and performance of related services.
- 1.50 *Subcontractor*: An individual or entity undertaking the execution of any part of the Work by virtue of a written agreement with the Contractor or any other Subcontractor. Also, an individual or entity retained by the Contractor or any other Subcontractor as an independent contractor to provide the labor, materials, equipment or services necessary to complete a specific portion of the Work.
- 1.51 *Substantial Completion Date*: Point of time when the Work or a designated portion of the Work is sufficiently complete in compliance with the Contract Documents so that the Owner can occupy or utilize the Work for its intended purpose without unscheduled disruption. Substantial Completion is documented by the date of the Certificate of Substantial Completion signed by the Owner and the Contractor.
- 1.52 *Superintendent*: The representative of the Contractor on the job site, authorized by the Contractor to receive and fulfill instructions from the Consultant.
- 1.53 *Surety*: The individual or entity that is legally bound with the Contractor and Subcontractor to insure the faithful performance of the contract and for the payment of the bills for labor, materials and equipment by the Contractor and Subcontractors.

00 71 00
Definitions

- 1.54 *Work*: The construction and services, whether completed or partially completed, including all labor, materials, equipment and services provided or to be provided by the Contractor and Subcontractors to fulfill the requirements of the Project as described in the Contract Documents.

00 72 13
General Conditions

Table of Contents of this General Conditions Section

1. Preconstruction Conference2

2. Intent and Correlation of Contract Documents.....2

3. Additional Drawings and Specifications3

4. Ownership of Contract Documents3

5. Permits, Laws, and Regulations3

6. Taxes4

7. Labor and Wages.....4

8. Indemnification5

9. Insurance Requirements5

10. Contract Bonds.....6

11. Patents and Royalties7

12. Surveys, Layout of Work7

13. Record of Documents.....7

14. Allowances8

15. Shop Drawings8

16. Samples8

17. Substitutions8

18. Assignment of Contract.....9

19. Separate Contracts.....9

20. Subcontracts10

21. Contractor-Subcontractor Relationship10

22. Supervision of the Work.....11

23. Observation of the Work11

24. Consultant's Status.....12

25. Management of the Premises12

26. Safety and Security of the Premises13

27. Changes in the Work14

28. Correction of the Work.....15

29. Owner's Right to do Work.....16

30. Termination of Contract and Stop Work Action16

31. Delays and Extension of Time17

32. Payments to the Contractor18

33. Payments Withheld19

34. Liens19

35. Workmanship19

36. Close-out of the Work20

37. Date of Completion and Liquidated Damages21

38. Dispute Resolution21

00 72 13
General Conditions

1. Preconstruction Conference

- 1.1 The Contractor shall, upon acceptance of a contract and prior to commencing work, schedule a preconstruction conference with the Owner and Consultant. The purpose of this conference is as follows.
- 1.1.1 Introduce all parties who have a significant role in the Project, including:
Owner (State agency or other contracting entity)
 Owner's Representative
Consultant (Architect or Engineer)
 Subconsultants
 Clerk-of-the-works
Contractor (GC)
 Superintendent
 Subcontractors
Other State agencies
Construction testing company
Commissioning agent
Special Inspections agent
Bureau of General Services (BGS);
- 1.1.2 Review the responsibilities of each party;
- 1.1.3 Review any previously-identified special provisions of the Project;
- 1.1.4 Review the Schedule of the Work calendar submitted by the Contractor to be approved by the Owner and Consultant;
- 1.1.5 Review the Schedule of Values form submitted by the Contractor to be approved by the Owner and Consultant;
- 1.1.6 Establish routines for Shop Drawing approval, contract changes, requisitions, et cetera;
- 1.1.7 discuss jobsite issues;
- 1.1.8 Discuss Project close-out procedures;
- 1.1.9 Provide an opportunity for clarification of Contract Documents before work begins; and
- 1.1.10 Schedule regular meetings at appropriate intervals for the review of the progress of the Work.

2. Intent and Correlation of Contract Documents

- 2.1 The intent of the Contract Documents is to describe the complete Project. The Contract Documents consist of various components; each component complements the others. What is shown as a requirement by any one component shall be inferred as a requirement on all corresponding components.
- 2.2 The Contractor shall furnish all labor, equipment and materials, tools, transportation, insurance, services, supplies, operations and methods necessary for, and reasonably incidental to, the construction and completion of the Project. Any work that deviates from the Contract Documents which appears to be required by the exigencies of construction or by inconsistencies in the Contract Documents, will be determined by the Consultant and authorized in writing by the Consultant, Owner and the Bureau prior to execution. The Contractor shall be responsible for requesting clarifying information where the intent of the Contract Documents is uncertain.
- 2.3 The Contractor shall not utilize any apparent error or omission in the Contract Documents to the disadvantage of the Owner. The Contractor shall promptly notify the Consultant in writing of such errors or omissions. The Consultant shall make any corrections or clarifications necessary in such a situation to document the true intent of the Contract Documents.

00 72 13
General Conditions

3. Additional Drawings and Specifications

- 3.1 Upon the written request of the Contractor, the Owner shall provide, at no expense to the Contractor, up to five sets of printed Drawings and Specifications for the execution of the Work.
- 3.2 The Consultant shall promptly furnish to the Contractor revised Drawings and Specifications, for the area of the documents where those revisions apply, when corrections or clarifications are made by the Consultant. All such information shall be consistent with, and reasonably inferred from, the Contract Documents. The Contractor shall do no work without the proper Drawings and Specifications.

4. Ownership of Contract Documents

- 4.1 The designs represented on the Contract Documents are the property of the Consultant. The Drawings and Specifications shall not be used on other work without consent of the Consultant.

5. Permits, Laws, and Regulations

- 5.1 The Owner is responsible for obtaining any zoning approvals or other similar local project approvals necessary to complete the Work, unless otherwise specified in the Contract Documents.
- 5.2 The Owner is responsible for obtaining Maine Department of Environmental Protection, Maine Department of Transportation, or other similar state government project approvals necessary to complete the Work, unless otherwise indicated in the Contract Documents.
- 5.3 The Owner is responsible for obtaining any federal agency project approvals necessary to complete the Work, unless otherwise indicated in the Contract Documents.
- 5.4 The Owner is responsible for obtaining all easements for permanent structures or permanent changes in existing facilities.
- 5.5 The Contractor is responsible for obtaining and paying for all permits and licenses necessary for the implementation of the Work. The Contractor shall notify the Owner of any delays, variance or restrictions that may result from the issuing of permits and licenses.
- 5.6 The Contractor shall comply with all ordinances, laws, rules and regulations and make all required notices bearing on the implementation of the Work. In the event the Contractor observes disagreement between the Drawings and Specifications and any ordinances, laws, rules and regulations, the Contractor shall promptly notify the Consultant in writing. Any necessary changes shall be made as provided in the contract for changes in the work. The Contractor shall not perform any work knowing it to be contrary to such ordinances, laws, rules and regulations.
- 5.7 The Contractor shall comply with local, state and federal regulations regarding construction safety and all other aspects of the Work.
- 5.8 The Contractor shall comply with the Maine Code of Fair Practices and Affirmative Action, 5 M.R.S. §784 (2).

00 72 13
General Conditions

6. Taxes

- 6.1 The Owner is exempt from the payment of Maine State sales and use taxes as provided in 36 M.R.S. §1760 (1). The Contractor and Subcontractors shall not include taxes on exempt items in the construction contract.
- 6.2 Section 1760 further provides in subsection 61 that sales to a construction contractor or its subcontractor of tangible personal property that is to be physically incorporated in, and become a permanent part of, real property for sale to or owned by the Owner, are exempt from Maine State sales and use taxes. Tangible personal property is defined in 36 M.R.S. §1752 (17).
- 6.3 The Contractor may contact Maine Revenue Services, 24 State House Station, Augusta, Maine 04333 for guidance on tax exempt regulations authorized by 36 M.R.S. §1760 and detailed in Rule 302 (18-125 CMR 302).

7. Labor and Wages

- 7.1 The Contractor shall conform to the labor laws of the State of Maine, and all other laws, ordinances, and legal requirements affecting the work in Maine.
- 7.2 The Consultant shall include a wage determination document prepared by the Maine Department of Labor in the Contract Documents for state-funded contracts in excess of \$50,000. The document shows the minimum wages required to be paid to each category of labor employed on the project.
- 7.3 On projects requiring a Maine wage determination, the Contractor shall submit monthly payroll records to the Owner ("the contracting agency") showing the name and occupation of all workers and all independent contractors employed on the project. The monthly submission must also include the Contractor's company name, the title of the project, hours worked, hourly rate or other method of remuneration, and the actual wages or other compensation paid to each person.
- 7.4 The Contractor shall not reveal, in the payroll records submitted to the Owner, personal information regarding workers and independent contractors, other than the information described above. Such information shall not include Social Security number, employee identification number, or employee address or phone number, for example.
- 7.5 The Contractor shall conform to Maine statute (39-A M.R.S. §105-A (6)) by providing to the Workers' Compensation Board a list of all subcontractors and independent contractors on the job site and a record of the entity to whom that subcontractor or independent contractor is directly contracted and by whom that subcontractor or independent contractor is insured for workers' compensation purposes.
- 7.6 The Contractor shall enforce strict discipline and good order among their employees at all times, and shall not employ any person unfit or unskilled to do the work assigned to them.
- 7.7 The Contractor shall promptly pay all employees when their compensation is due, shall promptly pay all others who have billed and are due for materials, supplies and services used in the Work, and shall promptly pay all others who have billed and are due for insurance, workers compensation coverage, federal and state unemployment compensation, and Social Security

00 72 13
General Conditions

charges pertaining to this Project. Before final payments are made, the Contractor shall furnish to the Owner affidavits that all such payments described above have been made.

- 7.8 The Contractor may contact the Maine Department of Labor, 54 State House Station, Augusta, Maine 04333 for guidance on labor issues.
- 7.9 The Contractor may contact the Maine Workers' Compensation Board, 27 State House Station, Augusta, Maine 04333 for guidance on workers' compensation issues.

8. Indemnification

- 8.1 The Contractor shall indemnify and hold harmless the Owner and its officers and employees from and against any and all damages, liabilities, and costs, including reasonable attorney's fees, and defense costs, for any and all injuries to persons or property, including claims for violation of intellectual property rights, to the extent caused by the negligent acts or omissions of the Contractor, its employees, agents, officers or subcontractors in the performance of work under this Agreement. The Contractor shall not be liable for claims to the extent caused by the negligent acts or omissions of the Owner or for actions taken in reasonable reliance on written instructions of the Owner.
- 8.2 The Contractor shall notify the Owner promptly of all claims arising out of the performance of work under this Agreement by the Contractor, its employees or agents, officers or subcontractors.
- 8.3 This indemnity provision shall survive the termination of the Agreement, completion of the project or the expiration of the term of the Agreement.

9. Insurance Requirements

- 9.1 The Contractor shall provide, with each original of the signed Contract, an insurance certificate or certificates acceptable to the Owner and BGS. The Contractor shall submit insurance certificates to the Owner and BGS at the commencement of this Contract and at policy renewal or revision dates. The certificates shall identify the project name and BGS project number, and shall name the Owner as certificate holder and as additional insured for general liability and automobile liability coverages. The submitted forms shall contain a provision that coverage afforded under the insurance policies will not be canceled or materially changed unless at least ten days prior written notice by registered letter has been given to the Owner and BGS.
- 9.2 The Owner does not warrant or represent that the insurance required herein constitutes an insurance portfolio which adequately addresses all risks faced by the Contractor or its Subcontractors. The Contractor is responsible for the existence, extent and adequacy of insurance prior to commencement of work. The Contractor shall not allow any Subcontractor to commence work until all similar insurance required of the Subcontractor has been confirmed by the Contractor.
- 9.3 The Contractor shall procure and maintain primary insurance for the duration of the Project and, if written on a Claims-Made basis, shall also procure and maintain Extended Reporting Period (ERP) insurance for the period of time that any claims could be brought. The Contractor shall ensure that all Subcontractors they engage or employ will procure and maintain similar insurance

**00 72 13
General Conditions**

in form and amount acceptable to the Owner and BGS. At a minimum, the insurance shall be of the types and limits set forth herein protecting the Contractor from claims which may result from the Contractor's execution of the Work, whether such execution be by the Contractor or by those employed by the Contractor or by those for whose acts they may be liable. All required insurance coverages shall be placed with carriers authorized to conduct business in the State of Maine by the Maine Bureau of Insurance.

9.3.1 The Contractor shall have Workers' Compensation insurance for all employees on the Project site in accordance with the requirements of the Workers' Compensation law of the State of Maine. Minimum acceptable limits for Employer's Liability are:

Bodily Injury by Accident.....	\$500,000
Bodily Injury by Disease.....	\$500,000 Each Employee
Bodily Injury by Disease.....	\$500,000 Policy Limit

9.3.2 The Contractor shall have Commercial General Liability insurance providing coverage for bodily injury and property damage liability for all hazards of the Project including premise and operations, products and completed operations, contractual, and personal injury liabilities. The policy shall include collapse and underground coverage as well as explosion coverage if explosion hazards exist. Aggregate limits shall apply on a location or project basis. Minimum acceptable limits are:

General aggregate limit.....	\$2,000,000
Products and completed operations aggregate	\$1,000,000
Each occurrence limit.....	\$1,000,000
Personal injury aggregate.....	\$1,000,000

9.3.3 The Contractor shall have Automobile Liability insurance against claims for bodily injury, death or property damage resulting from the maintenance, ownership or use of all owned, non-owned and hired automobiles, trucks and trailers. Minimum acceptable limit is:
Any one accident or loss\$500,000

9.3.4 For the portion of a project which is new construction, the Contractor shall procure and maintain Builder's Risk insurance naming the Owner, Contractor, and any Subcontractor as insureds as their interest may appear. Covered causes of loss form shall be all Risks of Direct Physical Loss, endorsed to include flood, earthquake, transit and sprinkler leakage where sprinkler coverage is applicable. Unless specifically authorized in writing by the Owner, the limit of insurance shall not be less than the initial contract amount, for the portion of the project which is new construction, and coverage shall apply during the entire contract period and until the work is accepted by the Owner.

9.3.5 The Contractor shall have Owner's Protective Liability insurance for contract values \$50,000 and above, naming the Owner as the Named Insured. Minimum acceptable limits are:
General aggregate limit.....\$2,000,000
Each occurrence limit.....\$1,000,000

10. Contract Bonds

10.1 When noted as required in the Bid Documents, the Contractor shall provide to the Owner a Performance Bond and a Payment Bond, or "contract bonds", upon execution of the contract. Each bond value shall be for the full amount of the contract and issued by a surety company authorized to do business in the State of Maine as approved by the Owner. The bonds shall be

00 72 13
General Conditions

executed on the forms furnished in the Bid Documents. The bonds shall allow for any subsequent additions or deductions of the contract.

- 10.2 The contract bonds shall continue in effect for one year after final acceptance of the contract to protect the Owner's interest in connection with the one year guarantee of workmanship and materials and to assure settlement of claims for the payment of all bills for labor, materials and equipment by the Contractor.

11. Patents and Royalties

- 11.1 The Contractor shall, for all time, secure for the Owner the free and undisputed right to the use of any patented articles or methods used in the Work. The expense of defending any suits for infringement or alleged infringement of such patents shall be borne by the Contractor. Awards made regarding patent suits shall be paid by the Contractor. The Contractor shall hold the Owner harmless regarding patent suits that may arise due to installations made by the Contractor, and to any awards made as a result of such suits.
- 11.2 Any royalty payments related to the work done by the Contractor for the Project shall be borne by the Contractor. The Contractor shall hold the Owner harmless regarding any royalty payments that may arise due to installations made by the Contractor.

12. Surveys, Layout of Work

- 12.1 The Owner shall furnish all property surveys unless otherwise specified.
- 12.2 The Contractor is responsible for correctly staking out the Work on the site. The Contractor shall employ a competent surveyor to position all construction on the site. The surveyor shall run the axis lines, establish correct datum points and check each line and point on the site to insure their accuracy. All such lines and points shall be carefully preserved throughout the construction.
- 12.3 The Contractor shall lay out all work from dimensions given on the Drawings. The Contractor shall take measurements and verify dimensions of any existing work that affects the Work or to which the Work is to be fitted. The Contractor is solely responsible for the accuracy of all measurements. The Contractor shall verify all grades, lines, levels, elevations and dimensions shown on the Drawings and report any errors or inconsistencies to the Consultant prior to commencing work.

13. Record of Documents

- 13.1 The Contractor shall maintain one complete set of Contract Documents on the jobsite, in good order and current status, for access by the Owner and Consultant.
- 13.2 The Contractor shall maintain, continuously updated, complete records of Requests for Information, Architectural Supplemental Instructions (or equivalent), Information Bulletins, supplemental sketches, Change Order Proposals, Change Orders, Shop Drawings, testing reports, et cetera, for access by the Owner and Consultant.

00 72 13
General Conditions

14. Allowances

- 14.1 The Contract Price shall include all allowances described in the Contract Documents. The Contractor shall include all overhead and profit necessary to implement each allowance in their Contract Price.
- 14.2 The Contractor shall not be required to employ parties for allowance work against whom the Contractor has a reasonable objection. In such a case, the Contractor shall notify the Owner in writing of their position and shall propose an alternative party to complete the work of the allowance.

15. Shop Drawings

- 15.1 The Contractor shall administer Shop Drawings prepared by the Contractor, Subcontractors, suppliers or others to conform to the approved Schedule of the Work. The Contractor shall verify all field measurements, check and authorize all Shop Drawings and schedules required by the Work. The Contractor is the responsible party and contact for the Contractor's work as well as that of Subcontractors, suppliers or others who provide Shop Drawings.
- 15.2 The Consultant shall review and acknowledge Shop Drawings, with reasonable promptness, for general conformity with the design concept of the project and compliance with the information provided in the Contract Documents.
- 15.3 The Contractor shall provide monthly updated logs containing: requests for information, information bulletins, supplemental instructions, supplemental sketches, change order proposals, change orders, submittals, testing and deficiencies.
- 15.4 The Contractor shall make any corrections required by the Consultant, and shall submit a quantity of corrected copies as may be needed. The acceptance of Shop Drawings or schedules by the Consultant shall not relieve the Contractor from responsibility for deviations from Drawings and Specifications, unless the Contractor has called such deviations to the attention of the Consultant at the time of submission and secured the Consultant's written approval. The acceptance of Shop Drawings or schedules by the Consultant does not relieve the Contractor from responsibility for errors in Shop Drawings or schedules.

16. Samples

- 16.1 The Contractor shall furnish for approval, with reasonable promptness, all samples as directed by the Consultant. The Consultant shall review and approve such samples, with reasonable promptness, for general conformity with the design concept of the project and compliance with the information provided in the Contract Documents. The subsequent work shall be in accord with the approved samples.

17. Substitutions

- 17.1 The Contractor shall furnish items and materials described in the Contract Documents. If the item or material specified describes a proprietary product, or uses the name of a manufacturer, the term "or approved equal" shall be implied, if it is not included in the text. The specific item or material specified establishes a minimum standard for the general design, level of quality, type, function, durability, efficiency, reliability, compatibility, warranty coverage, installation factors

00 72 13
General Conditions

and required maintenance. The Drawing or written Specification shall not be construed to exclude other manufacturers products of comparable design, quality, and efficiency.

- 17.2 The Contractor may submit detailed information about a proposed substitution to the Consultant for consideration. Particular models of items and particular materials which the Contractor asserts to be equal to the items and materials identified in the Contract Documents shall be allowed only with written approval by the Consultant. The request for substitution shall include a cost comparison and a reason or reasons for the substitution.
- 17.3 The Consultant may request additional information about the proposed substitution. The approval or rejection of a proposed substitution may be based on timeliness of the request, source of the information, the considerations of minimum standards described above, or other considerations. The Consultant should briefly state the rationale for the decision. The decision shall be considered final.
- 17.4 The duration of a substitution review process can not be the basis for a claim for delay in the Schedule of the Work.

18. Assignment of Contract

- 18.1 The Contractor shall not assign or sublet the contract as a whole without the written consent of the Owner. The Contractor shall not assign any money due to the Contractor without the written consent of the Owner.

19. Separate Contracts

- 19.1 The Owner reserves the right to create other contracts in connection with this Project using similar General Conditions. The Contractor shall allow the Owner's other contractors reasonable opportunity for the delivery and storage of materials and the execution of their work. The Contractor shall coordinate and properly connect the Work of all contractors.
- 19.2 The Contractor shall promptly report to the Consultant and Owner any apparent deficiencies in work of the Owner's other contractors that impacts the proper execution or results of the Contractor. The Contractor's failure to observe or report any deficiencies constitutes an acceptance of the Owner's other contractors work as suitable for the interface of the Contractor's work, except for latent deficiencies in the Owner's other contractors work.
- 19.3 Similarly, the Contractor shall promptly report to the Consultant and Owner any apparent deficiencies in their own work that would impact the proper execution or results of the Owner's other contractors.
- 19.4 The Contractor shall report to the Consultant and Owner any conflicts or claims for damages with the Owner's other contractors and settle such conflicts or claims for damages by mutual agreement or arbitration, if necessary, at no expense to the Owner.
- 19.5 In the event the Owner's other contractors sue the Owner regarding any damage alleged to have been caused by the Contractor, the Owner shall notify the Contractor, who shall defend such proceedings at the Contractor's expense. The Contractor shall pay or satisfy any judgment that may arise against the Owner, and pay all other costs incurred.

00 72 13
General Conditions

20. Subcontracts

- 20.1 The Contractor shall not subcontract any part of this contract without the written permission of the Owner.
- 20.2 The Contractor shall submit a complete list of named Subcontractors and material suppliers to the Consultant and Owner for approval by the Owner prior to commencing work. The Subcontractors named shall be reputable companies of recognized standing with a record of satisfactory work.
- 20.3 The Contractor shall not employ any Subcontractor or use any material until they have been approved, or where there is reason to believe the resulting work will not comply with the Contract Documents.
- 20.4 The Contractor, not the Owner, is as fully responsible for the acts and omissions of Subcontractors and of persons employed by them, as the Contractor is for the acts and omissions of persons directly or indirectly employed by the Contractor.
- 20.5 Neither the Contract Documents nor any Contractor-Subcontractor contract shall indicate, infer or create any direct contractual relationship between any Subcontractor and the Owner.

21. Contractor-Subcontractor Relationship

- 21.1 The Contractor shall be bound to the Subcontractor by all the obligations in the Contract Documents that bind the Contractor to the Owner.
- 21.2 The Contractor shall pay the Subcontractor, in proportion to the dollar value of the work completed and requisitioned by the Subcontractor, the approved dollar amount allowed to the Contractor no more than seven days after receipt of payment from the Owner.
- 21.3 The Contractor shall pay the Subcontractor accordingly if the Contract Documents or the subcontract provide for earlier or larger payments than described in the provision above.
- 21.4 The Contractor shall pay the Subcontractor for completed and requisitioned subcontract work, less retainage, no more than seven days after receipt of payment from the Owner for the Contractor's approved Requisition for Payment, even if the Consultant fails to certify a portion of the Requisition for Payment for a cause not the fault of the Subcontractor.
- 21.5 The Contractor shall not make a claim for liquidated damages or penalty for delay in any amount in excess of amounts that are specified by the subcontract.
- 21.6 The Contractor shall not make a claim for services rendered or materials furnished by the Subcontractor unless written notice is given by the Contractor to the Subcontractor within ten calendar days of the day in which the claim originated.
- 21.7 The Contractor shall give the Subcontractor an opportunity to present and to submit evidence in any progress conference or disputes involving subcontract work.

00 72 13
General Conditions

- 21.8 The Contractor shall pay the Subcontractor a just share of any fire insurance payment received by the Contractor.
- 21.9 The Subcontractor shall be bound to the Contractor by the terms of the Contract Documents and assumes toward the Contractor all the obligations and responsibilities that the Contractor, by those documents, assumes toward the Owner.
- 21.10 The Subcontractor shall submit applications for payment to the Contractor in such reasonable time as to enable the Contractor to apply for payment as specified.
- 21.11 The Subcontractor shall make any claims for extra cost, extensions of time or damages, to the Contractor in the manner provided in these General Conditions for like claims by the Contractor to the Owner, except that the time for the Subcontractor to make claims for extra cost is seven calendar days after the receipt of Consultant's instructions.

22. Supervision of the Work

- 22.1 During all stages of the Work the Contractor shall have a competent superintendent, with any necessary assistant superintendents, overseeing the project. The superintendent shall not be reassigned without the consent of the Owner unless a superintendent ceases to be employed by the Contractor due to unsatisfactory performance.
- 22.2 The superintendent represents the Contractor on the jobsite. Directives given by the Consultant or Owner to the superintendent shall be as binding as if given directly to the Contractor's main office. All important directives shall be confirmed in writing to the Contractor. The Consultant and Owner are not responsible for the acts or omissions of the superintendent or assistant superintendents.
- 22.3 The Contractor shall provide supervision of the Work equal to the industry's highest standard of care. The superintendent shall carefully study and compare all Contract Documents and promptly report any error, inconsistency or omission discovered to the Consultant. The Contractor may not necessarily be held liable for damages resulting directly from any error, inconsistency or omission in the Contract Documents or other instructions by the Consultant that was not revealed by the superintendent in a timely way.

23. Observation of the Work

- 23.1 The Contractor shall allow the Owner, the Consultant and the Bureau continuous access to the site for the purpose of observation of the progress of the work. All necessary safeguards and accommodations for such observations shall be provided by the Contractor.
- 23.2 The Contractor shall coordinate all required testing, approval or demonstration of the Work. The Contractor shall give sufficient notice to the appropriate parties of readiness for testing, inspection or examination.
- 23.3 The Contractor shall schedule inspections and obtain all required certificates of inspection for inspections by a party other than the Consultant.

00 72 13
General Conditions

- 23.4 The Consultant shall make all scheduled observations promptly, prior to the work being concealed or buried by the Contractor. If approval of the Work is required of the Consultant, the Contractor shall notify the Consultant of the construction schedule in this regard. Work concealed or buried prior to the Consultant's approval may need to be uncovered at the Contractor's expense.
- 23.5 The Consultant may order reexamination of questioned work, and, if so ordered, the work must be uncovered by the Contractor. If the work is found to conform to the Contract Documents, the Owner shall pay the expense of the reexamination and remedial work. If the work is found to not conform to the Contract Documents, the Contractor shall pay the expense, unless the defect in the work was caused by the Owner's Contractor, whose responsibility the reexamination expense becomes.
- 23.6 The Bureau shall periodically observe the Work during the course of construction and make recommendations to the Contractor or Consultant as necessary. Such recommendations shall be considered and implemented through the usual means for changes to the Work.
24. Consultant's Status
- 24.1 The Consultant represents the Owner during the construction period, and observes the work in progress on behalf of the Owner. The Consultant has authority to act on behalf of the Owner only to the extent expressly provided by the Contract Documents or otherwise demonstrated to the Contractor. The Consultant has authority to stop the work whenever such an action is necessary, in the Consultant's reasonable opinion, to ensure the proper execution of the contract.
- 24.2 The Consultant is the interpreter of the conditions of the contract and the judge of its performance. The Consultant shall favor neither the Owner nor the Contractor, but shall use the Consultant's powers under the contract to enforce faithful performance by both parties.
- 24.3 In the event of the termination of the Consultant's employment on the project prior to completion of the work, the Owner shall appoint a capable and reputable replacement. The status of the new Consultant relative to this contract shall be that of the former Consultant.
25. Management of the Premises
- 25.1 The Contractor shall place equipment and materials, and conduct activities on the premises in a manner that does not unreasonably hinder site circulation, environmental stability, or any long term effect. Likewise, the Consultant's directions shall not cause the use of premises to be impeded for the Contractor or Owner.
- 25.2 The Contractor shall not use the premises for any purpose other than that which is directly related to the scope of work. The Owner shall not use the premises for any purpose incompatible with the proposed work simultaneous to the work of the Contractor.
- 25.3 The Contractor shall enforce the Consultant's instructions regarding information posted on the premises such as signage and advertisements, as well as activities conducted on the premises such as fires, and smoking.

00 72 13
General Conditions

- 25.4 The Owner may occupy any part of the Project that is completed with the written consent of the Contractor, and without prejudice to any of the rights of the Owner or Contractor. Such use or occupancy shall not, in and of itself, be construed as a final acceptance of any work or materials.
26. Safety and Security of the Premises
- 26.1 The Contractor shall designate, and make known to the Consultant and the Owner, a safety officer whose duty is the prevention of accidents on the site.
- 26.2 The Contractor shall continuously maintain security on the premises and protect from unreasonable occasion of injury all people authorized to be on the job site. The Contractor shall also effectively protect the property and adjacent properties from damage or loss.
- 26.3 The Contractor shall take all necessary precautions to ensure the safety of workers and others on and adjacent to the site, abiding by applicable local, state and federal safety regulations. The Contractor shall erect and continuously maintain safeguards for the protection of workers and others, and shall post signs and other warnings regarding hazards associated with the construction process, such as protruding fasteners, moving equipment, trenches and holes, scaffolding, window, door or stair openings, and falling materials.
- 26.4 The Contractor shall restore the premises to conditions that existed prior to the start of the project at areas not intended to be altered according to the Contract Documents.
- 26.5 The Contractor shall protect existing utilities and exercise care working in the vicinity of utilities shown in the Drawings and Specifications or otherwise located by the Contractor.
- 26.6 The Contractor shall protect from damage existing trees and other significant plantings and landscape features of the site which will remain a permanent part of the site. If necessary or indicated in the Contract Documents, tree trunks shall be boxed and barriers erected to prevent damage to tree branches or roots.
- 26.7 The Contractor shall repair or replace damage to the Work caused by the Contractor's or Subcontractor's forces, including that which is reasonably protected, at the expense of the responsible party.
- 26.8 The Contractor shall not load, or allow to be loaded, any part of the Project with a force which imperils personal or structural safety. The Consultant may consult with the Contractor on such means and methods of construction, however, the ultimate responsibility lies with the Contractor.
- 26.9 The Contractor shall not jeopardize any work in place with subsequent construction activities such as blasting, drilling, excavating, cutting, patching or altering work. The Consultant must approve altering any structural components of the project. The Contractor shall supervise all construction activities carried out by others on site to ensure that the work is neatly done and in a manner that will not endanger the structure or the component parts.
- 26.10 The Contractor may act with their sole discretion in emergency situations that potentially effect health, life or serious damage to the premises or adjacent properties, to prevent such potential loss or injury. The Contractor may negotiate with the Owner for compensation for expenses due to such emergency work.

00 72 13
General Conditions

- 26.11 The Contractor and Subcontractors shall have no responsibility for the identification, discovery, presence, handling, removal or disposal of, or exposure of persons to, hazardous materials in any form at the project site. The Contractor shall avoid disruption of any hazardous materials or toxic substances at the project site and promptly notify the Owner in writing on the occasion of such a discovery.
- 26.12 The Contractor shall keep the premises free of any unsafe accumulation of waste materials caused by the work. The Contractor shall regularly keep the spaces "broom clean". See the Close-out of the Work provisions of this section regarding cleaning at the completion of the project.

27. Changes in the Work

- 27.1 The Contractor shall not proceed with extra work without an approved Change Order or Construction Change Directive. A Change Order which has been properly signed by all parties shall become a part of the contract.
- 27.2 A Change Order is the usual document for directing changes in the Work. In certain circumstances, however, the Owner may utilize a Construction Change Directive to direct the Contractor to perform changes in the Work that are generally consistent with the scope of the project. The Owner shall use a Construction Change Directive only when the normal process for approving changes to the Work has failed to the detriment of the Project, or when agreement on the terms of a Change Order cannot be met, or when an urgent situation requires, in the Owner's judgment, prompt action by the Contractor.
- 27.3 The Consultant shall prepare the Construction Change Directive representing a complete scope of work, with proposed Contract Price and Contract Time revisions, if any, clearly stated.
- 27.4 The Contractor shall promptly carry out a Construction Change Directive which has been signed by the Owner and the Consultant. Work thus completed by the Contractor constitutes the basis for a Change Order. Changes in the Contract Price and Contract Time shall be as defined in the Construction Change Directive unless subsequently negotiated with some other terms.
- 27.5 The method of determining the dollar value of extra work shall be by:
- .1 an estimate of the Contractor accepted by Owner as a lump sum, or
 - .2 unit prices named in the contract or subsequently agreed upon, or
 - .3 cost plus a designated percentage, or
 - .4 cost plus a fixed fee.
- 27.6 The Contractor shall determine the dollar value of the extra work for both the lump sum and cost plus designated percentage methods so as not to exceed the following rates. The rates include all overhead and profit expenses.
- .1 Contractor - for any work performed by the Contractor's own forces, up to 20% of the cost;
 - .2 Subcontractor - for work performed by Subcontractor's own forces, up to 20% of the cost;
 - .3 Contractor - for work performed by Contractor's Subcontractor, up to 10% of the amount due the Subcontractor.
- 27.7 The Contractor shall keep and provide records as needed or directed for the cost plus designated percentage method. The Consultant shall review and certify the appropriate amount which

00 72 13
General Conditions

- includes the Contractor's overhead and profit. The Owner shall make payments based on the Consultant's certificate.
- 27.8 Cost reflected in Change Orders shall be limited to the following: cost of materials, cost of delivery, cost of labor (including Social Security, pension, Workers' Compensation insurance, and unemployment insurance), and cost of rental of power tools and equipment. Labor cost may include a pro-ratio share of a foreman's time only in the case of an extension of contract time granted due to the Change Order.
- 27.9 Overhead reflected in Change Orders shall be limited to the following: bond premium, supervision, wages of clerks, time keepers, and watchmen, small tools, incidental expenses, general office expenses, and all other overhead expenses directly related to the Change Order.
- 27.10 The Contractor shall provide credit to the Owner for labor, materials, equipment and other costs but not overhead and profit expenses for those Change Order items that result in a net value of credit to the contract.
- 27.11 The Owner may change the scope of work of the Project without invalidating the contract. The Owner shall notify the Contractor of a change of the scope of work for the Owner's Contractors, which may affect the work of this Contractor, without invalidating the contract. Change Orders for extension of the time caused by such changes shall be developed at the time of directing the change in scope of work.
- 27.12 The Consultant may order minor changes in the Work, not involving extra cost, which is consistent with the intent of the design or project.
- 27.13 The Contractor shall immediately give written notification to the Consultant of latent conditions discovered at the site which materially differ from those represented in the Drawings or Specifications, and which may eventually result in a change in the scope of work. The Contractor shall suspend work until receiving direction from the Consultant. The Consultant shall promptly investigate the conditions and respond to the Contractor's notice with direction that avoids any unnecessary delay of the Work. The Consultant shall determine if the discovered conditions warrant a Change Order.
- 27.14 The Contractor shall, within ten calendar days of receipt of the information, give written notification to the Consultant if the Contractor claims that instructions by the Consultant will constitute extra cost not accounted for by Change Order or otherwise under the contract. The Consultant shall promptly respond to the Contractor's notice with direction that avoids any unnecessary delay of the Work. The Consultant shall determine if the Contractor's claim warrants a Change Order.
28. Correction of the Work
- 28.1 The Contractor shall promptly remove from the premises all work the Consultant declares is non-conforming to the contract. The Contractor shall replace the work properly at no expense to the Owner. The Contractor is also responsible for the expenses of others whose work was damaged or destroyed by such remedial work.

00 72 13
General Conditions

- 28.2 The Owner may elect to remove non-conforming work if it is not removed by the Contractor within a reasonable time, that time defined in a written notice from the Consultant. The Owner may elect to store removed non-conforming work not removed by the Contractor at the Contractor's expense. The Owner may, with ten days written notice, dispose of materials which the Contractor does not remove. The Owner may sell the materials and apply the net proceeds, after deducting all expenses, to the costs that should have been borne by the Contractor.
- 28.3 The Contractor shall remedy any defects due to faulty materials or workmanship and pay for any related damage to other work which appears within a period of one year from the date of substantial completion, and in accord with the terms of any guarantees provided in the contract. The Owner shall promptly give notice of observed defects to the Contractor and Consultant. The Consultant shall determine the status of all claimed defects. The Contractor shall perform all remedial work without unjustifiable delay in either the initial response or the corrective action.
- 28.4 The Consultant may authorize, after a reasonable notification to the Contractor, an equitable deduction from the contract amount in lieu of the Contractor correcting non-conforming or defective work.
29. Owner's Right to do Work
- 29.1 The Owner may, using other contractors, correct deficiencies attributable to the Contractor, or complete unfinished work. Such action shall take place only after giving the Contractor three days written notice, and provided the Consultant approves of the proposed course of action as an appropriate remedy. The Owner may then deduct the cost of the remedial work from the amount due the Contractor.
- 29.2 The Owner may act with their sole discretion when the Contractor is unable to take action in emergency situations that potentially effect health, life or serious damage to the premises or adjacent properties, to prevent such potential loss or injury. The Owner shall inform the Contractor of the emergency work performed, particularly where it may affect the work of the Contractor.
30. Termination of Contract and Stop Work Action
- 30.1 The Owner may, owing to a certificate of the Consultant indicating that sufficient cause exists to justify such action, without prejudice to any other right or remedy and after giving the Contractor and the Contractor's surety seven days written notice, terminate the employment of the Contractor. At that time the Owner may take possession of the premises and of all materials,

00 72 13
General Conditions

tools and appliances on the premises and finish the work by whatever method the Owner may deem expedient. Cause for such action by the Owner includes:

- .1 the contractor is adjudged bankrupt, or makes a general assignment for the benefit of its creditors, or
- .2 a receiver is appointed due to the Contractor's insolvency, or
- .3 the Contractor persistently or repeatedly refuses or fails to provide enough properly skilled workers or proper materials, or
- .4 the Contractor fails to make prompt payment to Subcontractors or suppliers of materials or labor, or
- .5 the Contractor persistently disregards laws, ordinances or the instructions of the Consultant, or is otherwise found guilty of a substantial violation of a provision of the Contract Documents.

- 30.2 The Contractor is not entitled, as a consequence of the termination of the employment of the Contractor as described above, to receive any further payment until the Work is finished. If the unpaid balance of the contract amount exceeds the expense of finishing the Work, including compensation for additional architectural, managerial and administrative services, such balance shall be paid to the Contractor. If the expense of finishing the Work exceeds the unpaid balance, the Contractor shall pay the difference to the Owner. The Consultant shall certify the expense incurred by the Contractor's default. This obligation for payment shall continue to exist after termination of the contract.
- 30.3 The Contractor may, if the Work is stopped by order of any court or other public authority for a period of thirty consecutive days, and through no act or fault of the Contractor or of anyone employed by the Contractor, with seven days written notice to the Owner and the Consultant, terminate this contract. The Contractor may then recover from the Owner payment for all work executed, any proven loss and reasonable profit and damage.
- 30.4 The Contractor may, if the Consultant fails to issue a certificate for payment within seven days after the Contractor's formal request for payment, through no fault of the Contractor, or if the Owner fails to pay to the Contractor within 30 days after submission of any sum certified by the Consultant, with seven days written notice to the Owner and the Consultant, stop the Work or terminate this Contract.

31. Delays and Extension of Time

- 31.1 The completion date of the contract shall be extended if the work is delayed by changes ordered in the work which have approved time extensions, or by an act or neglect of the Owner, the Consultant, or the Owner's Contractor, or by strikes, lockouts, fire, flooding, unusual delay in transportation, unavoidable casualties, or by other causes beyond the Contractor's control. The Consultant shall determine the status of all claimed causes.
- 31.2 The contract shall not be extended for delay occurring more than seven calendar days before the Contractor's claim made in writing to the Consultant. In case of a continuing cause of delay, only one claim is necessary.
- 31.3 The contract shall not be extended due to failure of the Consultant to furnish drawings if no schedule or agreement is made between the Contractor and the Consultant indicating the dates

00 72 13
General Conditions

which drawings shall be furnished and fourteen calendar days has passed after said date for such drawings.

31.4 This article does not exclude the recovery of damages for delay by either party under other provisions in the Contract Document.

32. Payments to the Contractor

- 32.1 As noted under *Preconstruction Conference* in this section, the Contractor shall submit a Schedule of Values form, before the first application for payment, for approval by the Owner and Consultant. The Consultant may direct the Contractor to provide evidence that supports the correctness of the form. The approved Schedule of Values shall be used as a basis for payments.
- 32.2 The Contractor shall submit an application for each payment (“Requisition for Payment”) on a form approved by the Owner and Consultant. The Consultant may require receipts or other documents showing the Contractor's payments for materials and labor, including payments to Subcontractors.
- 32.3 The Contractor shall submit Requisitions for Payment as the work progresses not more frequently than once each month, unless the Owner approves a more frequent interval due to unusual circumstances. The Requisition for Payment is based on the proportionate quantities of the various classes of work completed or incorporated in the Work, in agreement with the actual progress of the Work and the dollar value indicated in the Schedule of Values.
- 32.4 The Consultant shall verify and certify each Requisition for Payment which appears to be complete and correct prior to payment being made by the Owner. The Consultant may certify an appropriate amount for materials not incorporated in the Work which have been delivered and suitably stored at the site. The Contractor shall submit bills of sale, insurance certificates, or other such documents that will adequately protect the Owner’s interests prior to payments being certified.
- 32.5 In the event any materials delivered but not yet incorporated in the Work have been included in a certified Requisition for Payment with payment made, and said materials thereafter are damaged, deteriorated or destroyed, or for any reason whatsoever become unsuitable or unavailable for use in the Work, the full amount previously allowed shall be deducted from subsequent payments unless the Contractor satisfactorily replaces said material.
- 32.6 The Contractor may request certification of an appropriate dollar amount for materials not incorporated in the Work which have been delivered and suitably stored away from the site. The Contractor shall submit bills of sale, insurance certificates, right-of-entry documents or other such documents that will adequately protect the Owner’s interests. The Consultant shall determine if the Contractor's documentation for the materials is complete and specifically designated for the Project. The Owner may allow certification of such payments.
- 32.7 Subcontractors may request, and shall receive from the Consultant, copies of approved Requisitions for Payment showing the amounts certified in the Schedule of Values.
- 32.8 Certified Requisitions for Payment, payments made to the Contractor, or partial or entire occupancy of the project by the Owner shall not constitute an acceptance of any work that does

00 72 13
General Conditions

not conform to the Contract Documents. The making and acceptance of the final payment constitutes a waiver of all claims by the Owner, other than those arising from unsettled liens, from faulty work or materials appearing within one year from final payment or from requirements of the Drawings and Specifications, and of all claims by the Contractor, except those previously made and still unsettled.

33. Payments Withheld

- 33.1 The Owner shall retain five percent of each payment due the Contractor as part security for the fulfillment of the contract by the Contractor. The Owner may make payment of a portion of this “retainage” to the Contractor temporarily or permanently during the progress of the Work. The Owner may thereafter withhold further payments until the full amount of the five percent is reestablished. The Contractor may deposit with the Maine State Treasurer certain securities in place of retainage amounts due according to Maine Statute (5 M.R.S. §1746).
- 33.2 The Consultant may withhold or nullify the whole or a portion of any Requisitions for Payment submitted by the Contractor in the amount that may be necessary, in his reasonable opinion, to protect the Owner from loss due to any of the following:
- .1 defective work not remedied;
 - .2 claims filed or reasonable evidence indicating probable filing of claims;
 - .3 failure to make payments properly to Subcontractors or suppliers;
 - .4 a reasonable doubt that the contract can be completed for the balance then unpaid;
 - .5 liability for damage to another contractor.

The Owner shall make payment to the Contractor, in the amount withheld, when the above circumstances are removed.

34. Liens

- 34.1 The Contractor shall deliver to the Owner a complete release of all liens arising out of this contract before the final payment or any part of the retainage payment is released. The Contractor shall provide with the release of liens an affidavit asserting each release includes all labor and materials for which a lien could be filed. Alternately, the Contractor, in the event any Subcontractor or supplier refuses to furnish a release of lien in full, may furnish a bond satisfactory to the Owner, to indemnify the Owner against any lien.
- 34.2 In the event any lien remains unsatisfied after all payments to the Contractor are made by the Owner, the Contractor shall refund to the Owner all money that the latter may be compelled to pay in discharging such lien, including all cost and reasonable attorney’s fees.

35. Workmanship

- 35.1 The Contractor shall provide materials, equipment, and installed work equal to or better than the quality specified in the Contract Documents and approved in submittal and sample. The installation methods shall be of the highest standards, and the best obtainable from the respective trades. The Consultant’s decision on the quality of work shall be final.

00 72 13
General Conditions

- 35.2 The Contractor shall know local labor conditions for skilled and unskilled labor in order to apply the labor appropriately to the Work. All labor shall be performed by individuals well skilled in their respective trades.
- 35.3 The Contractor shall perform all cutting, fitting, patching and placing of work in such a manner to allow subsequent work to fit properly, whether that be by the Contractor, the Owner's Contractors or others. The Owner and Consultant may advise the Contractor regarding such subsequent work. Notwithstanding the notification or knowledge of such subsequent work, the Contractor may be directed to comply with this standard of compatible construction by the Consultant at the Contractor's expense.
- 35.4 The Contractor shall request clarification or revision of any design work by the Consultant, prior to commencing that work, in a circumstance where the Contractor believes the work cannot feasibly be completed at the highest quality, or as indicated in the Contract Documents. The Consultant shall respond to such requests in a timely way, providing clarifying information, a feasible revision, or instruction allowing a reduced quality of work. The Contractor shall follow the direction of the Consultant regarding the required request for information.
- 35.5 The Contractor shall guarantee the Work against any defects in workmanship and materials for a period of one year commencing with the date of the Certificate of Substantial Completion, unless specified otherwise for specific elements of the project. The Work may also be subdivided in mutually agreed upon components, each defined by a separate Certificate of Substantial Completion.
36. Close-out of the Work
- 36.1 The Contractor shall remove from the premises all waste materials caused by the work. The Contractor shall make the spaces "broom clean" unless a more thorough cleaning is specified. The Contractor shall clean all windows and glass immediately prior to the final inspection, unless otherwise directed.
- 36.2 The Owner may conduct the cleaning of the premises where the Contractor, duly notified by the Consultant, fails to adequately complete the task. The expense of this cleaning may be deducted from the sum due to the Contractor.
- 36.3 The Contractor shall participate in all final inspections and acknowledge the documentation of unsatisfactory work, customarily called the "punch list", to be corrected by the Contractor. The Consultant shall document the successful completion of the Work in a dated Certificate of Substantial Completion, to be signed by Owner, Consultant, and Contractor.
- 36.4 The Contractor shall not call for final inspection of any portion of the Work that is not completely and permanently installed. The Contractor may be found liable for the expenses of individuals called to final inspection meetings prematurely.
- 36.5 The Contractor and all major Subcontractors shall participate in the end-of-warranty-period conference, typically scheduled close to one year after the Substantial Completion date.

**00 72 13
General Conditions**

37. Date of Completion and Liquidated Damages

- 37.1 The Contractor may make a written request to the Owner for an extension or reduction of time, if necessary. The request shall include the reasons the Contractor believes justifies the proposed completion date. The Owner may grant the revision of the contract completion date if the Work was delayed due to conditions beyond the control and the responsibility of the Contractor. The Contractor shall not conduct unauthorized accelerated work or file delay claims to recover alleged damages for unauthorized early completion.

- 37.2 The Contractor shall vigorously pursue the completion of the Work and notify the Owner of any factors that have, may, or will affect the approved Schedule of the Work. The Contractor may be found responsible for expenses of the Owner or Consultant if the Contractor fails to make notification of project delays.

- 37.3 The Project is planned to be done in an orderly fashion which allows for an iterative submittal review process, construction administration including minor changes in the Work and some bad weather. The Contractor shall not file delay claims to recover alleged damages on work the Consultant determines has followed the expected rate of progress.

- 37.4 The Consultant shall prepare the Certificate of Substantial Completion which, when signed by the Owner and the Contractor, documents the date of Substantial Completion of the Work or a designated portion of the Work. The Owner shall not consider the issuance of a Certificate of Occupancy by an outside authority a prerequisite for Substantial Completion if the Certificate of Occupancy cannot be obtained due to factors beyond the Contractor’s control.

- 37.5 Liquidated Damages may be deducted from the sum due to the Contractor for each calendar day that the Work remains uncompleted after the completion date specified in the Contract or an approved amended completion date. The dollar amount per day shall be calculated using the Schedule of Liquidated Damages table shown below.

If the original contract amount is:	The per day Liquidated Damages shall be:
Less than \$100,000	\$250
\$100,000 to less than \$2,000,000	\$750
\$2,000,000 to less than \$10,000,000	\$1,500
\$10,000,000 and greater	\$1,500 plus \$250 for each \$2,000,000 over \$10,000,000

38. Dispute Resolution

38.1 Mediation

- 38.1.1 A dispute between the parties which arises under this Contract which cannot be resolved through informal negotiation, shall be submitted to a neutral mediator jointly selected by the parties.

- 38.1.2 Either party may file suit before or during mediation if the party, in good faith, deems it to be necessary to avoid losing the right to sue due to a statute of limitations. If suit is filed before good faith mediation efforts are completed, the party filing suit shall agree to stay all proceedings in the lawsuit pending completion of the mediation process, provided such stay is without prejudice.

00 72 13
General Conditions

38.1.3 In any mediation between the Owner and the Consultant, the Owner has the right to consolidate related claims between Owner and Contractor.

38.2 Arbitration

38.2.1 If the dispute is not resolved through mediation, the dispute shall be settled by arbitration. The arbitration shall be conducted before a panel of three arbitrators. Each party shall select one arbitrator; the third arbitrator shall be appointed by the arbitrators selected by the parties. The arbitration shall be conducted in accordance with the Maine Uniform Arbitration Act (MUAA), except as otherwise provided in this section.

38.2.2 The decision of the arbitrators shall be final and binding upon all parties. The decision may be entered in court as provided in the MUAA.

38.2.3 The costs of the arbitration, including the arbitrators' fees shall be borne equally by the parties to the arbitration, unless the arbitrator orders otherwise.

38.2.4 In any arbitration between the Owner and the Consultant, the Owner has the right to consolidate related claims between Owner and Contractor.

00 73 46
Wage Determination Schedule

PART 1- GENERAL

1.1 Related Documents

- A. Drawings and general provisions of the Contract, including General and Supplementary Conditions and other Division 01 Specifications Sections, apply to this Section.

1.2 Summary

- A. This Section includes the wage determination requirements for Contractors as issued by the State of Maine Department of Labor Bureau of Labor Standards or the United States Department of Labor.

1.3 Requirements

- A. Conform to the wage determination schedule for this project which is shown on the following page.

PART 2 - PRODUCTS (not used)

PART 3 - EXECUTION (not used)

Note to Bidders: Wage Rates are required to be used for this project, but for 2024 are not yet issued as of 12/29/23. They will be issued by Addendum when available

SECTION 01010 – SUMMARY OF WORK

PART 1 - GENERAL

The work includes, the following major work items and any incidentals necessary.

A. SCOPE

1. Work items include the following plus related and incidental items required to make a complete and functional facility.
2. Provide one 40 foot by 16 foot float as shown on the plans and deliver to the Eagle Island landing pier. Coordinate delivery with the Owner and connect the new float to the existing mooring system under the direction of the Owner. All labor, materials, and equipment are supplied by the Contractor
3. There is no coating or paint in this project but markings and grade stamps, foot prints, dirt, etc shall be removed from the exposed surfaces of the deck tie rails and other exposed surfaces of the deck.
4. The Owner will inspect the completed float before transportation to the site. The Owner retains the right to require additional cleaning or replacement of any deck planks with visible defects such as loose knots, splits, warping, wane, or other defects.
5. It is the Owner's intent that the Contractor will construct the float at a suitable facility provided by the contractor on the mainland. There is no suitable location on Eagle Island.
6. The Contractor will transport the float to Eagle Island float where it will be anchored by the Contractor using the Owner's existing Seaflex mooring system, to the new fabricated steel assembly as shown as part of the float. The Contractor will provide all necessary boats, tugs, barges, etc to transport the float and crew.

B SCHEDULE AND COORDINATION

1. The facility is closed to the public during the winter season and the existing float will have been removed and brought to the mainland by others.
2. It is the Owner's intent that the new float be complete and installed at least two weeks prior to when the facility is opened for the summer season in June 2024.
3. Coordinate with the Owner's Representative and park staff on schedules and needs. The Owner's Representative for the project shall be kept informed of activities and schedule, and shall be responsible to coordinate with the Contractor.
4. Notify the Owner's Representative and the Engineer of questions or adjustments needed to the Contract Documents if found. Do not proceed until instructed by the Owner's Representative. Changes in the Contract shall be recorded whether or not affecting the price and schedule.

5. The Owner's Representative will direct the Contractor on items not shown in these plans, if any.

C. The lump Sum Payment will be full compensation for materials, equipment, labor, transportation, and mobilization expenses.

D. LUMBER

1. All lumber shall be Southern Pine, pressure treated., The grade of all timber shall be no. 2 or better, except the grade of decking, exposed skirt boards, and tie rails shall be no. 1 or Select. All lumber shall be surfaced four sides prior to treatment, except the main skid structural beams. The main skid beams shall be rough sawn but the top surface shall be dressed as required so that the resulting support for the joists is flat and true.
2. Submerged skid timbers, float drum supports, and deck joists shall be treated with CCA to 2.50 pcf retention, meeting AWPA UC5A.
3. The decking, tie rails and outside edge skirt members shall be treated with a non-CCA treatment, such as copper azole or micronized copper, to a retention level meeting AWPA UC4C.
4. During construction treat all cut surfaces and holes with AWPA approved copper based field solution.

E. FASTENERS AND HARDWARE

1. All hardware and fasteners shall be hot dipped galvanized or stainless steel.
2. Steel bolts, nuts and washers shall be ASTM A307 hot dipped galvanized.
3. Deck and Timber screws with alternative equivalent proprietary finishes equal to galvanizing may be used., subject to Owner approval.
4. All cleats shall be 15" galvanized cast steel, horn cleats, through bolted through decking and blocking. Provide 3/8 " galvanized steel thick backing plates for all cleats.
5. Fenders shall be 4' x 4" D-shaped rubber fenders with D-shaped bore, commercial grade suitable for marine fenders as approved by the Owner. supply in as long lengths as practical for each segment as shown. Bring into contact with adjacent fender at each corner
6. Provide Ace Rotomolded marine floats in the sizes shown.

F. STEEL FABRICATIONS

1. All Steel parts and components ASTM A36 or better. Welds E70XX.
2. Fabricated steel parts are to be cut, welded, ground and cleaned of all sharp edges and weld patten, then hot dipped galvanized after fabrication.

END OF SECTION

APPENDIX B Reference Documents

Float Drum Information

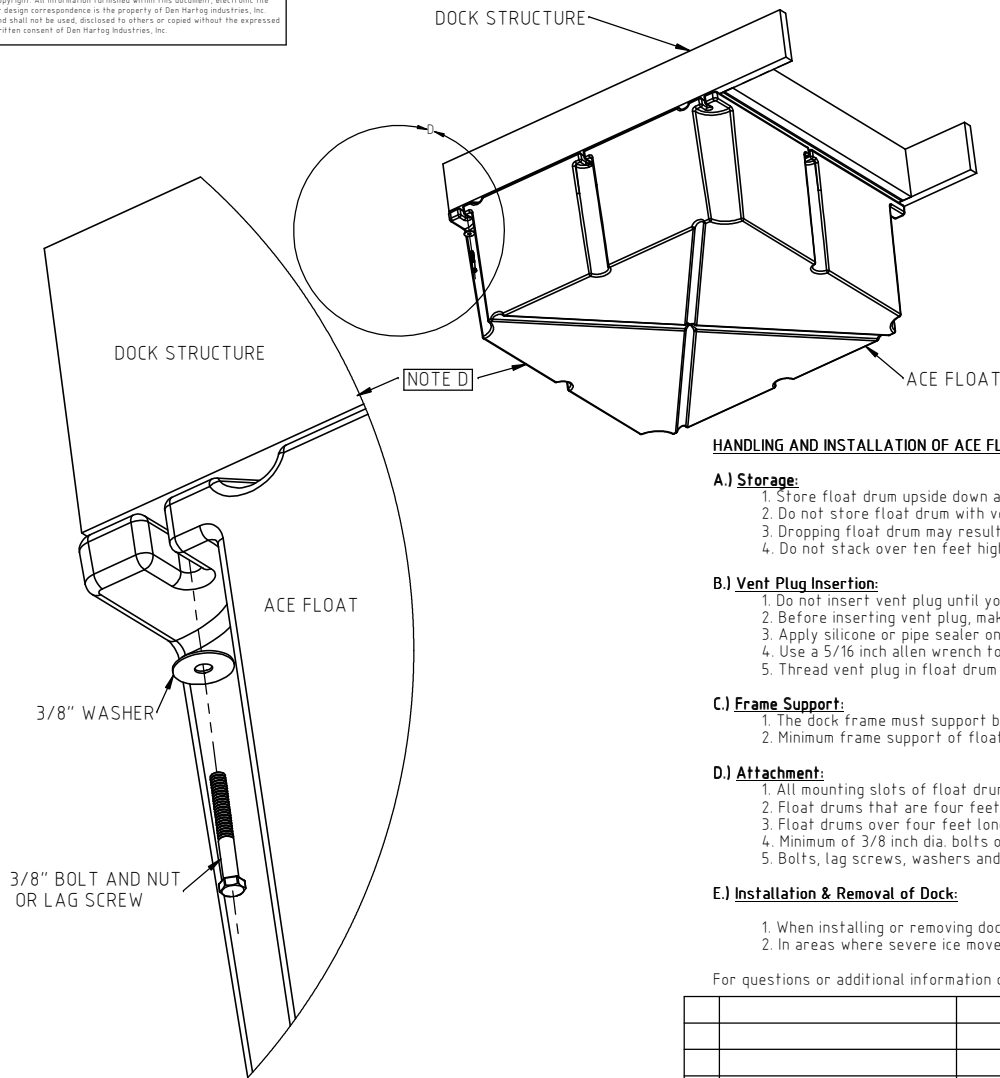

DETAIL D
SCALE 1 : 3

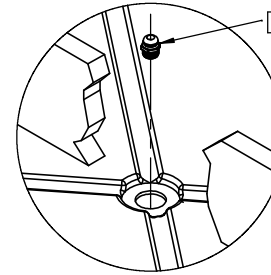

DETAIL B
SCALE 1 : 8

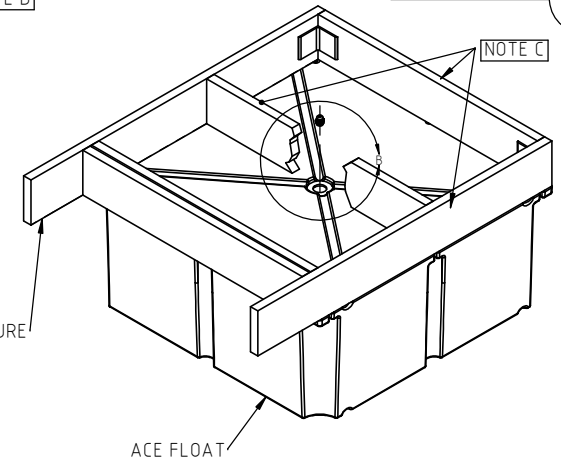

HANDLING AND INSTALLATION OF ACE FLOAT DRUMS

A.) Storage:

1. Store float drum upside down and off the ground with plug hole facing down.
2. Do not store float drum with vent plugs inserted in areas of direct sunlight or hot temperatures.
3. Dropping float drum may result in damage, especially in cold weather.
4. Do not stack over ten feet high.

B.) Vent Plug Insertion:

1. Do not insert vent plug until you are ready to use float drum.
2. Before inserting vent plug, make sure to drain the float drum of any water that might have seeped through the plug hole.
3. Apply silicone or pipe sealer on vent plug to keep the inside of the float drum waterproof.
4. Use a 5/16 inch allen wrench to insert vent plug.
5. Thread vent plug in float drum until the top of the plug is level with the top of the float drum.

C.) Frame Support:

1. The dock frame must support both sides and ends of float drum.
2. Minimum frame support of float drum must be every 48 x 48 or every sixteen square feet.

D.) Attachment:

1. All mounting slots of float drum must be bolted or lagged to the frame if dock is exposed to strong wave action.
2. Float drums that are four feet long (or less) must be attached to the frame by using at least four mounting slots.
3. Float drums over four feet long must be attached to the frame by using at least six mounting slots.
4. Minimum of 3/8 inch dia. bolts or lag screws with flat washers are required.
5. Bolts, lag screws, washers and lock nuts must be galvanized or stainless steel.

E.) Installation & Removal of Dock:

1. When installing or removing dock, lift the dock sections - do not slide! Sliding float drums may result in puncturing or wearing a hole in the wall of the float drum.
2. In areas where severe ice movement occurs, docks must be removed during winter months.

For questions or additional information on the use of the ACE Float Drums, please call 1-800-342-3408 or 712-752-8432 or contact us at www.acefloatdrums.com

				DRAWN / DATE ADH 1/10/12	MATERIAL	 <p>Den Hartog INDUSTRIES, INC. <small>ACE Float Drum Injection Molding - Wire Molding - Stamping</small> 4010 HOSPERS DRIVE S. BOX 425, HOSPERS, IOWA 51238-0421</p>
				APPROV / DATE REH 1/10/12		
REV	DESCRIPTION	BY / DATE	CCN	NOTES:		DESCRIPTION HANDLING AND INSTALLATION OF ACE ROTO-MOLD FLOAT DRUMS
ALL DIMENSIONS ARE IN DECIMAL INCHES TOLERANCES UNLESS OTHERWISE SPECIFIED		THIRD ANGLE PROJECTION ANSI 14.5M		SHOT WEIGHT:		SCALE N.S.
POLYETHYLENE		METAL		SHIPPING WEIGHT:		PART NO. 19526
±1% @ 68°F		DECIMAL = 125" FRACTIONS = 16" ANGLE ± 1°		FINISH:		

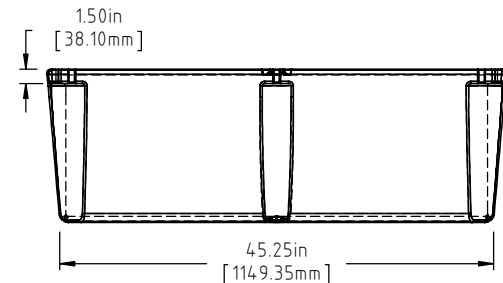
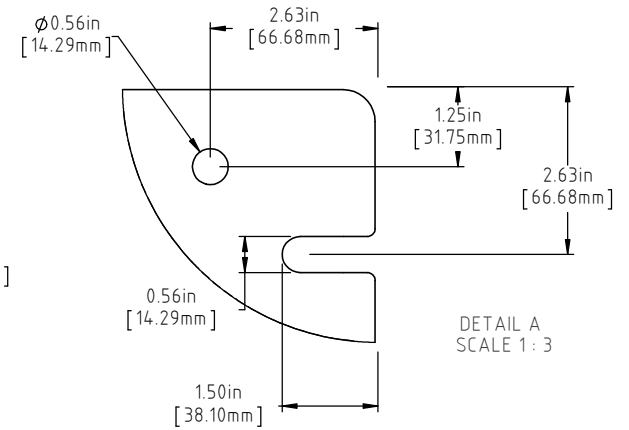
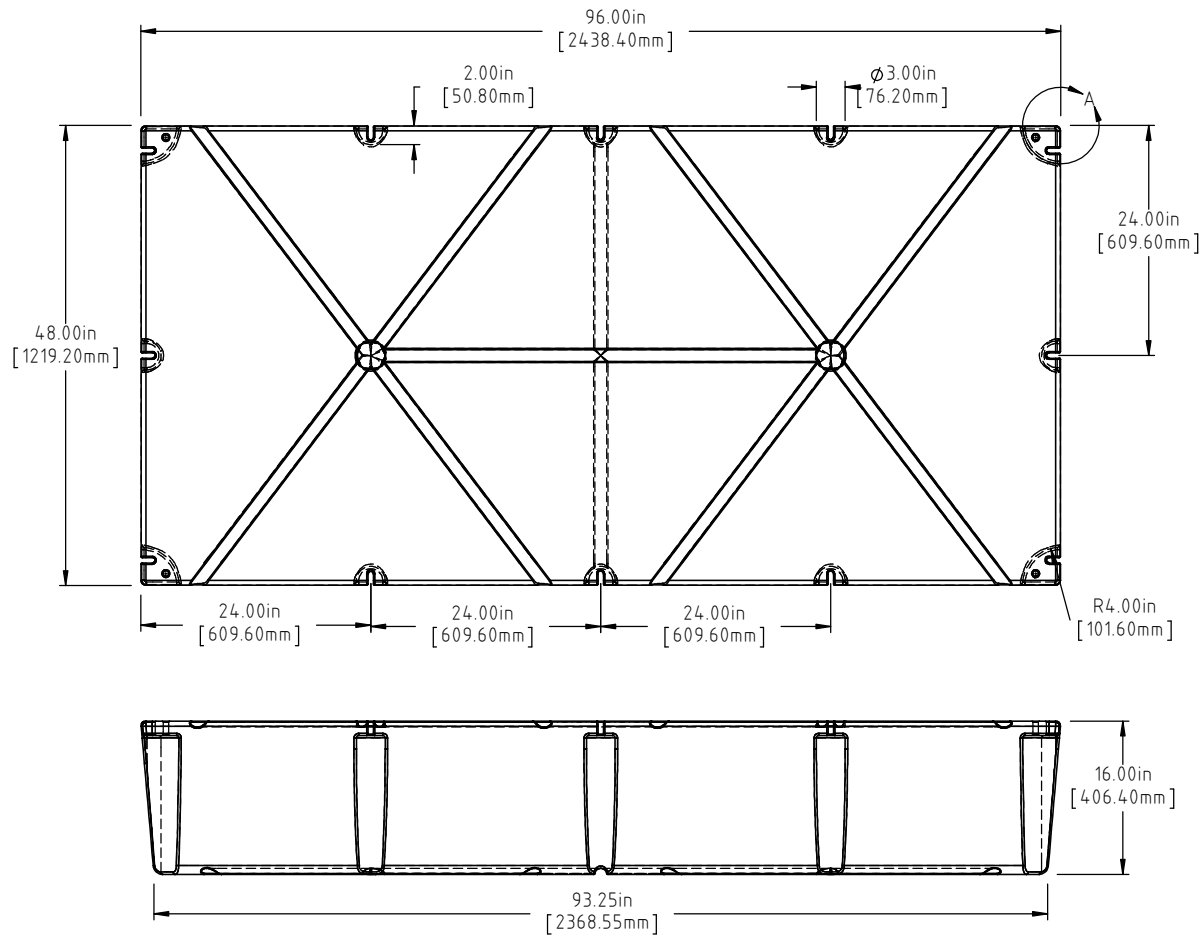

(A) (C)
 NOTE: BUOYANCY 2396.00 LBS.(1086.81 KG.)

C	131 LBS WAS 124 LBS, 2396 LBS WAS 2420 LBS	ADH 6/27/12	2420
B	METRIC DIMENSIONS ADDED	ADH 6/23/08	1685
A	ADD BUOYANCY NOTE	GWC 1/11/07	
A	CHANGE WEIGHT AF WAS 82 FF WAS 134	GWC 1/11/07	
1	CHANGE WEIGHT	11/17/94	
REV	DESCRIPTION	BY / DATE	CCN

DRAWN / DATE	MATERIAL
DEAN 11/17/94	POLYETHYLENE
APPRD. / DATE	
ADH 11/6/07	

ALL DIMENSIONS ARE IN DECIMAL INCHES
 TOLERANCES UNLESS OTHERWISE SPECIFIED
 POLYETHYLENE
 ±1% @ 68°F

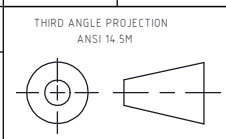

SHOT WEIGHT:
84 LBS.(38.10 KG.)
 SHIPPING WEIGHT:
SEE NOTES
 FINISH:

NOTES: (A) (C)
 1.) AF 84 LBS.(38.10 KG.)
 2.) FF 131 LBS.(59.42 KG)
 3.) 0.150in(3.81mm) NOM. WALL



Den Hartog
INDUSTRIES, INC.

Ace Roto-Mold Injection Molding Blow Molding Sowjoy

4010 HOSPERS DRIVE S. BOX 425, HOSPERS, IOWA 51238-0425

DESCRIPTION	48 X 96 X 16 FLOAT	
SCALE	N.S.	PART NO. 4896-16

© DEN HARTOG INDUSTRIES, INC.

Copyright. All information furnished within this document, electronic file or design correspondence is the property of Den Hartog Industries, Inc. and shall not be used, disclosed to others or copied without the expressed written consent of Den Hartog Industries, Inc.

3696-16

B

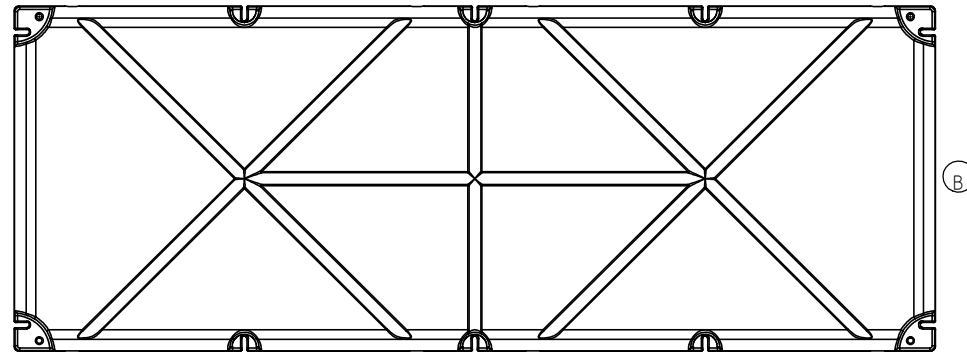
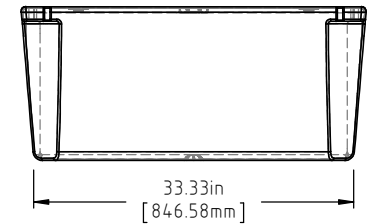
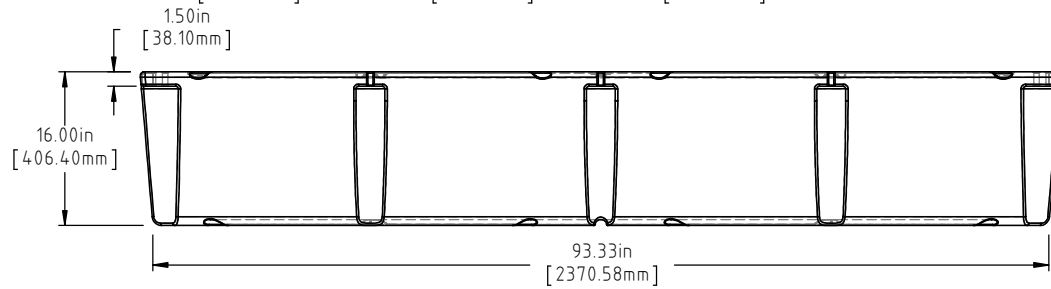
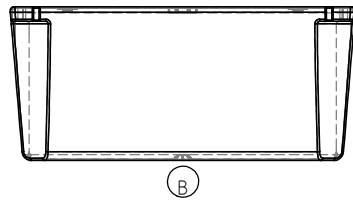
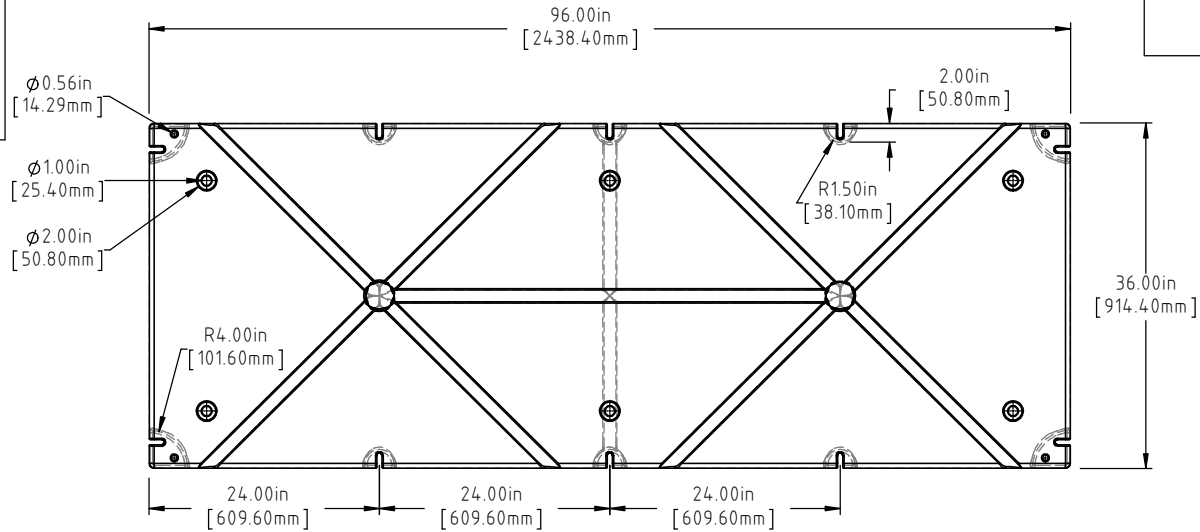

NOTE: BUOYANCY 1735.00 LBS.(786.98 KG.)

B	BOTTOM AND SIDE VIEWS ADDED TO PRINT	ADH 12/4/14	2971	DRAWN / DATE DHJ 1/9/06	MATERIAL POLYETHYLENE
A	103 LBS WAS 104, BUOYANCY NOTE ADDED	ADH 6/22/12	2420	APPRD. / DATE ADH 11/5/07	
REV	DESCRIPTION	BY / DATE	CCN		
ALL DIMENSIONS ARE IN DECIMAL INCHES TOLERANCES UNLESS OTHERWISE SPECIFIED		THIRD ANGLE PROJECTION ANSI 14.5M		SHOT WEIGHT: 72 LBS.(32.66 KG.)	NOTES: (A) 1.) AF 72 LBS.(32.66 KG.) 2.) FF 103 LBS.(46.72 KG.)
POLYETHYLENE ±1% @ 68°F		METAL DECIMAL ± .125" FRACTION ± 1/4" ANGLE ± 1°		SHIPPING WEIGHT: SEE NOTES	
		FINISH:			



Den Hartog
INDUSTRIES, INC.

Ace Roto-Mold Injection Molding Blow Molding Sowjoy

4010 HOSPERS DRIVE S. BOX 425, HOSPERS, IOWA 51238-0425

DESCRIPTION	36 X 96 X 16 FLOAT	
SCALE	N.S.	PART NO. 3696-16