

ACCESS AND CRANE ROAD DETAILS AND NOTES

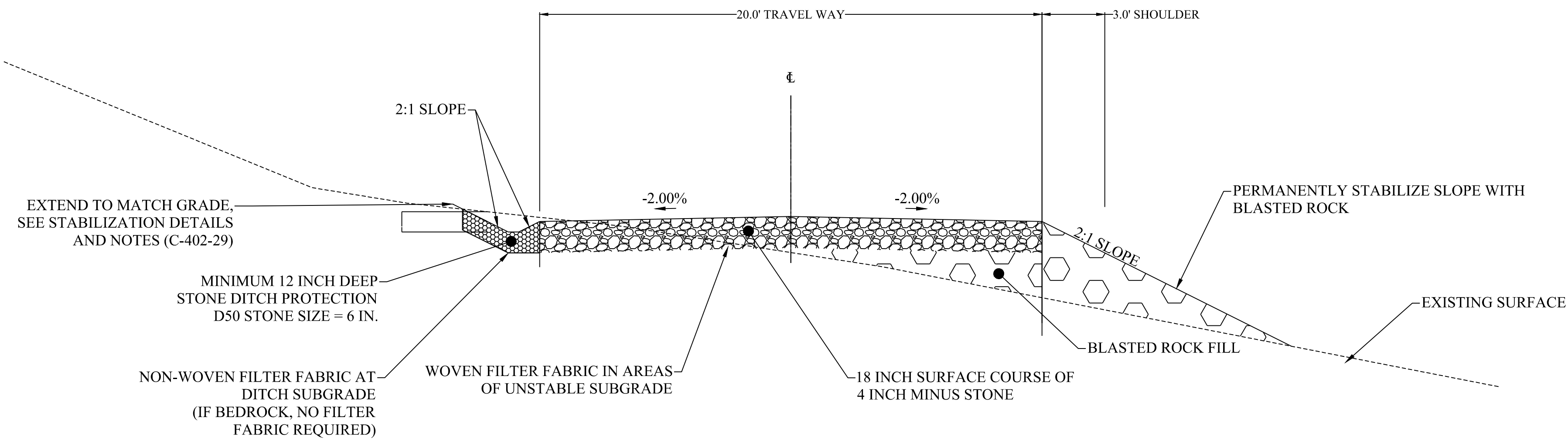

24 FT ACCESS ROAD CROSS SECTION DETAIL
NOT TO SCALE

- NOTES:
1. IN AREAS SHOWING A HIGH WATER TABLE, HIGH RUNOFF POTENTIAL, OR SUBSURFACE DRAINAGE FEATURES, ROCK SANDWICH AND ROCK MAKI SECTIONS SHOULD BE USED.
 2. SULFITIC ROCK AND ORE ROCK ARE NOT SUITABLE FOR USE IN ROAD SECTION.
 3. WOVEN FILTER FABRIC MUST HAVE A TENSILE STRENGTH OF 250 LBS AND A PUNCTURE STRENGTH OF 100 LBS. THE APPARENT OPENING SIZE MUST BE OF A U.S. STD. SIEVE NO. 40.
 4. NON-WOVEN FILTER FABRIC MUST HAVE A TENSILE STRENGTH OF 160 LBS AND A PUNCTURE STRENGTH OF 95 LBS. THE APPARENT OPENING SIZE MUST BE OF A U.S. STD. SIEVE NO. 70.
 5. INSPECTIONS BY A PROFESSIONAL ENGINEER WILL CONSIST OF A VISIT TO THE SITE PRIOR TO CONSTRUCTION TO CONSULT WITH THE EARTHWORK CONTRACTOR AND A POST CONSTRUCTION MEETING TO CONFIRM GRADING ON LOTS AND FOR ALL DRIVEWAYS/ROADS TO ENSURE RUNOFF IS DIRECTED ACCORDING TO PLANS AND TO OVERSEE THE RE-STABILIZATION OF THE LOT INTO A VEGETATED COVER.

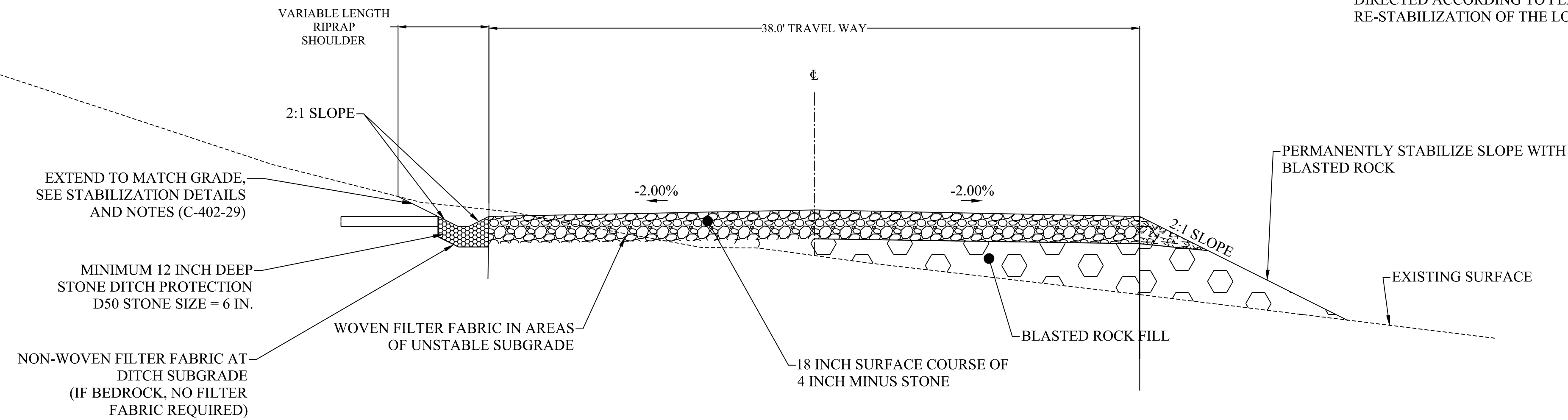

32 FT CRANE ROAD CROSS SECTION DETAIL
NOT TO SCALE

GENERAL NOTES:

1. SCALES NOTED ARE APPLICABLE TO FULL SIZE (24"x36") DRAWINGS ONLY. SCALE REDUCED DRAWINGS ACCORDINGLY.
2. NORTH AS SHOWN HEREON IS REFERENCED TO GRID NORTH, NAD83 MAINE STATE PLANES, WEST ZONE, US FOOT.
3. ELEVATIONS AS SHOWN HEREON ARE REFERENCED TO NAD 83.
4. EXISTING TOPOGRAPHIC AND PLANIMETRIC SURVEY INFORMATION AS SHOWN HEREON IS THE RESULT OF AERIAL TOPOGRAPHIC MAPPING COMPLETED BY PHOTOGRAMMETRIC TECHNOLOGY, INC. DEVELOPED FROM AERIAL PHOTOGRAPHY COMPLETED BY PHOTOGRAMMETRIC TECHNOLOGY, INC.
5. ENVIRONMENTAL RESOURCE MAPPING (WETLANDS, STREAMS, VERNAL POOLS, ETC.) AS SHOWN HEREON BY TETRA TECH.
6. INVERTS SHOWN ON PROPOSED CULVERTS MAY BE ADJUSTED BASED ON FIELD CONDITIONS.

No.	Revision/Issue	Date

PATRIOT RENEWABLES

EMS

ENGINEERING & MANAGEMENT SERVICES, INC.

540 SOUTH STREET, SUITE 100, WEST BURNFIELD, MA 01793
TEL: (877) 850-0000 FAX: (877) 850-0001

Stamp:

Drawing Title:

GENERAL NOTES AND LEGEND

Date:	05/25/2021	Scale:	AS SHOWN
Drawn By:	GAD	Chk'd By:	RSC
Project:	WESTERN MAINE RENEWABLE ENERGY PROJECT		
Address:	MOSCOW, ME		
Client:	WESTERN MAINE RENEWABLES		
Sheet Number:	51 OF 62		

Dwg No.: **C-401**

SLOPE STABILIZATION DETAILS AND NOTES

CUT SLOPE IN SOIL
NOT TO SCALE

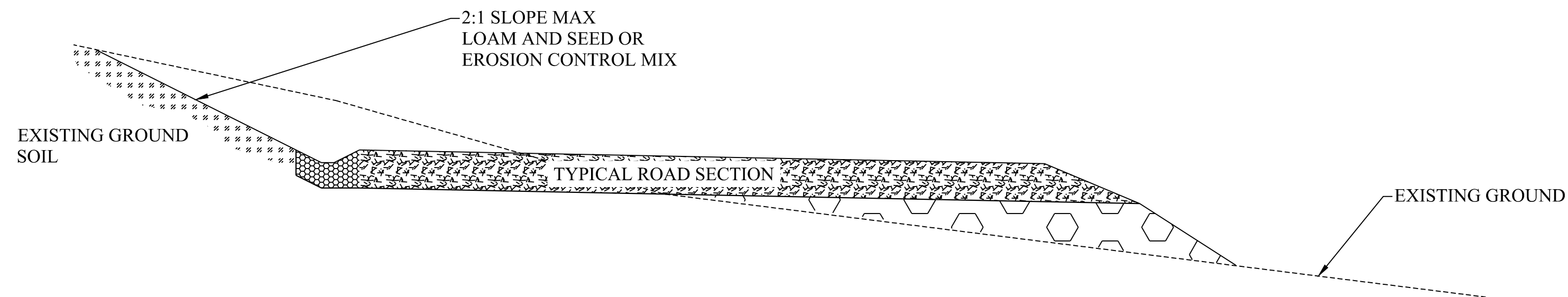

CUT SLOPE IN SOIL WITH HIGH WATER TABLE
NOT TO SCALE

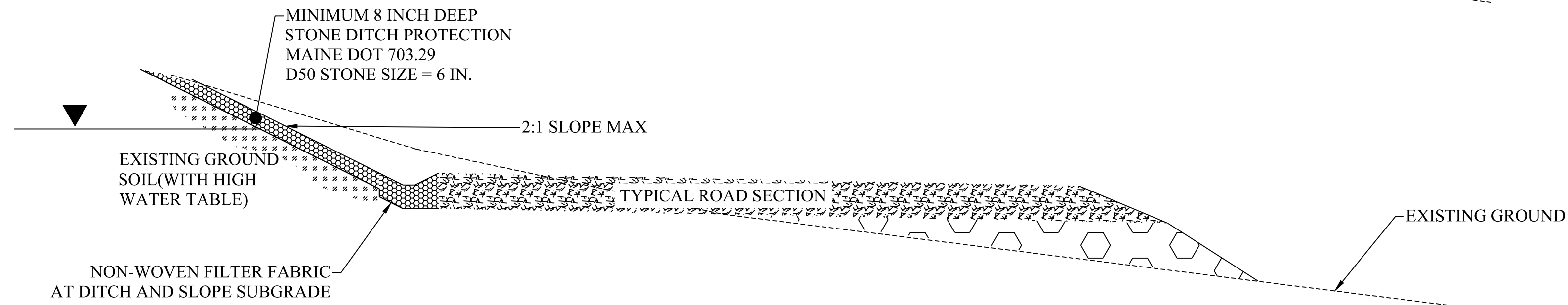

CUT SLOPE IN BEDROCK
NOT TO SCALE

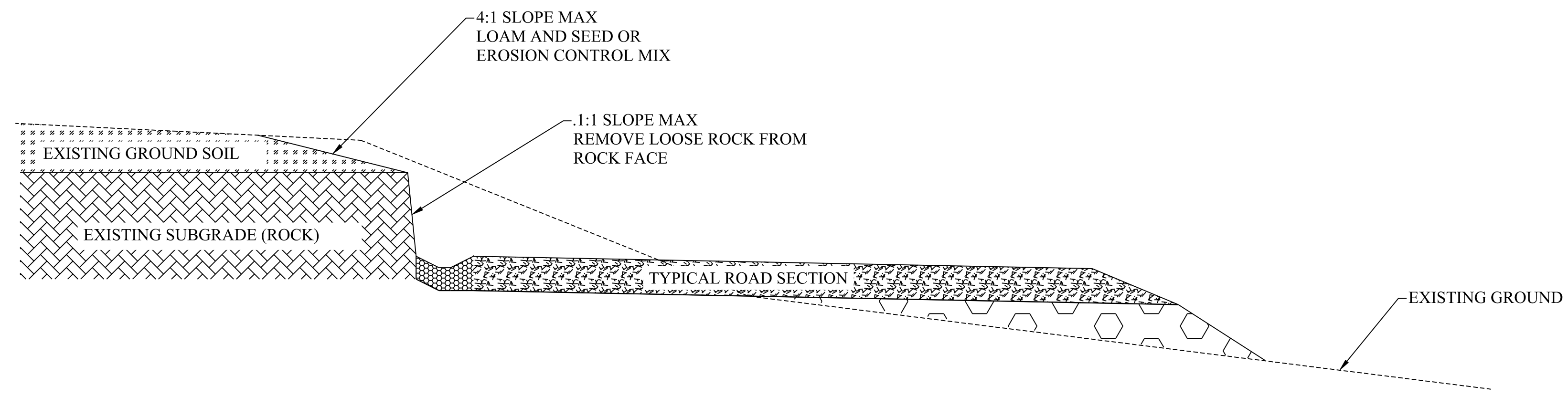

FILL SLOPE AT DOWNGRAIENT
NOT TO SCALE

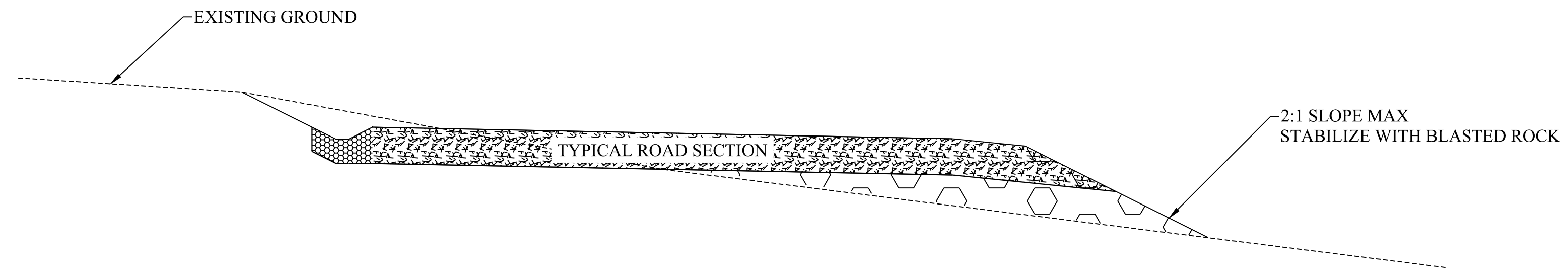

CUT SLOPE AT DOWNGRAIENT
NOT TO SCALE

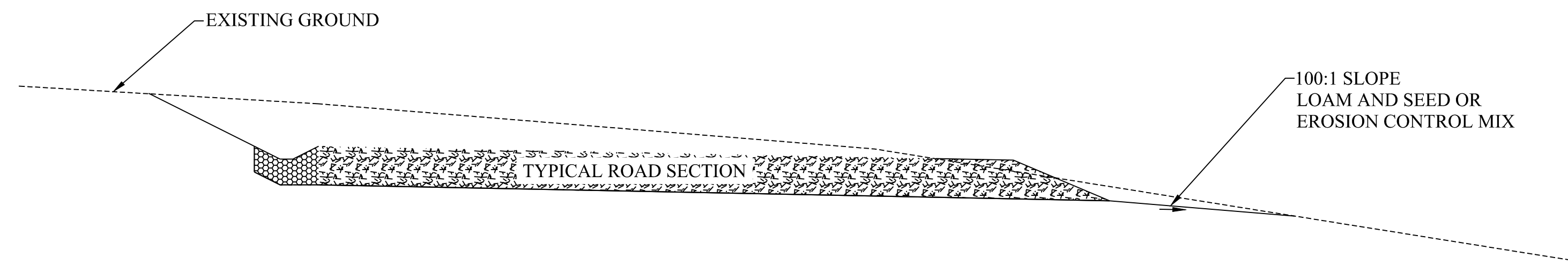

GENERAL NOTES:

1. SCALES NOTED ARE APPLICABLE TO FULL SIZE (24"x36") DRAWINGS ONLY. SCALE REDUCED DRAWINGS ACCORDINGLY.
2. NORTH AS SHOWN HEREON IS REFERENCED TO GRID NORTH, NAD83 MAINE STATE PLANES, WEST ZONE, US FOOT.
3. ELEVATIONS AS SHOWN HEREON ARE REFERENCED TO NAD 83.
4. EXISTING TOPOGRAPHIC AND PLANIMETRIC SURVEY INFORMATION AS SHOWN HEREON IS THE RESULT OF AERIAL TOPOGRAPHIC MAPPING COMPLETED BY PHOTOGRAMMETRIC TECHNOLOGY, INC. DEVELOPED FROM AERIAL PHOTOGRAPHY COMPLETED BY PHOTOGRAMMETRIC TECHNOLOGY, INC.
5. ENVIRONMENTAL RESOURCE MAPPING (WETLANDS, STREAMS, VERNAL POOLS, ETC.) AS SHOWN HEREON BY TETRA TECH.
6. INVERTS SHOWN ON PROPOSED CULVERTS MAY BE ADJUSTED BASED ON FIELD CONDITIONS.

No.	Revision/Issue	Date
-----	----------------	------

PATRIOT RENEWABLES

EMS
ENGINEERING & MANAGEMENT SERVICES, INC.
540 SOUTH STREET, SUITE 100, WESTPORT, MAINE 04092
TEL: (877) 850-0000 FAX: (877) 850-0000

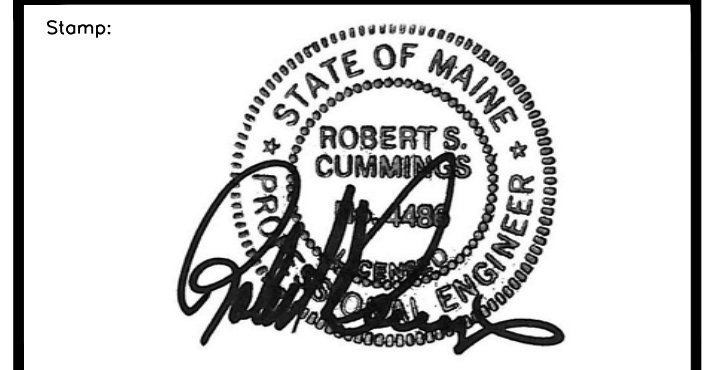

Drawing Title:
ACCESS AND CRANE ROAD CUT AND FILL SLOPE STABILIZATION DETAILS AND NOTES

Date:	05/25/2021	Scale:	AS SHOWN
Drawn By:	GAD	Chk'd By:	RSC
Project:	WESTERN MAINE RENEWABLE ENERGY PROJECT		
Address:	MOSCOW, ME		
Client:	WESTERN MAINE RENEWABLES		
Sheet Number:	52 OF 62		

Desig No.:
C-402

CULVERT AND LEVEL LIP SPREADER DETAIL/DITCH TURNOUT

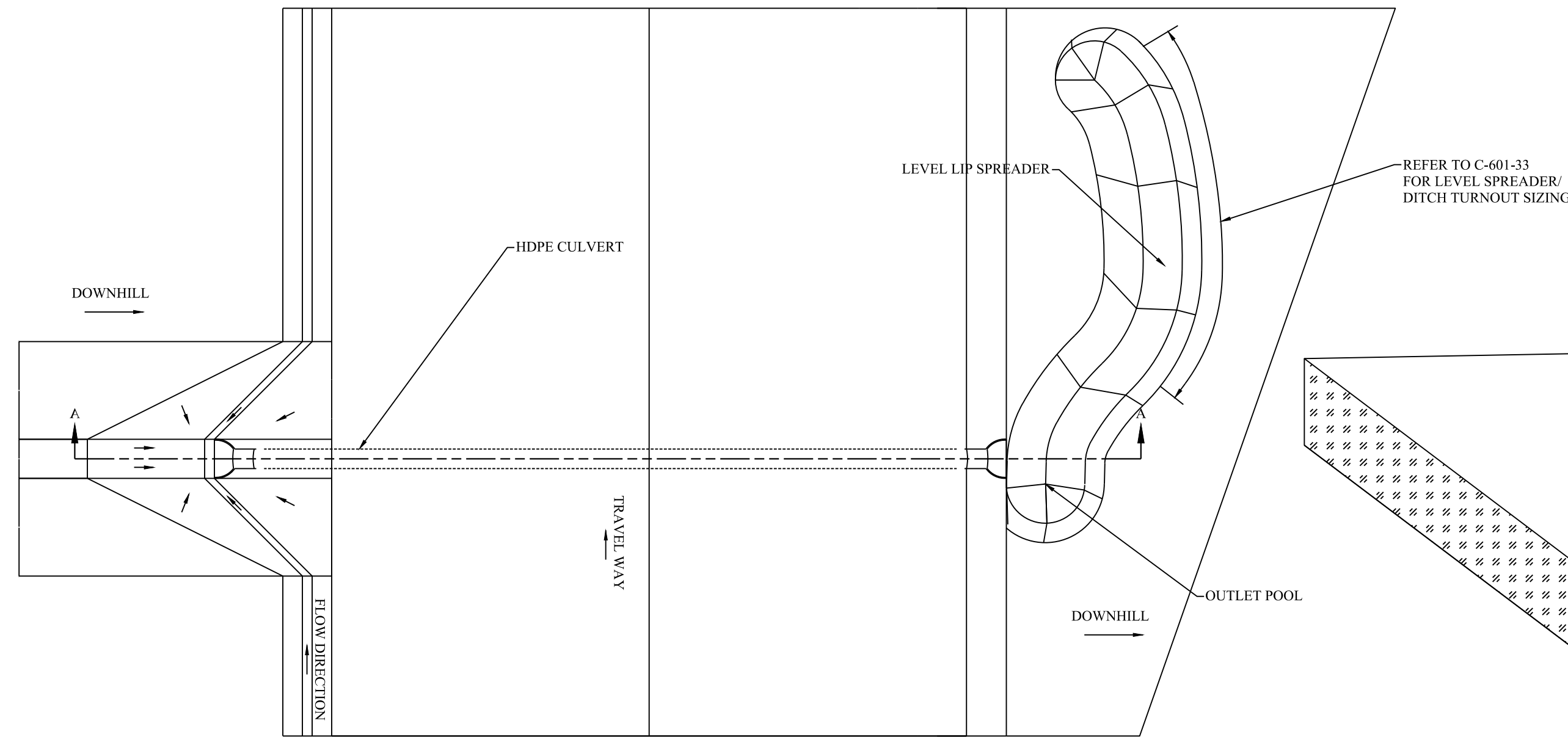

PLAN VIEW
NOT TO SCALE

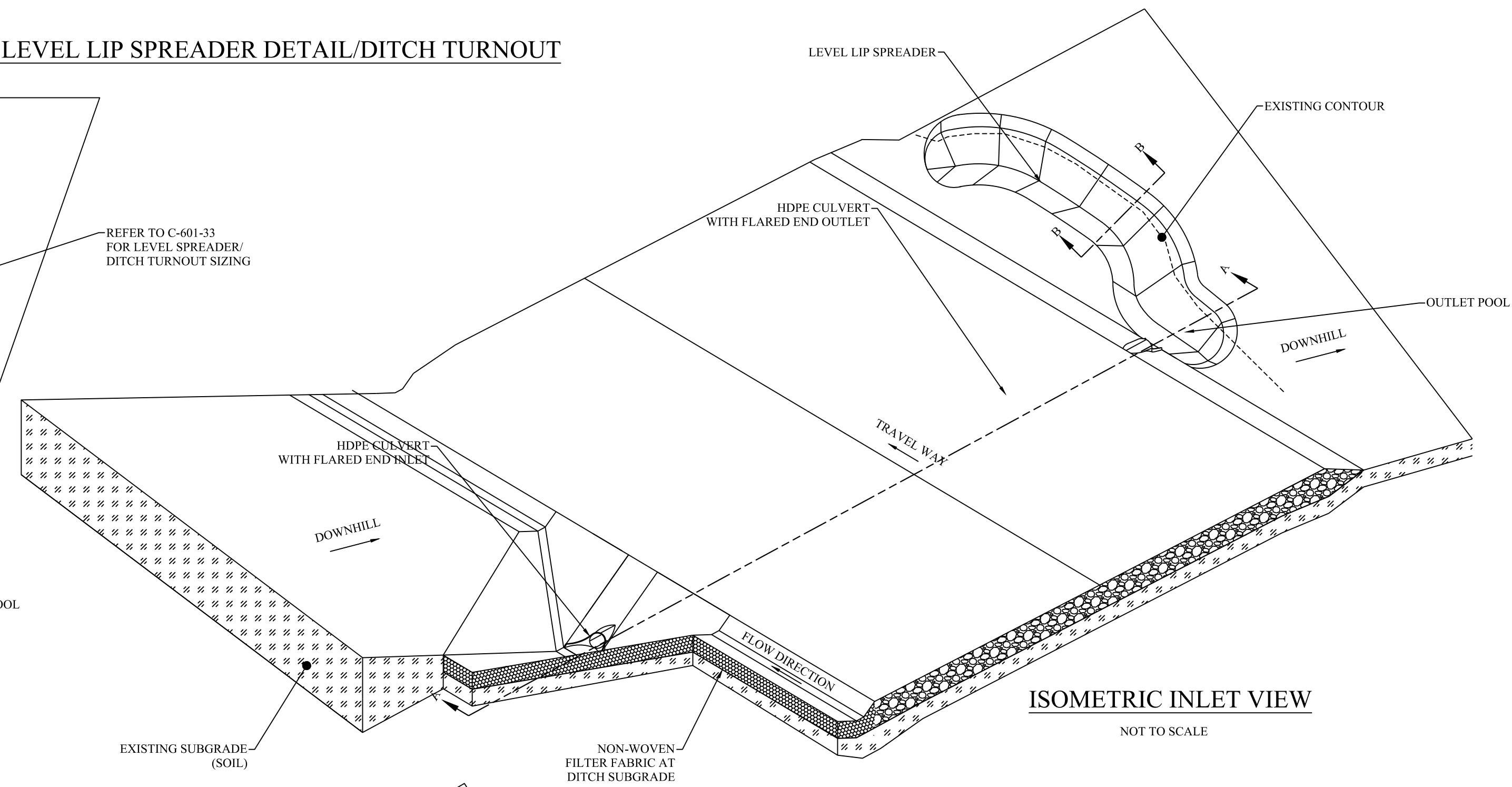

ISOMETRIC INLET VIEW
NOT TO SCALE

- NOTES:**
1. LEVEL LIP SPREADERS/DITCH TURNOUTS ARE TO BE USED AT LOCATIONS SPECIFIED IN PLANS.
 2. CULVERTS, LEVEL LIP SPREADERS, AND DITCH TURNOUTS ARE TO BE SIZED AS SHOWN ON SHEET C-501-30.
 3. IN A LOCATION WHERE BEDROCK OR UNSUITABLE FOR TRENCHING IN A LEVEL LIP SPREADER THE DETAIL ON SHEET C-404-30 IS TO BE USED.
 4. WOVEN FILTER FABRIC MUST HAVE A TENSILE STRENGTH OF 250 LBS AND A PUNCTURE STRENGTH OF 100 LBS. THE APPARENT OPENING SIZE MUST BE OF A U.S. STD. SIEVE NO. 40.
 5. NON-WOVEN FILTER FABRIC MUST HAVE A TENSILE STRENGTH OF 160 LBS AND A PUNCTURE STRENGTH OF 95 LBS. THE APPARENT OPENING SIZE MUST BE OF A U.S. STD. SIEVE NO. 70.
 6. INSPECTIONS BY A PROFESSIONAL ENGINEER SHALL CONSIST OF WEEKLY VISITS TO THE SITE TO INSPECT EACH LEVEL SPREADER CONSTRUCTION, STONE BERM MATERIAL AND PLACEMENT, SETTLING BASIN FROM INITIAL GROUND DISTURBANCE TO FINAL STABILIZATION OF THE LEVEL SPREADER.
 7. INSPECTIONS BY A PROFESSIONAL ENGINEER SHALL CONSIST OF WEEKLY VISITS TO THE SITE TO INSPECT EACH TURNOUT CONSTRUCTION, TURNOUTS STONE BERM MATERIAL AND PLACEMENT, FROM INITIAL GROUND DISTURBANCE TO FINAL STABILIZATION OF THE LEVEL SPREADER.

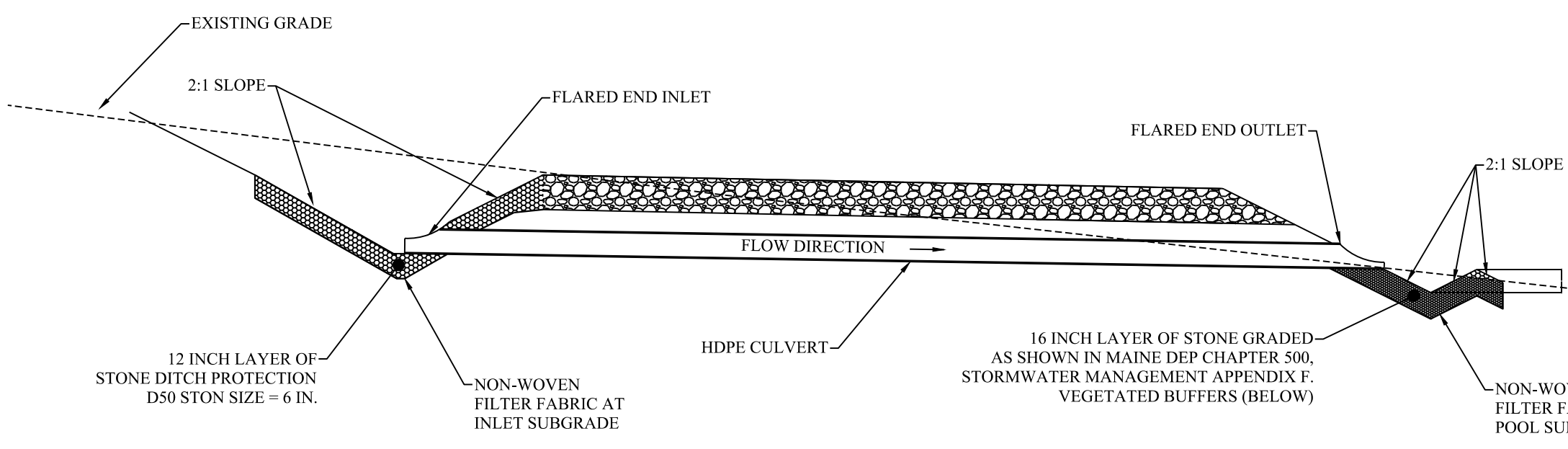

SECTION A-A
NOT TO SCALE

MAINE DEP
CHAPTER 500, STORMWATER MANAGEMENT
APPENDIX F, VEGETATED BUFFERS

SIEVE DESIGNATION	PERCENT BY WEIGHT PASSING SQUARE MESH SIEVES
12 IN.	100
6 IN.	84-100
3 IN.	68-83
1 IN.	42-55
NO.4	8-12

REPLACEMENT CULVERT NOTES:

STREAM CROSSING CULVERT REPLACEMENT MUST:

1. BE LIMITED TO 75 FEET IN LENGTH. THIS LIMIT MAY NOT BE EXCEEDED WITHIN A HALF-MILE LENGTH OF THE STREAM OR WITHIN THE LENGTH OF STREAM CONTROLLED BY THE APPLICANT.
2. FOLLOW THE ALIGNMENT AND GRADE OF THE EXISTING STREAM CHANNEL WHERE POSSIBLE. ON PERENNIAL STREAMS THE CULVERT'S GRADIENT MAY NOT EXCEED 1%.
3. HAVE THE BOTTOM OF THE ENTIRE CULVERT INSTALLED AT OR BELOW STREAM BED ELEVATION, EXCEPT FOR ADDITIONAL CULVERTS AT THE SAME CROSSING.
4. WHERE TWO OR MORE CULVERTS ARE INSTALLED, BE OFFSET IN ORDER TO CONCENTRATE LOW FLOWS INTO THE CULVERT WITHIN THE NATURAL CHANNEL; BE SEATED ON FIRM GROUND, OR ON GEOTEXTILES, LOGS OR OTHER MATERIALS USED TO STABILIZE THE GROUND.
5. BE COVERED BY SOIL TO A MINIMUM DEPTH OF 1 FOOT OR ACCORDING TO THE CULVERT MANUFACTURER'S SPECIFICATIONS, WHICHEVER IS GREATER.
6. HAVE THE SOIL COMPACTED AT LEAST HALFWAY UP THE SIDE OF THE CULVERT.
7. HAVE THE INLET AND OUTLET ENDS STABILIZED BY RIPRAP IN ACCORDANCE WITH SECTION 8 SHORELINE STABILIZATION STANDARDS TO AVOID EROSION OF MATERIAL AROUND THE CULVERT.
8. MUST OCCUR BETWEEN OCTOBER 2 AND JULY 14, OR A TIME PERIOD APPROVED BY THE DEP WHEN THE CROSSING INVOLVES TRENCHING OR DISTURBANCE OF SUBSTRATE IN A RIVER, STREAM OR BROOK. THE APPROVED TIME PERIOD MAY BE THE TIME PERIOD PROPOSED BY THE APPLICANT OR AN ALTERNATIVE TIME PERIOD APPROVED BY THE DEP. AN ALTERNATIVE TIME PERIOD WILL BE REQUIRED WHERE IT APPEARS AN UNREASONABLE IMPACT ON WATER QUALITY OR FISHERIES MAY RESULT AT THE POINT OF CROSSING OR IMMEDIATELY DOWNSTREAM OF THE CROSSING. THE APPLICANT WILL BE NOTIFIED BY THE DEP WITHIN 14 DAYS IF AN ALTERNATIVE TIME PERIOD, OTHER THAN THE ONE PROPOSED BY THE APPLICANT, IS REQUIRED FOR CONSTRUCTING THE CROSSING.

STREAM CROSSING AND DRAINAGE CULVERT REPLACEMENT MUST:

9. HAVE EXCAVATED MATERIAL STOCKPILED EITHER OUTSIDE THE WETLAND OR ON MATS OR PLATFORMS. HAY BALES, SILT FENCE OR EROSION CONTROL MIX BERM MUST BE USED, WHERE NECESSARY, TO PREVENT SEDIMENTATION.
10. USE UNTREATED LUMBER FOR TIMBER MATTING. LUMBER PRESSURE TREATED WITH CHROMATED COPPER ARSENATE (CCA) MAY BE USED ONLY IF NECESSARY AND ONLY IF USE IS ALLOWED UNDER FEDERAL LAW AND NOT PROHIBITED FROM SALE UNDER 38 M.R.S.A. 1682, AND PROVIDED IT IS CURED ON DRY LAND IN A WAY THAT EXPOSURE TO SURFACES TO THE AIR FOR A PERIOD OF AT LEAST 21 DAYS PRIOR TO CONSTRUCTION. WOOD TREATED WITH CREOSOTE OR PENTACHLOROPHENOL MAY NOT BE USED WHERE IT WILL CONTACT WATER.

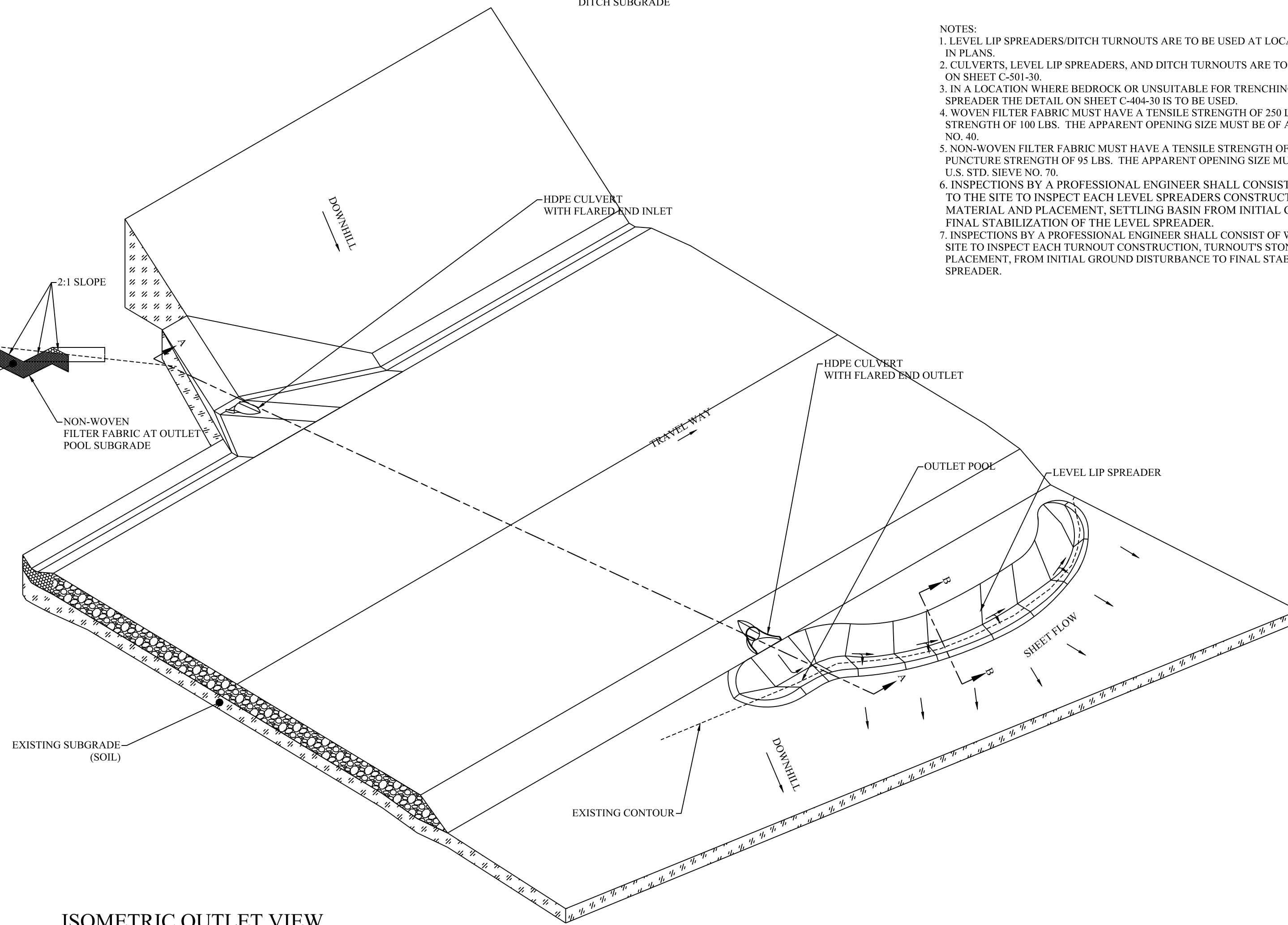

ISOMETRIC OUTLET VIEW
NOT TO SCALE

GENERAL NOTES:

1. SCALES NOTED ARE APPLICABLE TO FULL SIZE (24"x36") DRAWINGS ONLY. SCALE REDUCED DRAWINGS ACCORDINGLY.
2. NORTH AS SHOWN HEREON IS REFERENCED TO GRID NORTH, NAD83 MAINE STATE PLANES, WEST ZONE, US FOOT.
3. ELEVATIONS AS SHOWN HEREON ARE REFERENCED TO NAD 83.
4. EXISTING TOPOGRAPHIC AND PLANIMETRIC SURVEY INFORMATION AS SHOWN HEREON IS THE RESULT OF AERIAL TOPOGRAPHIC MAPPING COMPLETED BY PHOTOGRAMMETRIC TECHNOLOGY, INC. DEVELOPED FROM AERIAL PHOTOGRAPHY COMPLETED BY PHOTOGRAMMETRIC TECHNOLOGY, INC.
5. ENVIRONMENTAL RESOURCE MAPPING (WETLANDS, STREAMS, VERNAL POOLS, ETC.) AS SHOWN HEREON BY TETRA TECH.
6. INVERTS SHOWN ON PROPOSED CULVERTS MAY BE ADJUSTED BASED ON FIELD CONDITIONS.

No.	Revision/Issue	Date

PATRIOT RENEWABLES

EMS
ENGINEERING & MANAGEMENT SERVICES, INC.
505 SOUTH STREET, SUITE 100, BOSTON, MA 02116
TEL: (617) 552-0800 FAX: (617) 552-0600

Stamp:

Drawing Title:
CULVERT AND LEVEL LIP SPREADER/DITCH TURNOUT DETAILS AND NOTES

Date:	05/25/2021	Scale:	AS SHOWN
Drawn By:	GAD	Chk'd By:	RSC
Project:	WESTERN MAINE RENEWABLE ENERGY PROJECT		
Address:	MOSCOW, ME		
Client:	WESTERN MAINE RENEWABLES		
Sheet Number:	53 OF 62		

Dwg No.:
C-403

**CULVERT AND LEVEL LIP SPREADER DETAIL/DITCH TURNOUT
IN LOCATIONS OF EXISTING BEDROCK**

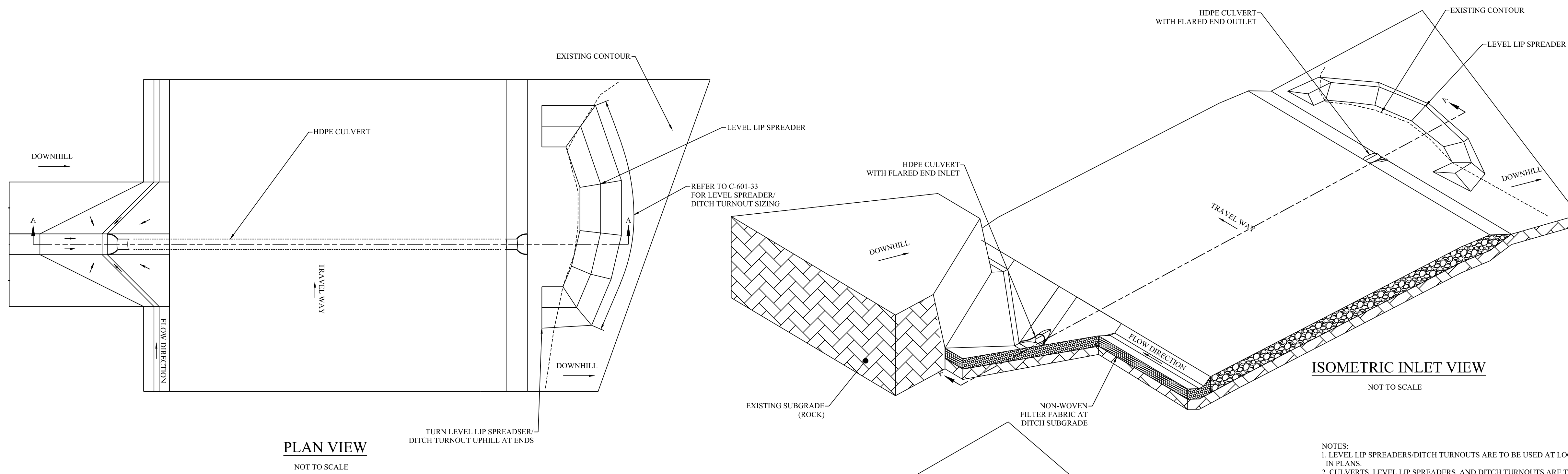

PLAN VIEW
NOT TO SCALE

ISOMETRIC INLET VIEW
NOT TO SCALE

- NOTES:
1. LEVEL LIP SPREADERS/DITCH TURNOUTS ARE TO BE USED AT LOCATIONS SPECIFIED IN PLANS.
 2. CULVERTS, LEVEL LIP SPREADERS, AND DITCH TURNOUTS ARE TO BE SIZED AS SHOWN ON SHEET C-501-30.
 3. WOVEN FILTER FABRIC MUST HAVE A TENSILE STRENGTH OF 250 LBS AND A PUNCTURE STRENGTH OF 100 LBS. THE APPARENT OPENING SIZE MUST BE OF A U.S. STD. SIEVE NO. 40.
 4. NON-WOVEN FILTER FABRIC MUST HAVE A TENSILE STRENGTH OF 160 LBS AND A PUNCTURE STRENGTH OF 95 LBS. THE APPARENT OPENING SIZE MUST BE OF A U.S. STD. SIEVE NO. 70.
 6. INSPECTIONS BY A PROFESSIONAL ENGINEER SHALL CONSIST OF WEEKLY VISITS TO THE SITE TO INSPECT EACH LEVEL SPREADER'S CONSTRUCTION, STONE BERM MATERIAL AND PLACEMENT, SETTLING BASIN FROM INITIAL GROUND DISTURBANCE TO FINAL STABILIZATION OF THE LEVEL SPREADER.
 7. INSPECTIONS BY A PROFESSIONAL ENGINEER SHALL CONSIST OF WEEKLY VISITS TO THE SITE TO INSPECT EACH TURNOUT CONSTRUCTION, TURNOUT'S STONE BERM MATERIAL AND PLACEMENT, FROM INITIAL GROUND DISTURBANCE TO FINAL STABILIZATION OF THE LEVEL SPREADER.

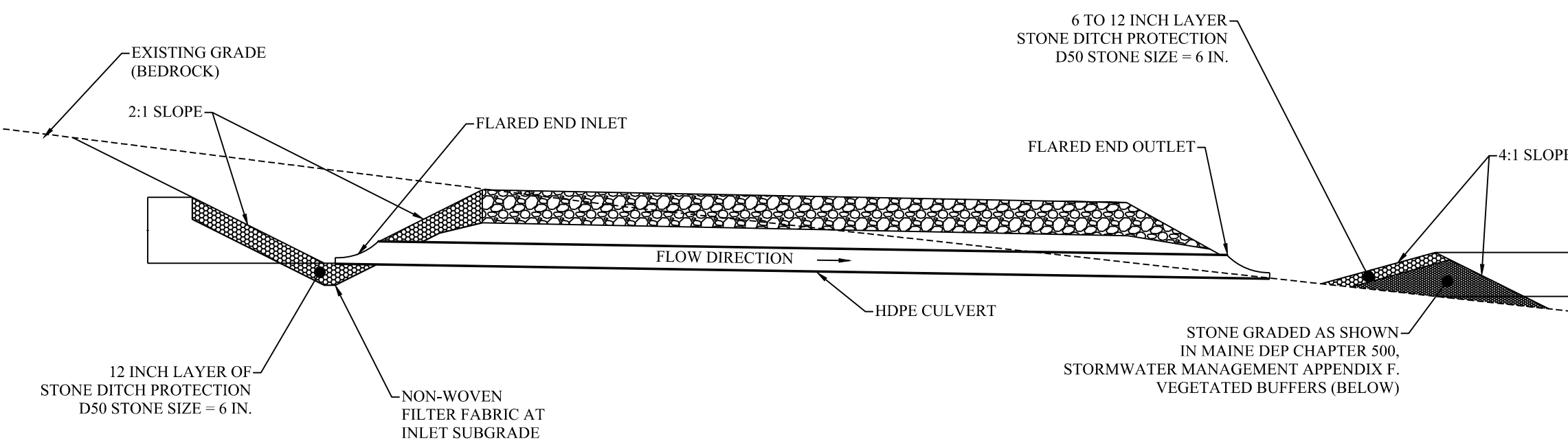

SECTION A-A
NOT TO SCALE

MAINE DEP
CHAPTER 500, STORMWATER MANAGEMENT
APPENDIX F, VEGETATED BUFFERS

SIEVE DESIGNATION	PERCENT BY WEIGHT PASSING SQUARE MESH SIEVES
12 IN.	100
6 IN.	84-100
3 IN.	68-83
1 IN.	42-55
NO.4	8-12

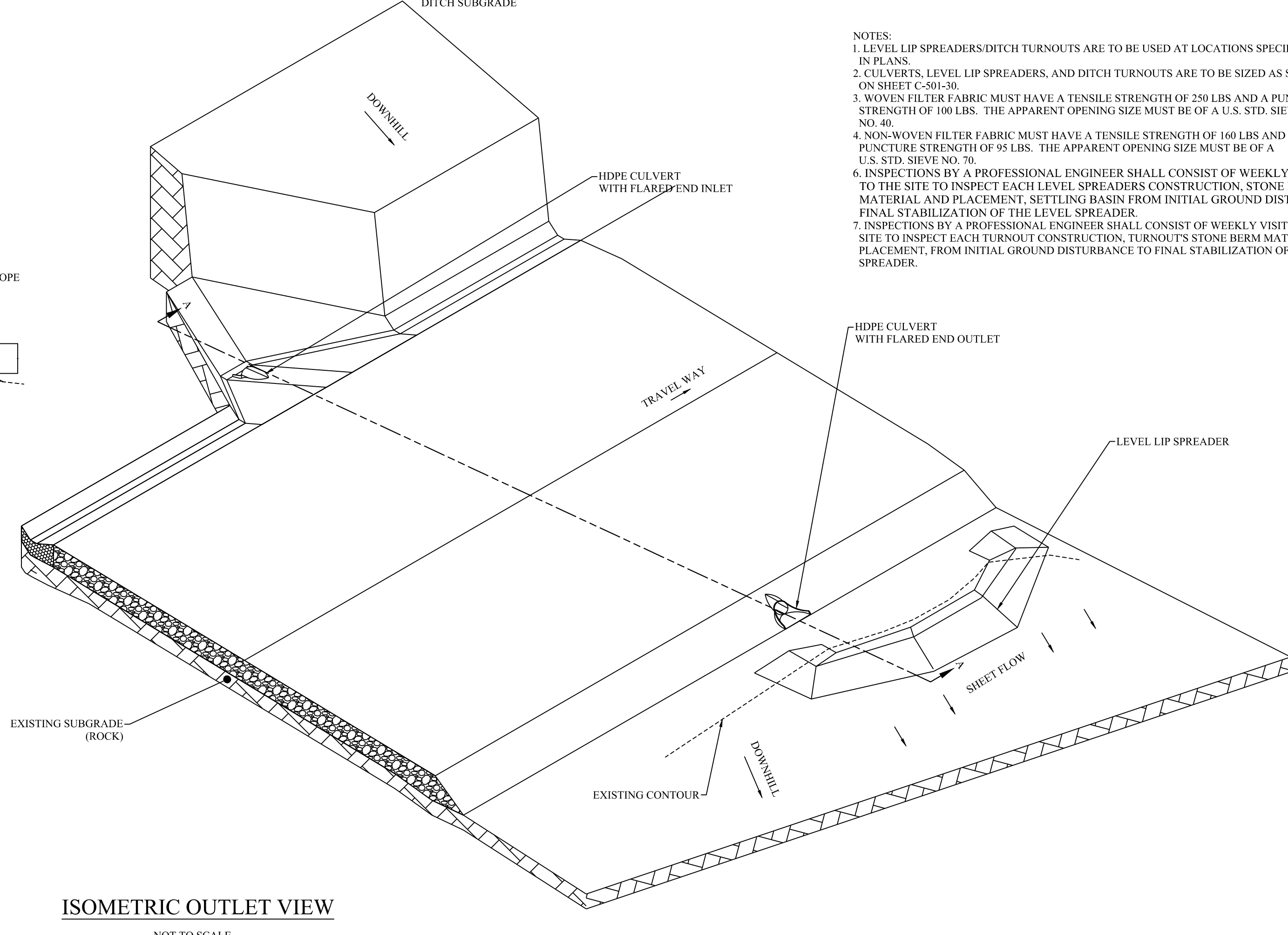

ISOMETRIC OUTLET VIEW
NOT TO SCALE

- REPLACEMENT CULVERT NOTES:**
- STREAM CROSSING CULVERT REPLACEMENT MUST:**
1. BE LIMITED TO 75 FEET IN LENGTH. THIS LIMIT MAY NOT BE EXCEEDED WITHIN A HALF-MILE LENGTH OF THE STREAM OR WITHIN THE LENGTH OF STREAM CONTROLLED BY THE APPLICANT.
 2. FOLLOW THE ALIGNMENT AND GRADE OF THE EXISTING STREAM CHANNEL WHERE POSSIBLE. ON PERENNIAL STREAMS THE CULVERT'S GRADIENT MAY NOT EXCEED 1%.
 3. HAVE THE BOTTOM OF THE ENTIRE CULVERT INSTALLED AT OR BELOW STREAM BED ELEVATION, EXCEPT FOR ADDITIONAL CULVERTS AT THE SAME CROSSING.
 4. WHERE TWO OR MORE CULVERTS ARE INSTALLED, BE OFFSET IN ORDER TO CONCENTRATE LOW FLOWS INTO THE CULVERT WITHIN THE NATURAL CHANNEL; BE SEATED ON FIRM GROUND, OR ON GEOTEXTILES, LOGS OR OTHER MATERIALS USED TO STABILIZE THE GROUND.
 5. BE COVERED BY SOIL TO A MINIMUM DEPTH OF 1 FOOT OR ACCORDING TO THE CULVERT MANUFACTURER'S SPECIFICATIONS, WHICHEVER IS GREATER.
 6. HAVE THE SOIL COMPACTED AT LEAST HALF WAY UP THE SIDE OF THE CULVERT.
 7. HAVE THE INLET AND OUTLET ENDS STABILIZED BY RIPRAP IN ACCORDANCE WITH SECTION 8 SHORELINE STABILIZATION STANDARDS TO AVOID EROSION OF MATERIAL AROUND THE CULVERT.
 8. MUST OCCUR BETWEEN OCTOBER 2 AND JULY 14, OR A TIME PERIOD APPROVED BY THE DEP WHEN THE CROSSING INVOLVES TRENCHING OR DISTURBANCE OF SUBSTRATE IN A RIVER, STREAM OR BROOK. THE APPROVED TIME PERIOD MAY BE THE TIME PERIOD PROPOSED BY THE APPLICANT OR AN ALTERNATIVE TIME PERIOD APPROVED BY THE DEP. AN ALTERNATIVE TIME PERIOD WILL BE REQUIRED WHERE IT APPEARS AN UNREASONABLE IMPACT ON WATER QUALITY OR FISHERIES MAY RESULT AT THE POINT OF CROSSING OR IMMEDIATELY DOWNSTREAM OF THE CROSSING. THE APPLICANT WILL BE NOTIFIED BY THE DEP WITHIN 14 DAYS IF AN ALTERNATIVE TIME PERIOD, OTHER THAN THE ONE PROPOSED BY THE APPLICANT, IS REQUIRED FOR CONSTRUCTING THE CROSSING.
- STREAM CROSSING AND DRAINAGE CULVERT REPLACEMENT MUST:**
9. HAVE EXCAVATED MATERIAL STOCKPILED EITHER OUTSIDE THE WETLAND OR ON MATS OR PLATFORMS. HAY BALES, SILT FENCE OR EROSION CONTROL MIX BERM MUST BE USED, WHERE NECESSARY, TO PREVENT SEDIMENTATION.
 10. USE UNTREATED LUMBER FOR TIMBER MATTING. LUMBER PRESSURE TREATED WITH CHROMATED COPPER ARSENATE (CCA) MAY BE USED ONLY IF NECESSARY AND ONLY IF USE IS ALLOWED UNDER FEDERAL LAW AND NOT PROHIBITED FROM SALE UNDER 38 M.R.S.A. 1682, AND PROVIDED IT IS CURED ON DRY LAND IN A WAY THAT EXPOSES ALL SURFACES TO THE AIR FOR A PERIOD OF AT LEAST 21 DAYS PRIOR TO CONSTRUCTION. WOOD TREATED WITH CREOSOTE OR PENTACHLOROPHENOL MAY NOT BE USED WHERE IT WILL CONTACT WATER.

GENERAL NOTES:

1. SCALES NOTED ARE APPLICABLE TO FULL SIZE (24"x36") DRAWINGS ONLY. SCALE REDUCED DRAWINGS ACCORDINGLY.
2. NORTH AS SHOWN HEREON IS REFERENCED TO GRID NORTH, NAD83 MAINE STATE PLANES, WEST ZONE, US FOOT.
3. ELEVATIONS AS SHOWN HEREON ARE REFERENCED TO NAD 83.
4. EXISTING TOPOGRAPHIC AND PLANIMETRIC SURVEY INFORMATION AS SHOWN HEREON IS THE RESULT OF AERIAL TOPOGRAPHIC MAPPING COMPLETED BY PHOTOGRAMMETRIC TECHNOLOGY, INC. DEVELOPED FROM AERIAL PHOTOGRAPHY COMPLETED BY PHOTOGRAMMETRIC TECHNOLOGY, INC.
5. ENVIRONMENTAL RESOURCE MAPPING (WETLANDS, STREAMS, VERNAL POOLS, ETC.) AS SHOWN HEREON BY TETRA TECH.
6. INVERTS SHOWN ON PROPOSED CULVERTS MAY BE ADJUSTED BASED ON FIELD CONDITIONS.

No.	Revision/Issue	Date

PATRIOT RENEWABLES

ENGINEERING & MANAGEMENT SERVICES, INC.
565 SOUTH STREET, SUITE 100, WESTPORT, MAINE 04091
TEL: (877) 850-0000 FAX: (877) 850-0001

Stamp:

Drawing Title:

**CULVERT
AND
LEVEL LIP SPREADER/
DITCH TURNOUT
(BEDROCK)
DETAILS AND NOTES**

Date:	05/25/2021	Scale:	AS SHOWN
Drawn By:	GAD	Chk'd By:	RSC
Project:	WESTERN MAINE RENEWABLE ENERGY PROJECT		
Address:	MOSCOW, ME		
Client:	WESTERN MAINE RENEWABLES		
Sheet Number:	54 OF 62		

Dwg No.:

C-404

ROCK SANDWICH DETAIL AND NOTES

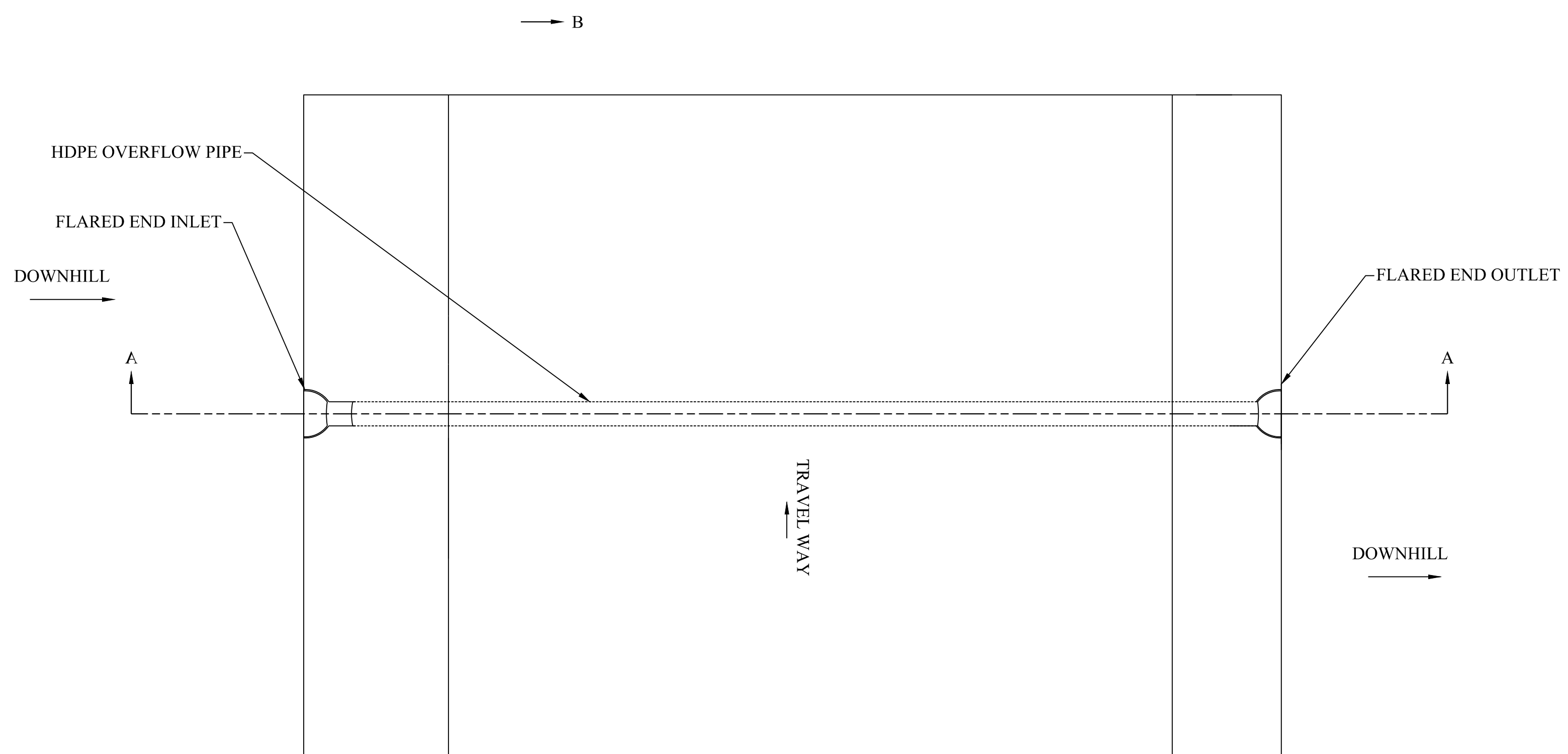

PLAN VIEW
NOT TO SCALE

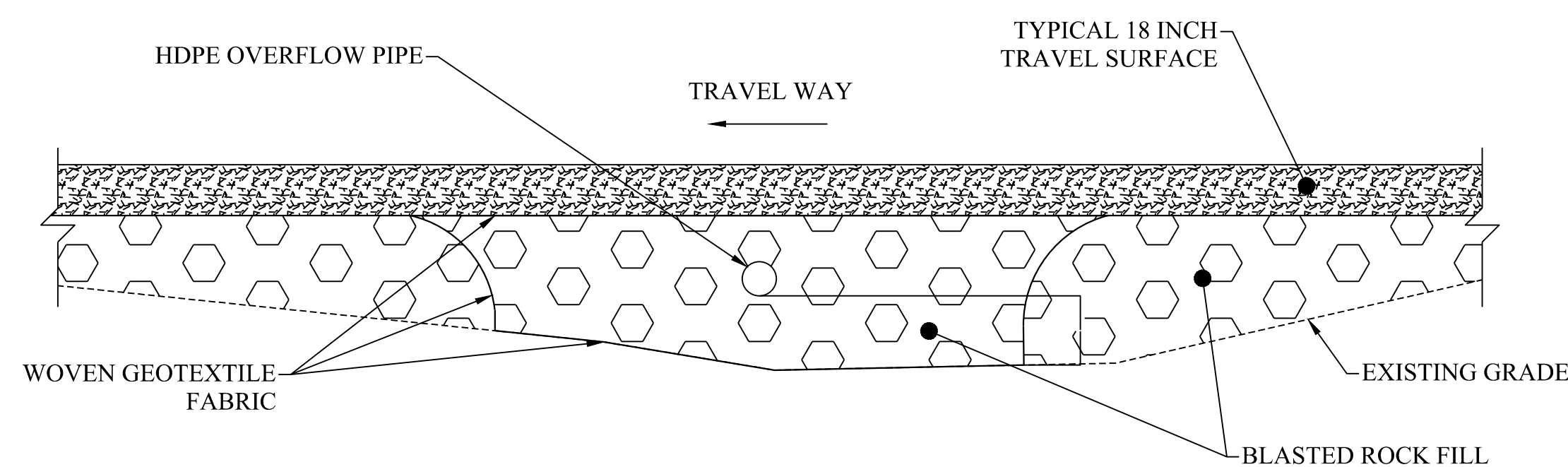

SECTION B-B
NOT TO SCALE

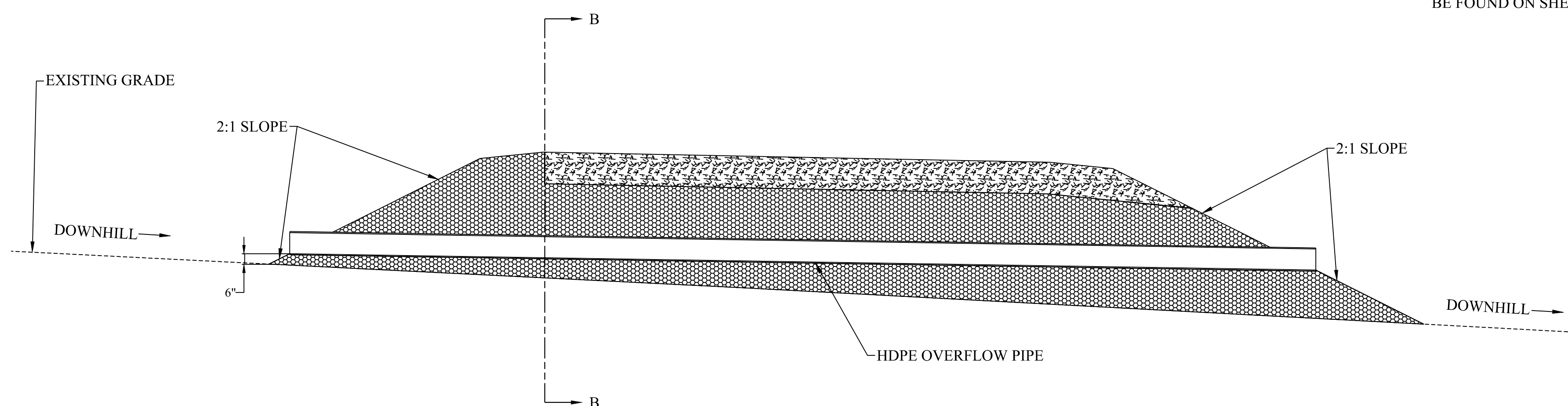

SECTION A-A
NOT TO SCALE

- NOTES:**
1. WOVEN FILTER FABRIC MUST HAVE A TENSILE STRENGTH OF 250 LBS AND A PUNCTURE STRENGTH OF 100 LBS. THE APPARENT OPENING SIZE MUST BE OF A U.S. STD. SIEVE NO. 40.
 2. NON-WOVEN FILTER FABRIC MUST HAVE A TENSILE STRENGTH OF 160 LBS AND A PUNCTURE STRENGTH OF 95 LBS. THE APPARENT OPENING SIZE MUST BE OF A U.S. STD. SIEVE NO. 70.
 3. SIZING FOR ROCK SANDWICH OVERFLOW PIPES CAN BE FOUND ON SHEET C-501-29

GENERAL NOTES:

1. SCALES NOTED ARE APPLICABLE TO FULL SIZE (24"X36") DRAWINGS ONLY. SCALE REDUCED DRAWINGS ACCORDINGLY.
2. NORTH AS SHOWN HEREON IS REFERENCED TO GRID NORTH, NAD83 MAINE STATE PLANES, WEST ZONE, US FOOT.
3. ELEVATIONS AS SHOWN HEREON ARE REFERENCED TO NAD 83.
4. EXISTING TOPOGRAPHIC AND PLANIMETRIC SURVEY INFORMATION AS SHOWN HEREON IS THE RESULT OF AERIAL TOPOGRAPHIC MAPPING COMPLETED BY PHOTOGRAMMETRIC TECHNOLOGY, INC. DEVELOPED FROM AERIAL PHOTOGRAPHY COMPLETED BY PHOTOGRAMMETRIC TECHNOLOGY, INC.
5. ENVIRONMENTAL RESOURCE MAPPING (WETLANDS, STREAMS, VERNAL POOLS, ETC.) AS SHOWN HEREON BY TETRA TECH.
6. INVERTS SHOWN ON PROPOSED CULVERTS MAY BE ADJUSTED BASED ON FIELD CONDITIONS.

No.	Revision/Issue	Date

PATRIOT RENEWABLES
EMS
ENGINEERING & MANAGEMENT SERVICES, INC.
540 SOUTH STREET, SUITE 100, WILTON, MA 01897
TEL: (978) 650-0000 FAX: (978) 650-0005

Stamp:

Drawing Title:
**ROCK SANDWICH
DETAILS AND NOTES**

Date: 05/25/2021	Scale: AS SHOWN
Drawn By: GAD	Chk'd By: RSC
Project: WESTERN MAINE RENEWABLE ENERGY PROJECT	
Address: MOSCOW, ME	
Client: WESTERN MAINE RENEWABLES	
Sheet Number: 55 OF 62	

Desig. No.:
C-405

ROCK MAKI DETAIL AND NOTES

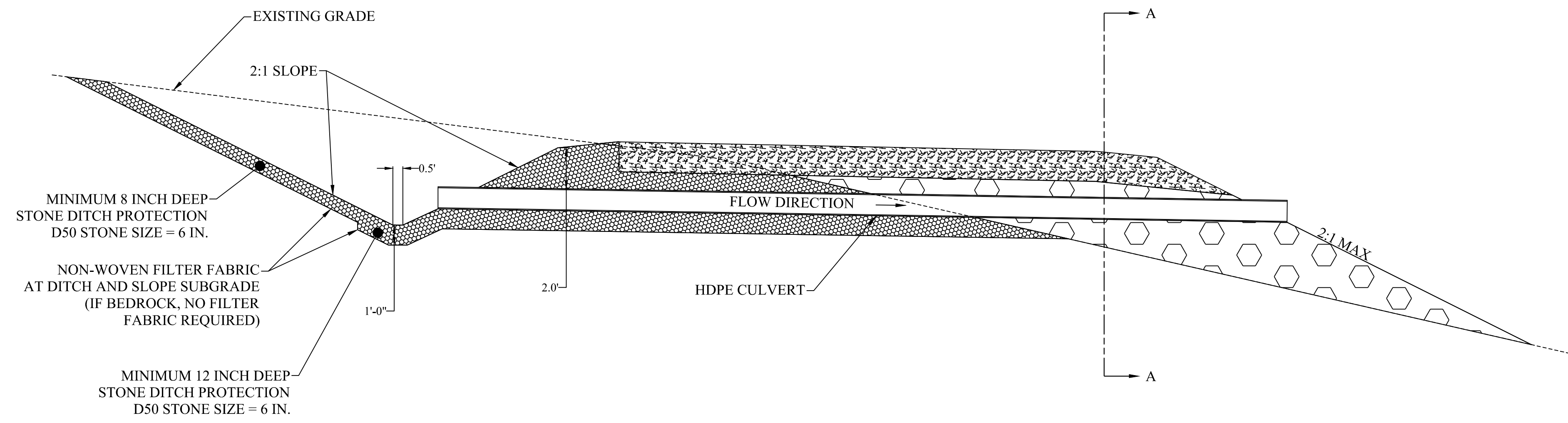

ROCK MAKI CROSS SECTION DETAIL

NOT TO SCALE

- NOTE:**
1. ROCK MAKI SECTION IS TO BE USED IN AREAS WHERE A DITCH INTERCEPTS EXISTING SOIL CONTAINING A HIGH WATER TABLE, AS WELL AS LOCATIONS SPECIFIED ON PLANS.
 2. WOVEN FILTER FABRIC MUST HAVE A TENSILE STRENGTH OF 250 LBS AND A PUNCTURE STRENGTH OF 100 LBS. THE APPARENT OPENING SIZE MUST BE OF A U.S. STD. SIEVE NO. 40.
 3. NON-WOVEN FILTER FABRIC MUST HAVE A TENSILE STRENGTH OF 160 LBS AND A PUNCTURE STRENGTH OF 95 LBS. THE APPARENT OPENING SIZE MUST BE OF A U.S. STD. SIEVE NO. 70.

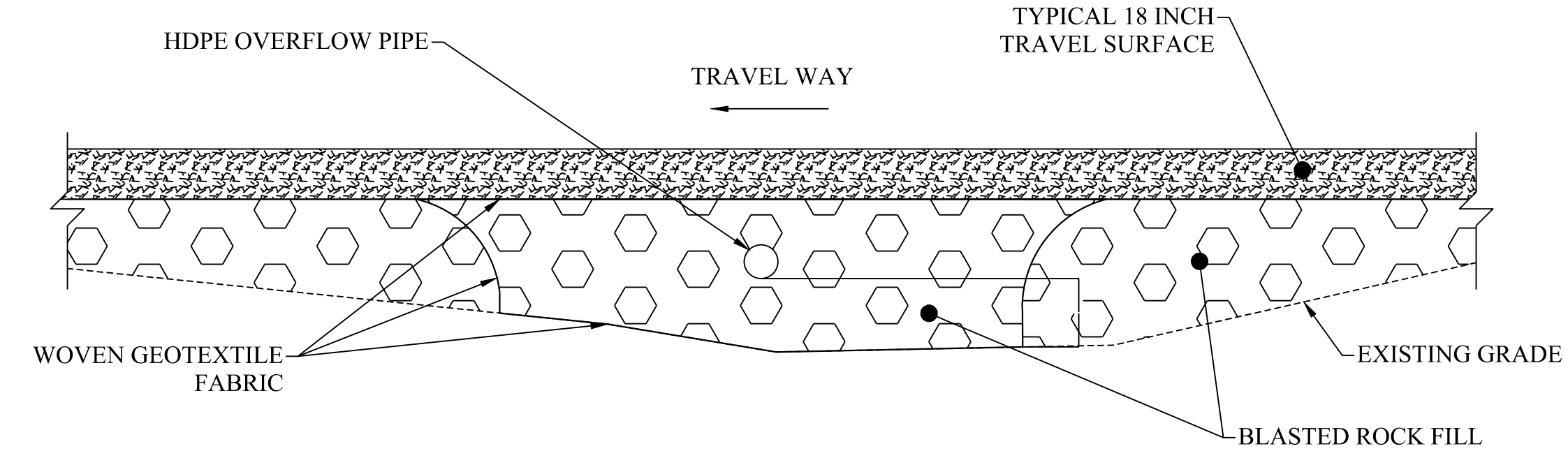

SECTION A-A

NOT TO SCALE

GENERAL NOTES:

1. SCALES NOTED ARE APPLICABLE TO FULL SIZE (24"x36") DRAWINGS ONLY. SCALE REDUCED DRAWINGS ACCORDINGLY.
2. NORTH AS SHOWN HEREON IS REFERENCED TO GRID NORTH, NAD83 MAINE STATE PLANES, WEST ZONE, US FOOT.
3. ELEVATIONS AS SHOWN HEREON ARE REFERENCED TO NAD 83.
4. EXISTING TOPOGRAPHIC AND PLANIMETRIC SURVEY INFORMATION AS SHOWN HEREON IS THE RESULT OF AERIAL TOPOGRAPHIC MAPPING COMPLETED BY PHOTOGRAMMETRIC TECHNOLOGY, INC. DEVELOPED FROM AERIAL PHOTOGRAPHY COMPLETED BY PHOTOGRAMMETRIC TECHNOLOGY, INC.
5. ENVIRONMENTAL RESOURCE MAPPING (WETLANDS, STREAMS, VERNAL POOLS, ETC.) AS SHOWN HEREON BY TETRA TECH.
6. INVERTS SHOWN ON PROPOSED CULVERTS MAY BE ADJUSTED BASED ON FIELD CONDITIONS.

No.	Revision/Issue	Date

PATRIOT RENEWABLES
EMS
ENGINEERING & MANAGEMENT SERVICES, INC.
545 SOUTH STREET, CORVALLIS, MAE 02149
TEL (877) 850-0000 FAX (877) 850-0000

Stamp:

Drawing Title:
**ROCK MAKI
DETAILS AND NOTES**

Date:	05/25/2021	Scale:	AS SHOWN
Drawn By:	GAD	Chk'd By:	RSC
Project:	WESTERN MAINE RENEWABLE ENERGY PROJECT		
Address:	MOSCOW, ME		
Client:	WESTERN MAINE RENEWABLES		
Sheet Number:	56 OF 62		

Desig No.:
C-406

CULVERT INLET DETAIL

NOT TO SCALE

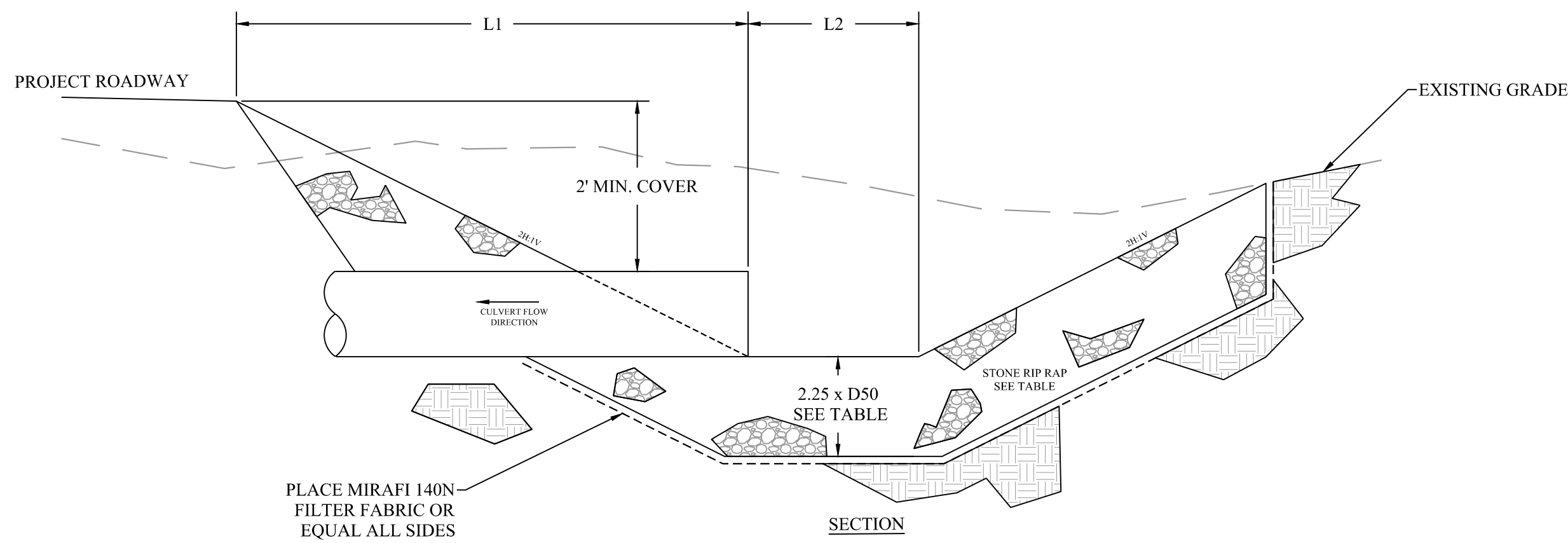

PLACE MIRAFI 140N FILTER FABRIC OR EQUAL ALL SIDES

SECTION

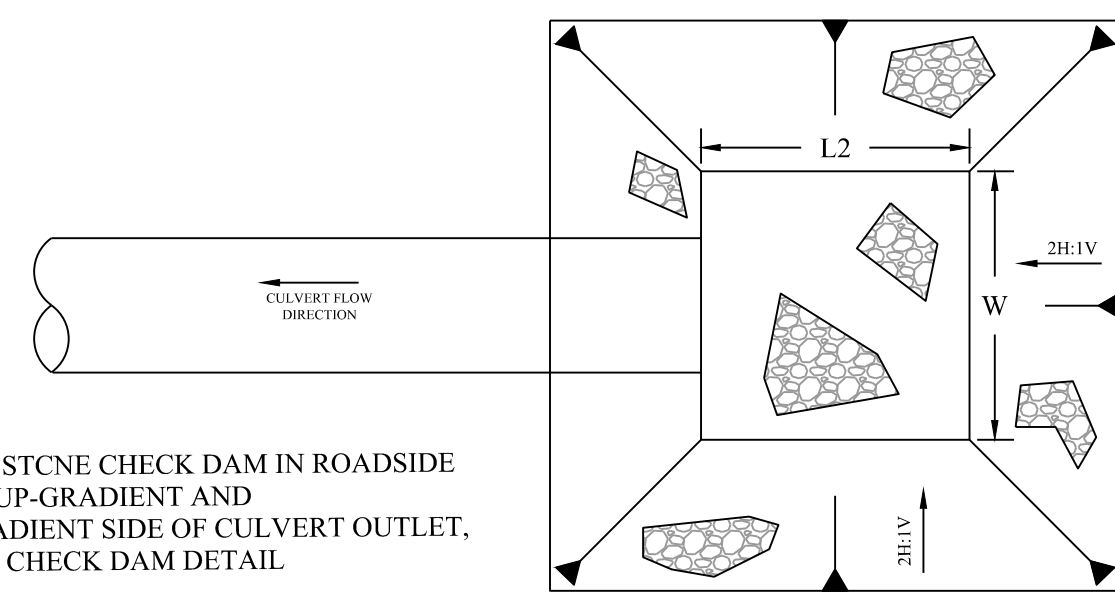

PLAN

NOTE:
1. INSTALL STONE CHECK DAM IN ROADSIDE DITCH ON UP-GRADIENT AND DOWN-GRADIENT SIDE OF CULVERT OUTLET. SEE STONE CHECK DAM DETAIL

SCHEDULE					
CULVERT DIA.	L1	L2	W	STONE D50	2.25 x D50
12"	6'	2'	2'	6"	14"
15"	6.5'	4'	4'	6"	14"
18"	7'	4'	4'	6"	14"
24"	8'	8'	8'	6"	14"
36"	10'	8'	8'	12"	27"

STONE CHECK DAM DETAIL

NOT TO SCALE

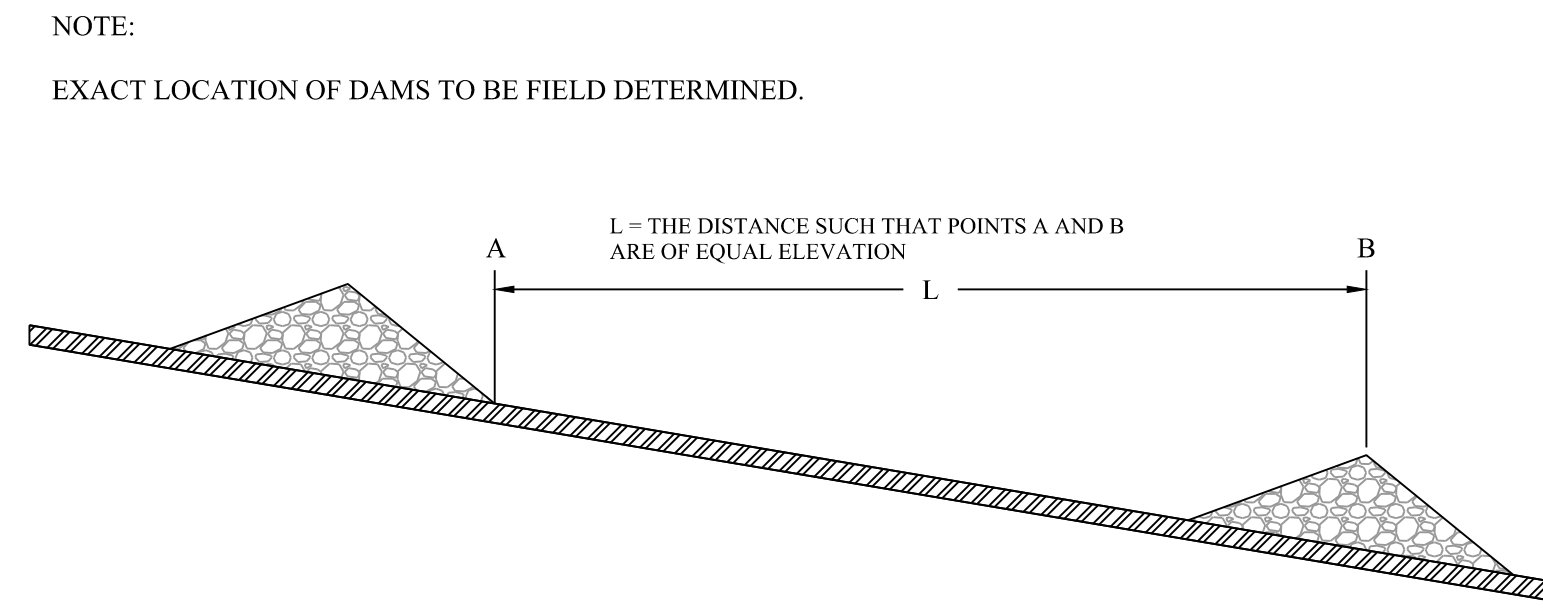

NOTE:
EXACT LOCATION OF DAMS TO BE FIELD DETERMINED.

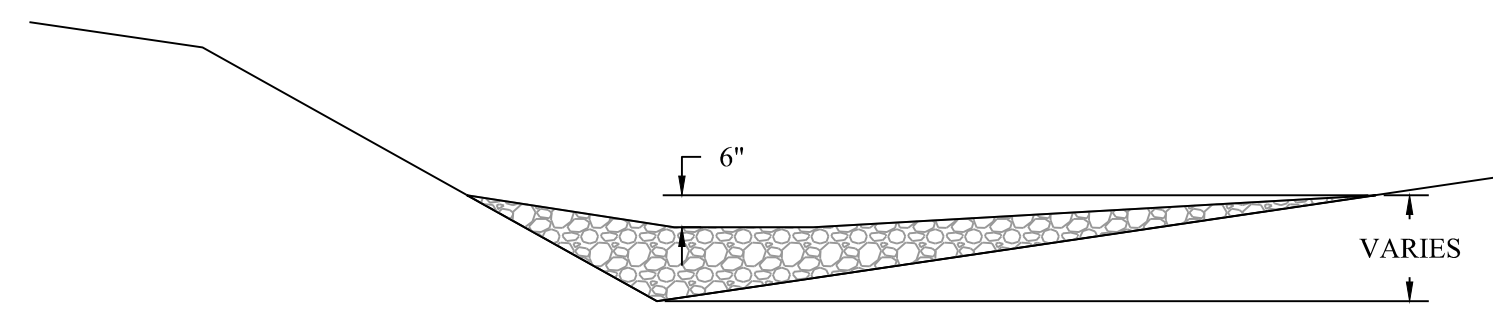

MDOT STONE FOR FRESH DRAINS (MDOT 703.24)

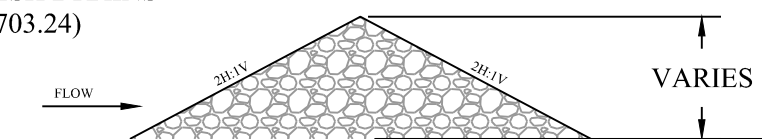

CULVERT OUTLET / PLUNGE POOL DETAIL

NOT TO SCALE

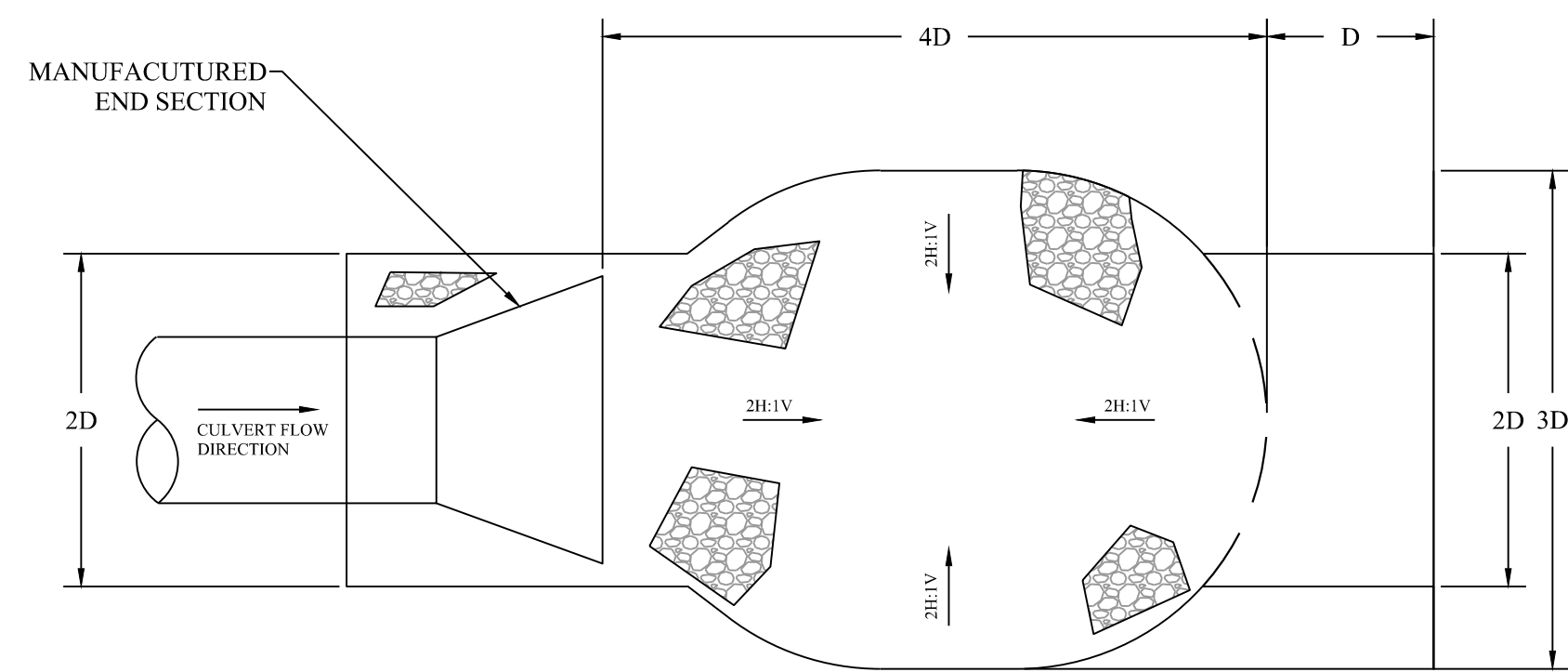

PLAN

SCHEDULE		
CULVERT DIA.	STONE D50	2.25 x D50
12"	6"	14"
15"	6"	14"
18"	6"	14"
24"	6"	14"
36"	12"	27"

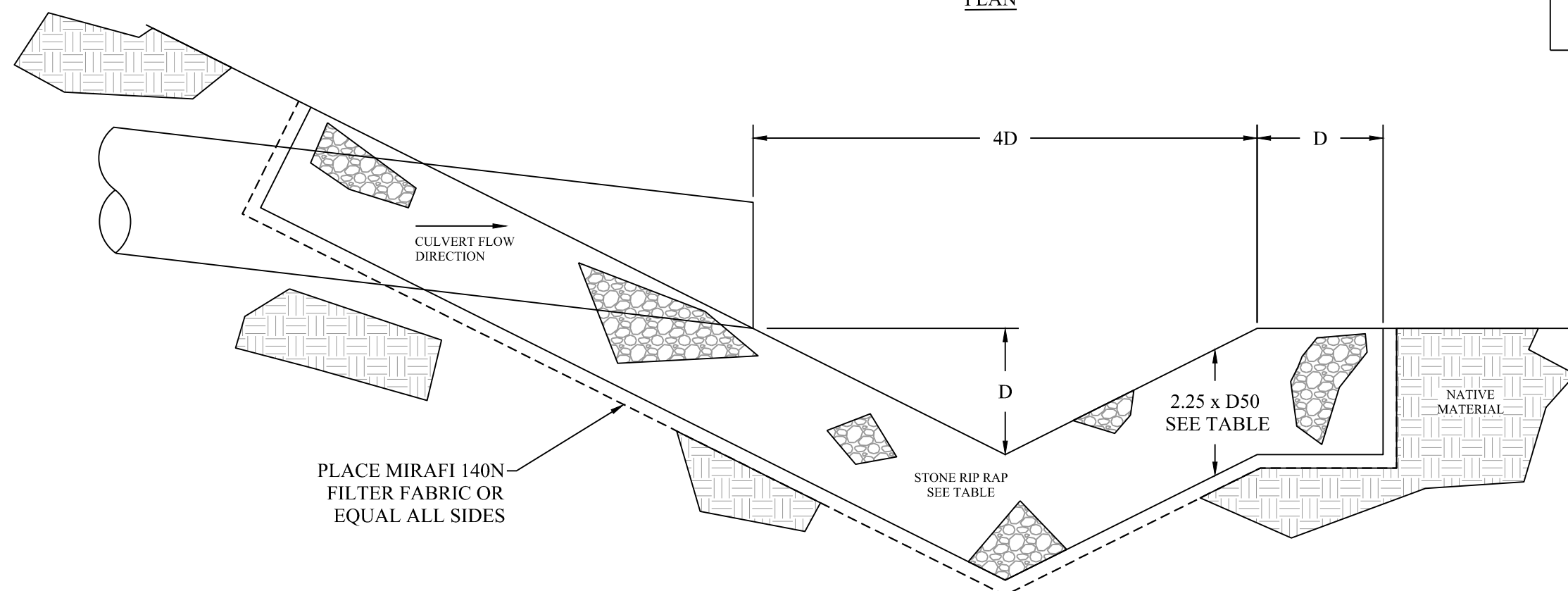

SECTION

PLACE MIRAFI 140N FILTER FABRIC OR EQUAL ALL SIDES

DRAINAGE MANHOLE DETAIL

NOT TO SCALE

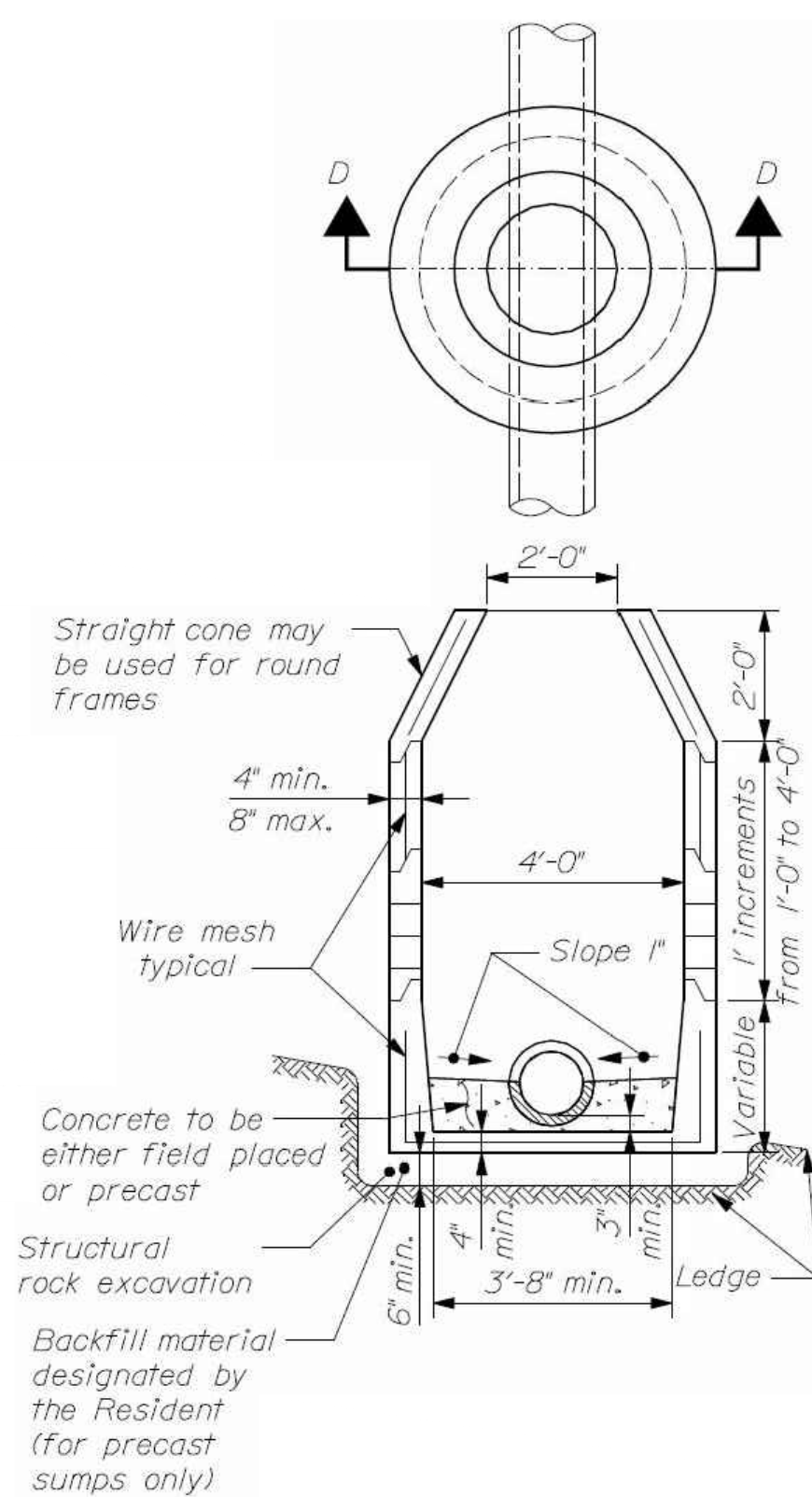

GENERAL NOTES:

1. SCALES NOTED ARE APPLICABLE TO FULL SIZE (24"x36") DRAWINGS ONLY. SCALE REDUCED DRAWINGS ACCORDINGLY.
2. NORTH AS SHOWN HEREON IS REFERENCED TO GRID NORTH, NAD83 MAINE STATE PLANES, WEST ZONE, US FOOT.
3. ELEVATIONS AS SHOWN HEREON ARE REFERENCED TO NAD 83.
4. EXISTING TOPOGRAPHIC AND PLANIMETRIC SURVEY INFORMATION AS SHOWN HEREON IS THE RESULT OF AERIAL TOPOGRAPHIC MAPPING COMPLETED BY PHOTOGRAMMETRIC TECHNOLOGY, INC. DEVELOPED FROM AERIAL PHOTOGRAPHY COMPLETED BY PHOTOGRAMMETRIC TECHNOLOGY, INC.
5. ENVIRONMENTAL RESOURCE MAPPING (WETLANDS, STREAMS, VERNAL POOLS, ETC.) AS SHOWN HEREON BY TETRA TECH.
6. INVERTS SHOWN ON PROPOSED CULVERTS MAY BE ADJUSTED BASED ON FIELD CONDITIONS.

No.	Revision/Issue	Date

PATRIOT RENEWABLES
EMS
 ENGINEERING & MANAGEMENT SERVICES, INC.
340 SOUTH STREET, CORVY, MA 01039
 TEL: (977) 850-0800 FAX: (977) 850-0505

Stamp:

Drawing Title:
CULVERT INLET DETAIL
CULVERT OUTLET/PLUNGE POOL DETAIL
DIVERSION BERM DETAIL AND NOTES

Date: 05/25/2021	Scale: AS SHOWN
Drawn By: GAD	Chk'd By: RSC
Project: WESTERN MAINE RENEWABLE ENERGY PROJECT	
Address: MOSCOW, ME	
Client: WESTERN MAINE RENEWABLES	
Sheet Number: 57 OF 62	

Dwg No.: **C-407**

REVEGETATION DETAILS AND NOTES

38' ACCESS ROAD REVEGETATION DETAIL
NOT TO SCALE

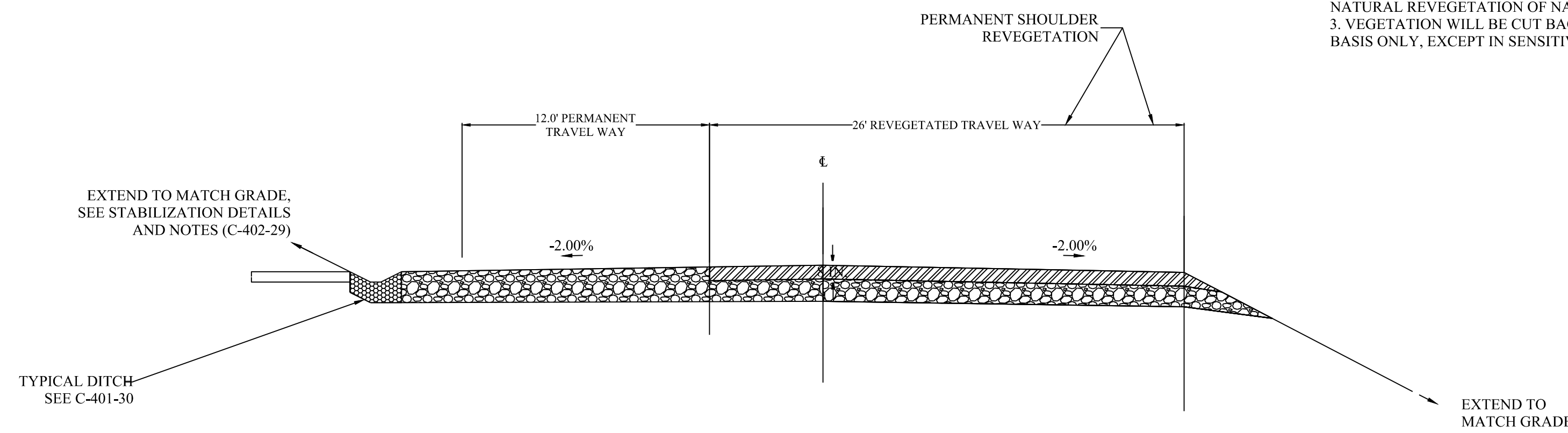

- NOTE:
1. TEMPORARY SHOULDERS ALONG PERMANENT ACCESS ROAD TO BE REVEGETATED.
 2. EROSION CONTROL MIX OR LOAM & SEED WILL BE PLACED ON THE REVEGETATED AREAS TO PROMOTE NATURAL REVEGETATION OF NATIVE SPECIES.
 3. VEGETATION WILL BE CUT BACK ON AN ANNUAL BASIS ONLY, EXCEPT IN SENSITIVE VIEW SHEDS.

38' CRANE ROAD REVEGETATION DETAIL
NOT TO SCALE

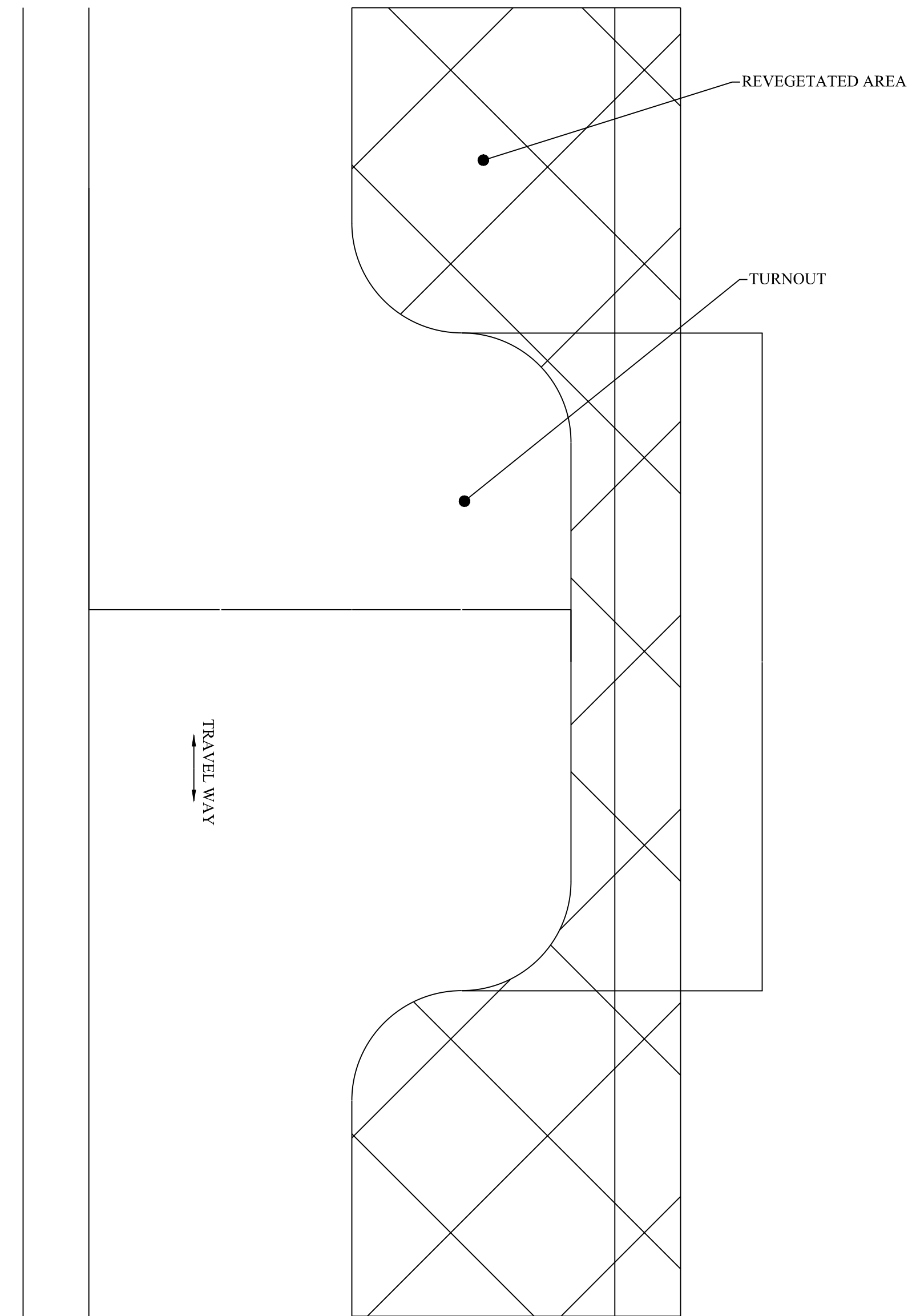

ROAD TURNOUT DETAIL
NOT TO SCALE

GENERAL NOTES:

1. SCALES NOTED ARE APPLICABLE TO FULL SIZE (24"x36") DRAWINGS ONLY. SCALE REDUCED DRAWINGS ACCORDINGLY.
2. NORTH AS SHOWN HEREON IS REFERENCED TO GRID NORTH, NAD83 MAINE STATE PLANES, WEST ZONE, US FOOT.
3. ELEVATIONS AS SHOWN HEREON ARE REFERENCED TO NAD 83.
4. EXISTING TOPOGRAPHIC AND PLANIMETRIC SURVEY INFORMATION AS SHOWN HEREON IS THE RESULT OF AERIAL TOPOGRAPHIC MAPPING COMPLETED BY PHOTOGRAMMETRIC TECHNOLOGY, INC. DEVELOPED FROM AERIAL PHOTOGRAPHY COMPLETED BY PHOTOGRAMMETRIC TECHNOLOGY, INC.
5. ENVIRONMENTAL RESOURCE MAPPING (WETLANDS, STREAMS, VERNAL POOLS, ETC.) AS SHOWN HEREON BY TETRA TECH.
6. INVERTS SHOWN ON PROPOSED CULVERTS MAY BE ADJUSTED BASED ON FIELD CONDITIONS.

No.	Revision/Issue	Date

PATRIOT RENEWABLES

ENGINEERING & MANAGEMENT SERVICES, INC.
345 SOUTH STREET, SUITE 100, WESTPORT, MAE 04091
 TEL: (817) 850-0000 FAX: (817) 850-0001

Stamp:



Drawing Title:
ACCESS AND CRANE ROAD REVEGETATION DETAILS AND NOTES

Date:	05/25/2021	Scale:	AS SHOWN
Drawn By:	GAD	Chk'd By:	RSC
Project:	WESTERN MAINE RENEWABLE ENERGY PROJECT		
Address:	MOSCOW, ME		
Client:	WESTERN MAINE RENEWABLES		
Sheet Number:	58 OF 62		

Desg No.:
C-409

GENERAL EROSION AND SEDIMENT CONTROL NOTES:

- ALL EROSION AND SEDIMENT CONTROL (ESC) MEASURES SHALL BE INSTALLED & MAINTAINED IN ACCORDANCE WITH THE MAINE EROSION AND SEDIMENT CONTROL BEST MANAGEMENT PRACTICES BY THE MAINE DEPARTMENT OF ENVIRONMENTAL PROTECTION DATED MARCH, 2003 (AS REVISED).
- THE CONTRACTOR SHALL BE RESPONSIBLE FOR CONDUCTING STORMWATER MANAGEMENT PRACTICES IN ACCORDANCE WITH LOCAL REGULATIONS AND GOVERNING AUTHORITIES AND SHALL BE RESPONSIBLE FOR ANY FINES RESULTING FROM EROSION CONTROL VIOLATIONS.
- THE CONTRACTOR SHALL PROVIDE PROPER EROSION AND SEDIMENT CONTROL MEASURES IN ALL AREAS OF WORK. PRIOR TO BEGINNING GRUBBING WORK, SEDIMENT BARRIERS SHALL BE INSTALLED. EROSION CONTROL MEASURES SHOWN ON THE DRAWINGS ARE A MINIMUM. CONTRACTOR SHALL TAKE ALL OTHER NECESSARY MEASURES TO CONTROL EROSION. EROSION CONTROL MEASURES SHALL ALSO BE INSTALLED AT THE DOWNGRADIENT PERIMETER OF THE TOPSOIL STOCKPILES. ALL DISTURBED EARTH SURFACES SHALL BE STABILIZED IN THE SHORTEST PRACTICAL TIME AND TEMPORARY EROSION CONTROL DEVICES SHALL BE EMPLOYED UNTIL SUCH TIME AS ADEQUATE SOIL STABILIZATION HAS BEEN ACHIEVED. TEMPORARY STORAGE OF EXCAVATED MATERIAL SHALL BE STABILIZED IN A MANNER THAT WILL MINIMIZE EROSION.
- THE CONTRACTOR SHALL INSPECT ESC MEASURES ONCE EVERY SEVEN DAYS AND WITHIN 24 HOURS OF SIGNIFICANT RAINFALL EVENTS, INCLUDING THOSE THAT RESULT IN DISCHARGE OF STORMWATER FROM THE SITE. SIGNIFICANT RAINFALL IS DEFINED AS RAINFALL OF HALF-INCH OR GREATER. REPAIRS SHALL BE MADE AS DIRECTED BY THE MAINE DEP'S ENVIRONMENTAL INSPECTOR AS NECESSARY. ACCUMULATED SEDIMENT TRAPPED BY ESC DEVICES SHALL BE REMOVED AS NECESSARY.
- THE ROAD WILL BE CONSTRUCTED IN SEGMENTS. EACH SEGMENT SHALL NOT EXCEED AN AREA THAT CANNOT BE STABILIZED WITHIN ONE WEEK.
- TEMPORARY EROSION AND SEDIMENT CONTROL DEVICES SHALL BE REMOVED AND THOSE ADJACENT AREAS RESTORED UPON COMPLETION OF THE WORK OR WHEN SO ORDERED BY THE ENGINEER OR MAINE DEP. EXPOSED SOIL RESULTING FROM REMOVAL OF TEMPORARY ESC MEASURES SHALL BE RAKED SEEDED, AND MULCHED OR MATTED AS NEEDED.
- TEMPORARY MULCHING IS TO BE APPLIED TO ALL DISTURBED AREAS WITHIN 21 DAYS OF INITIAL DISTURBANCE AND TO AREAS LEFT INACTIVE AND UNSTABILIZED FOR A PERIOD GREATER THAN 7 DAYS AT A RATE OF 2 TONS/ACRE UNLESS:
 - STABILIZATION IS NOT REQUIRED IF WORK IS TO CONTINUE IN THE AREA WITHIN THE NEXT 24 HOURS AND THERE IS NO PRECIPITATION FORECAST FOR THE NEXT 24 HOURS.
 - STABILIZATION IS NOT REQUIRED IF THE WORK IS OCCURRING IN A SELF-CONTAINED EXCAVATION (i.e. NO OUTLET) WITH A DEPTH OF 2 FEET OF GREATER (e.g. UTILITY TRENCHES)
- PERMANENT SEED MIX SHALL BE USED AS EARLY AS PRACTICABLE BETWEEN MAY 15TH AND SEPTEMBER 15TH AND MEET THE FOLLOWING MAINE DOT STANDARD SPECIFICATION 717.03 METHOD #2 CRITERIA:

RED FESCUE	50%
SHEEP FESCUE	25%
RED TOP	5%
WHITE CLOVER	10%
ANNUAL RYE	10%
- PERMANENT SEED MIX SHALL BE USED BETWEEN SEPTEMBER 15TH AND MAY 15TH AND SHALL MEET THE FOLLOWING CRITERIA:

WINTER RYE	80%
RED FESCUE	10%
SHEEP FESCUE	5%
RED TOP	1%
WHITE CLOVER	2%
ANNUAL RYE	2%
- CROWN VETCH CAN BE ADDED TO SEEDING MIXES AT 25%. CROWN VETCH IS NOT TO BE USED IN WETLAND AREAS
- WETLAND SEED MIX SHALL MEET THE FOLLOWING CRITERIA:

NODDING BUR MARI GOLD	3%
FOX SEDGE	13%
CREEPING BENTGRASS	14%
RIVERBANK WILD RYE	8%
VIRGINIA WILD RYE	14%
SOFT RUSH	2%
SENSITIVE FERN	1.5%
BLUE VERNAIN	1%
BLACKWELL SWITCH GRASS	2.5%
GREY DOGWOOD	0.5%
CREEPING RED FESCUE	18%
- THE METHOD OF STRIPPING VEGETATION SHALL BE SUCH AS TO MINIMIZE EROSION. FILLS SHALL BE PLACED AND COMPACTED IN SUCH A MANNER AS NOT TO DIVERT WATER ON TO ADJOINING PROPERTY.
- ANCHORED MULCH OR EROSION CONTROL BLANKET SHALL BE USED TO STABILIZE SLOPES BETWEEN 2H:1V AND 1H:1V.
- RIPRAP SHALL BE USED TO STABILIZE SLOPES BETWEEN 1H:1V AND 1H:1.5V OR SLOPES WHERE A HIGH WATER TABLE IS PRESENT.
- GEOSYNTHETIC BERMS AND EROSION CONTROL MIX BERMS MAY BE SUBSTITUTED FOR SILT FENCE BY THE CONTRACTOR AS CONDITIONS DICTATE.
- INITIAL CLEARING WILL CONSIST OF CLEARING 5 +/- FEET OF THE CUT AND FILL SLOPES. FURTHER CLEARING FOR EROSION CONTROL MEASURES WILL BE EVALUATED IN THE FIELD AND WILL BE WITHIN THE CLEARING LIMITS SPECIFIED ON THE PLAN.

WINTER CONSTRUCTION NOTES:

- THE CONTRACTOR SHALL BE RESPONSIBLE FOR COMPLETING ALL WINTER EROSION AND SEDIMENT CONTROL IN ACCORDANCE WITH SECTION A-3 OF "MAINE EROSION AND SEDIMENTATION BMP'S".
- WINTER EXCAVATION AND EARTHWORK SHALL BE COMPLETED SUCH THAT FOR ANY GIVEN SEGMENT OF THE PROJECT AREA, NO MORE THAN ONE ACRE WILL BE EXPOSED AT ANY GIVEN TIME.
- DISTURBED AREAS ARE TO BE LIMITED TO AREAS WHERE WORK IS TO BE COMPLETED WITHIN 15 DAYS AND CAN BE MULCHED IN ONE DAY PRIOR TO A SNOW EVENT.
- AREAS OF DISTURBED SOIL SHALL BE STABILIZED AT THE END OF EACH WORK DAY, WITH THE FOLLOWING EXCEPTIONS: (1) IF NO RUNOFF EVENT IS FORECAST FOR WITHIN 24 HOURS AND WORK WILL RESUME IN THE SAME DISTURBED AREA WITHIN 24 HOURS AND/OR (2) DISTURBED AREAS THAT COLLECT AND RETAIN RUNOFF, SUCH AS OPEN UTILITY TRENCHES OR FOUNDATIONS, WHICH REQUIRE STABILIZATION AT THE END OF EACH WEEK.
- SNOW PILING SHALL OCCUR WITHIN THE DESIGNATED LIMITS OF DISTURBANCE.
- DRAINAGE STRUCTURES SHALL BE KEPT OPEN AND FREE OF SNOW AND ICE DAMS.
- SILT FENCE AND OTHER PRACTICES REQUIRING EARTH DISTURBANCE SHALL BE INSTALLED PRIOR TO FROZEN GROUND CONDITIONS. SILT FENCE MAY BE INSTALLED WITH STONE BACKING DURING FROZEN GROUND CONDITIONS.
- MULCH USED FOR TEMPORARY STABILIZATION SHALL BE APPLIED AT 4 TONS/ACRE WITH AN 80 TO 90 PERCENT UNIFORM COVER AND TRACKED IN TO PREVENT REMOVAL BY WIND.
- PRIOR TO STABILIZATION, SNOW AND/OR ICE SHALL BE REMOVED TO LESS THAN ONE INCH REMAINING.
- TEMPORARY CONSTRUCTION ENTRANCES SHALL BE INSTALLED AND MAINTAINED AT LOCATIONS WHERE CONSTRUCTION VEHICLE TRAFFIC WILL BE ENTERING AND LEAVING THE CONSTRUCTION SITE. ENTRANCES SHALL BE AT LEAST 14 FEET WIDE TO ACCOMMODATE VEHICULAR TRAFFIC.
- ALL SLOPES LESS THAN 3H:1V SHALL BE MULCHED AT 4 TONS/ACRE AND TRACKED IN.
- THE SITE STABILIZATION SCHEDULE BEFORE WINTERS SHALL BE AS FOLLOWS:

SEPTEMBER 15	ALL DISTURBED AREAS MUST BE SEEDED AND MULCHED. ALL SLOPES REQUIRING VEGETATION MUST BE STABILIZED, SEEDED, AND MULCHED.
OCTOBER 1	ALL DISTURBED AREAS TO BE PROTECTED WITH AN ANNUAL GRASS MUST BE SEEDED AT A SEEDING RATE OF 3 POUNDS PER 1000 SQ-FT AND MULCHED.
NOVEMBER 15	ALL STONE-LINED DITCHES AND CHANNELS MUST BE CONSTRUCTED AND STABILIZED. ALL SLOPES REQUIRING RIPRAP MUST BE CONSTRUCTED.
DECEMBER 1	ALL DISTURBED AREAS WHERE THE GROWTH OF VEGETATION FAILS TO BE AT LEAST THREE INCHES TALL OR AT LEAST 75% OF THE DISTURBED SOIL IS COVERED BY VEGETATION, MUST BE PROTECTED FOR OVER-WINTER.

EROSION CONTROL MIX BERM DETAIL

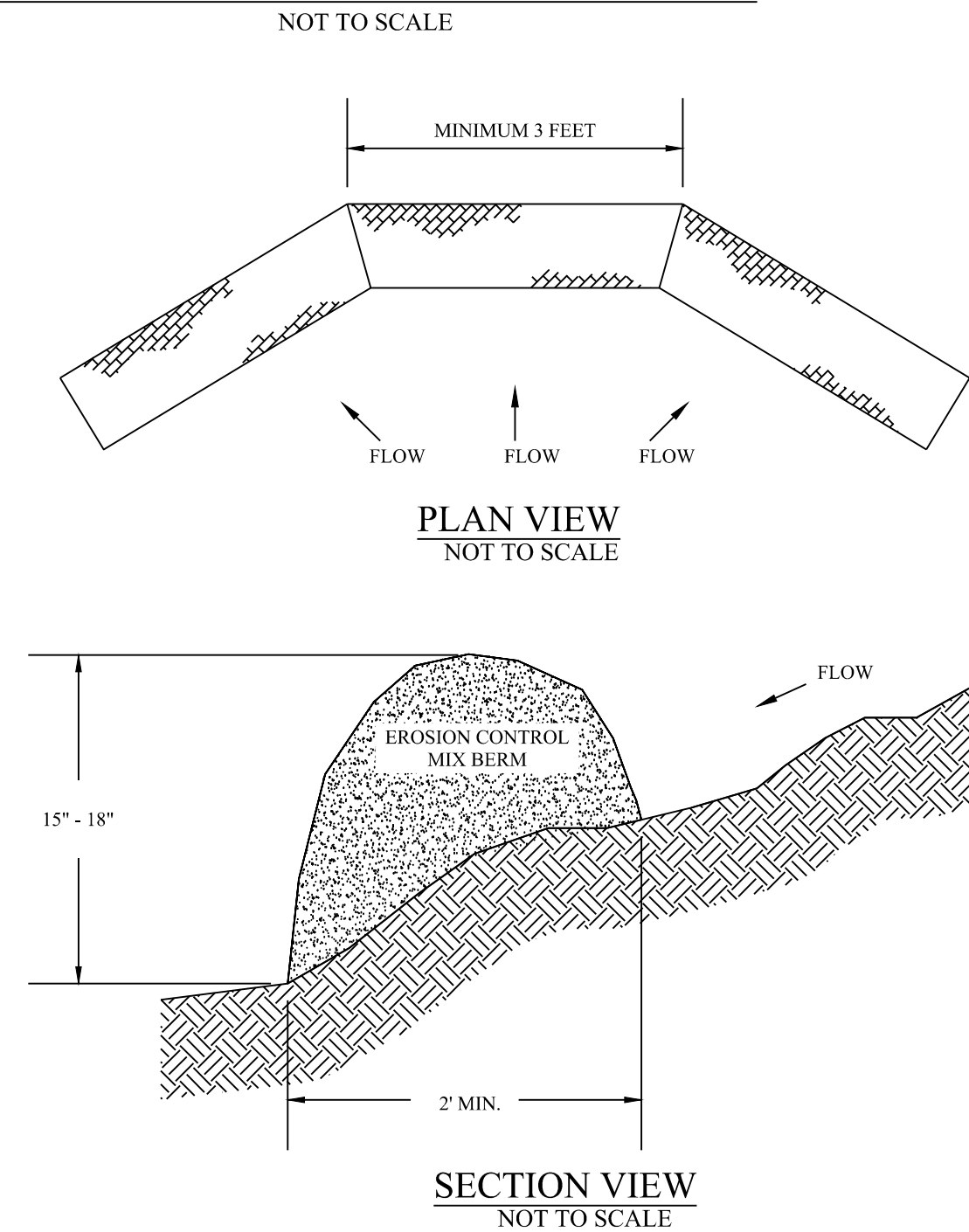

NOTES:
 1. EROSION CONTROL MIX SHALL CONTAIN A WELL-GRADED MIXTURE OF STUMP GRINDINGS OR SIMILAR COARSE, FIBROUS ORGANIC MATERIAL WITH A RANGE OF SIZES AND MAY CONTAIN ROCKS LESS THAN 4-INCHES IN DIAMETER. EROSION CONTROL MIX MUST BE FREE OF REFUSE PHYSICAL CONTAMINANTS, AND MATERIALS TOXIC TO PLANT GROWTH. THE MIX COMPOSITION SHALL MEET THE FOLLOWING STANDARDS.

- THE ORGANIC MATTER CONTENT SHALL BE BETWEEN 20 AND 100 PERCENT, DRY WEIGHT BASIS.
- PARTICLE SIZE BY WEIGHT SHALL BE 100 PERCENT PASSING A 6-INCH SCREEN AND 70 PERCENT TO 85 PERCENT, PASSING A 3/4-INCH SCREEN.
- THE ORGANIC PORTION NEEDS TO BE FIBROUS AND ELONGATED.
- LARGE PORTIONS OF SILTS, CLAYS, OR FINE SANDS ARE NOT ACCEPTABLE IN THE MIX.
- THE BARRIER MUST BE PLACED ALONG A RELATIVELY LEVEL CONTOUR. TALL GRASSES MAY NEED TO BE CUT TO AVOID VOID SPACES THAT WOULD ALLOW FINES TO WASH UNDER THE BARRIER.
- FROZEN GROUND, OUTCROPS OF BEDROCK AND VERY ROOTED FORESTED AREAS ARE LOCATIONS WHERE BERMS OF EROSION CONTROL MIX ARE MOST PRACTICAL AND EFFECTIVE.
- THE EROSION CONTROL MIX CAN BE CONTAINED WITHIN A SYNTHETIC TUBULAR NETTING OR "SOCK". REFER TO GEOSYNTHETIC BERM BELOW.

GEOSYNTHETIC BERM DETAIL

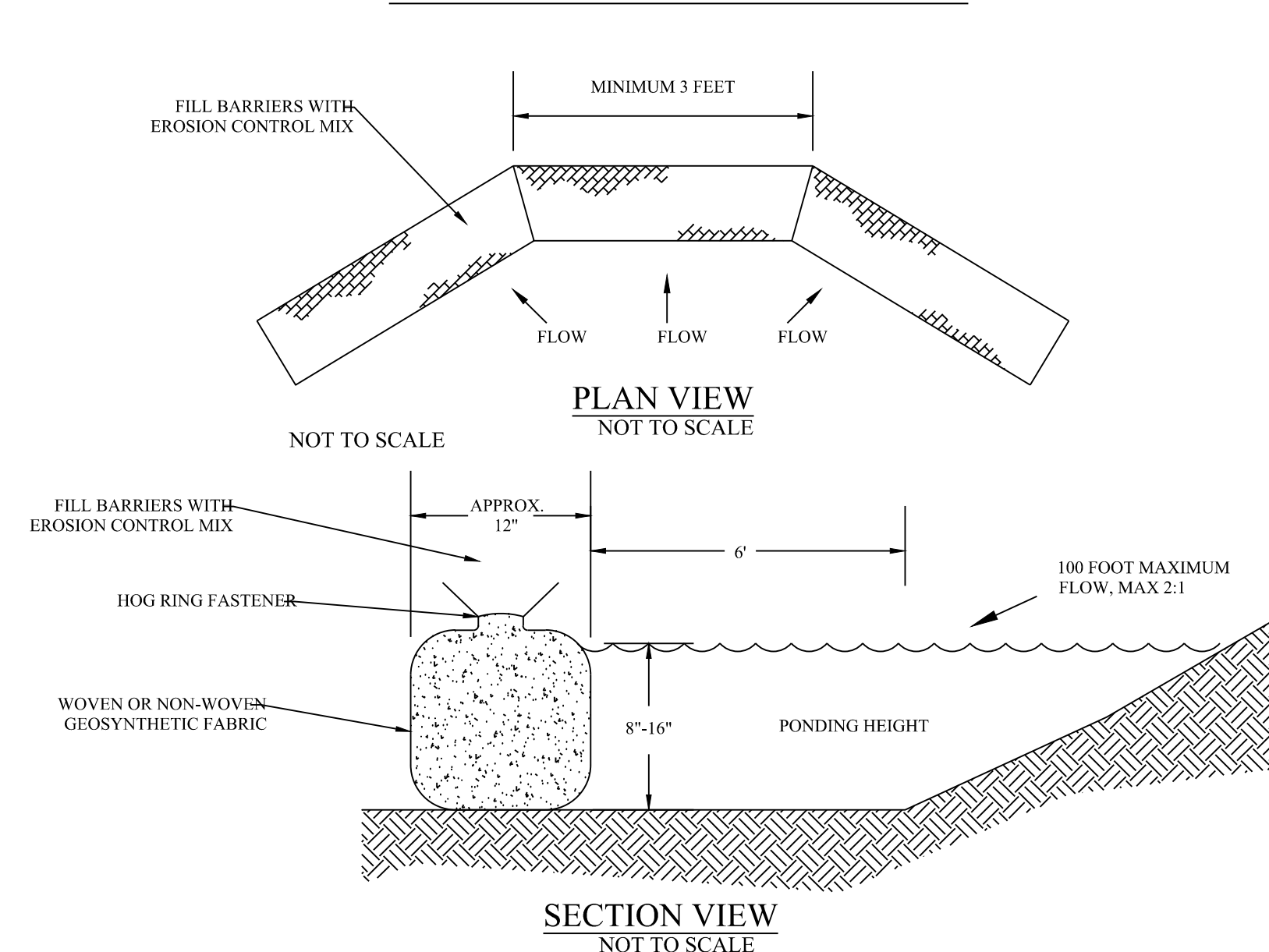

NOTES:
 1. EROSION CONTROL MIX SHALL CONTAIN A WELL-GRADED MIXTURE OF PARTICLE SIZE AND MAY CONTAIN ROCKS LESS THAN 4-INCHES IN DIAMETER. EROSION CONTROL MIX MUST BE FREE OF REFUSE, PHYSICAL CONTAMINANTS, AND MATERIAL TOXIC TO PLANT GROWTH. THE MIX COMPOSITION SHALL MEET THE FOLLOWING STANDARDS.

- THE ORGANIC MATTER CONTENT SHALL BE BETWEEN 80 AND 100 PERCENT, DRY, WEIGHT BASIS.
- PARTICLE SIZE BY WEIGHT SHALL BE 100 PERCENT PASSING A 6-INCH SCREEN AND A MINIMUM OF 70 PERCENT, MAXIMUM OF 85 PERCENT, PASSING A 3/4-INCH SCREEN.
- THE ORGANIC PORTION NEEDS TO BE FIBROUS AND ELONGATED.
- LARGE PORTIONS OF SILTS, CLAYS, OR FINE SANDS ARE NOT ACCEPTABLE IN THE MIX.
- SUITABLE SALTS CONTENT SHALL BE LESS THAN 4.0.
- THE BARRIER MUST BE PLACED ALONG A RELATIVELY LEVEL CONTOUR. TALL GRASSES MAY NEED TO BE CUT TO AVOID SPACES THAT WOULD ALLOW FINES TO WASH UNDER THE BARRIER.
- FROZEN GROUND, OUTCROPS OF BEDROCK, AND VERY ROOTED FORESTED AREAS ARE LOCATIONS WHERE BERMS OF EROSION CONTROL MIX ARE MOST PRACTICAL AND EFFECTIVE.

GENERAL NOTES:

- SCALES NOTED ARE APPLICABLE TO FULL SIZE (24"x36") DRAWINGS ONLY. SCALE REDUCED DRAWINGS ACCORDINGLY.
- NORTH AS SHOWN HEREON IS REFERENCED TO GRID NORTH, NAD83 MAINE STATE PLANES, WEST ZONE, US FOOT.
- ELEVATIONS AS SHOWN HEREON ARE REFERENCED TO NAD 83.
- EXISTING TOPOGRAPHIC AND PLANIMETRIC SURVEY INFORMATION AS SHOWN HEREON IS THE RESULT OF AERIAL TOPOGRAPHIC MAPPING COMPLETED BY PHOTOGRAMMETRIC TECHNOLOGY, INC. DEVELOPED FROM AERIAL PHOTOGRAPHY COMPLETED BY PHOTOGRAMMETRIC TECHNOLOGY, INC.
- ENVIRONMENTAL RESOURCE MAPPING (WETLANDS, STREAMS, VERNAL POOLS, ETC.) AS SHOWN HEREON BY TETRA TECH.
- INVERTS SHOWN ON PROPOSED CULVERTS MAY BE ADJUSTED BASED ON FIELD CONDITIONS.

No.	Revision/Issue	Date
-----	----------------	------

PATRIOT RENEWABLES

 ENGINEERING & MANAGEMENT SERVICES, INC.
565 SOUTH STREET, SUITE 100, WILTON, NH 03095
 TEL: (603) 850-0000 FAX: (603) 850-0005

Stamp:

Drawing Title:
EROSION AND SEDIMENT CONTROL DETAILS AND NOTES

Date:	05/25/2021	Scale:	AS SHOWN
Drawn By:	GAD	Chk'd By:	RSC
Project:	WESTERN MAINE RENEWABLE ENERGY PROJECT		
Address:	MOSCOW, ME		
Client:	WESTERN MAINE RENEWABLES		
Sheet Number:	59 OF 62		

Dwg No.:
C-410

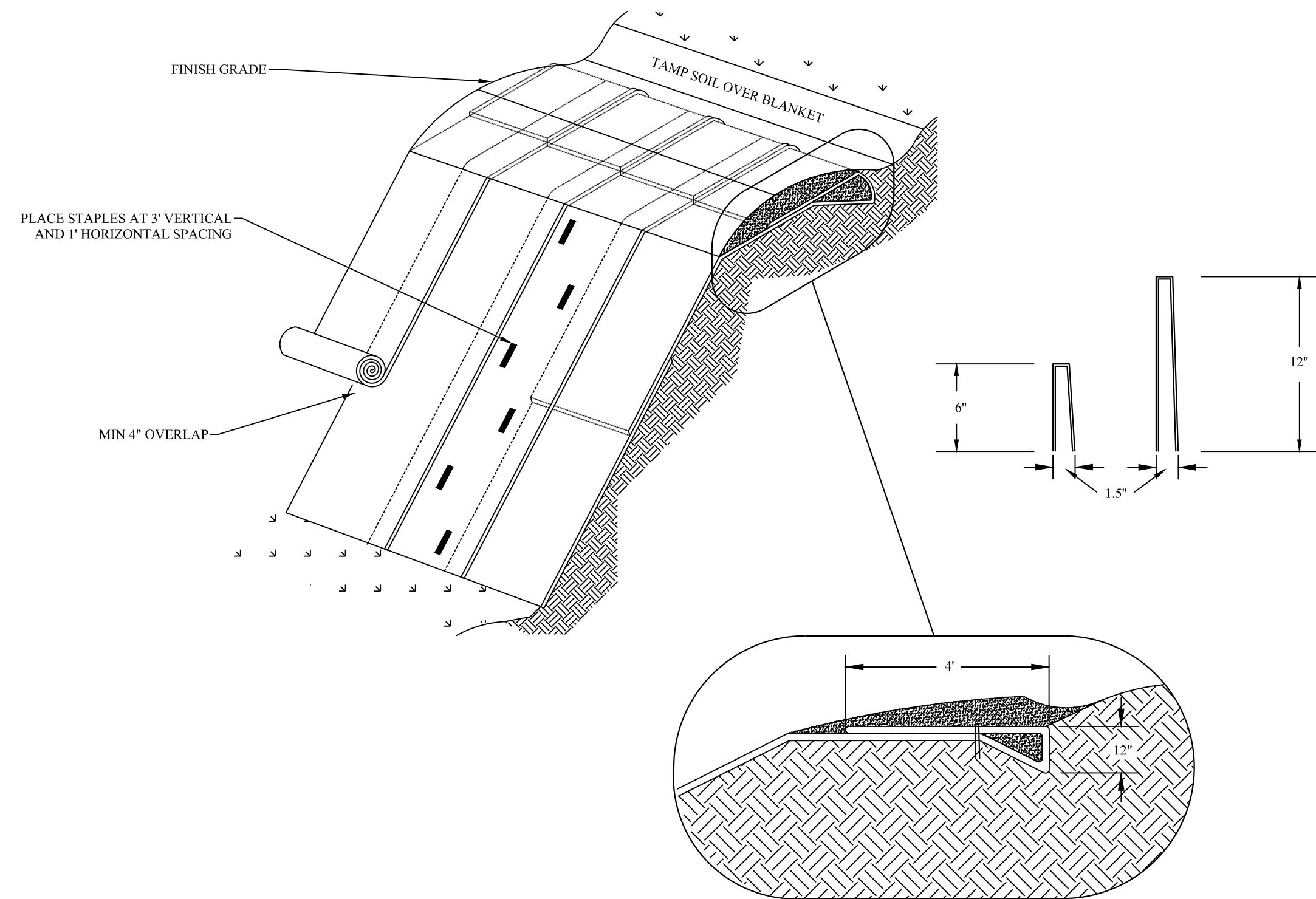

- NOTES:**
1. SLOPE SURFACE SHALL BE FREE OF ROCKS, CLODS, STICKS, AND GRASS. BLANKETS SHALL HAVE GOOD SOIL CONTACT.
 2. APPLY PERMANENT SEEDING BEFORE PLACING BLANKETS.
 3. LAY BLANKETS LOOSELY AND STAKE OR STAPLE OR MAINTAIN DIRECT CONTACT WITH THE SOIL. DO NOT STRETCH.
 4. INSTALL BLANKETS WITH OVERLAPPING SEAMS RUNNING VERTICALLY DOWNSLOPE.

EROSION CONTROL BLANKET DETAIL (SLOPE)
NOT TO SCALE

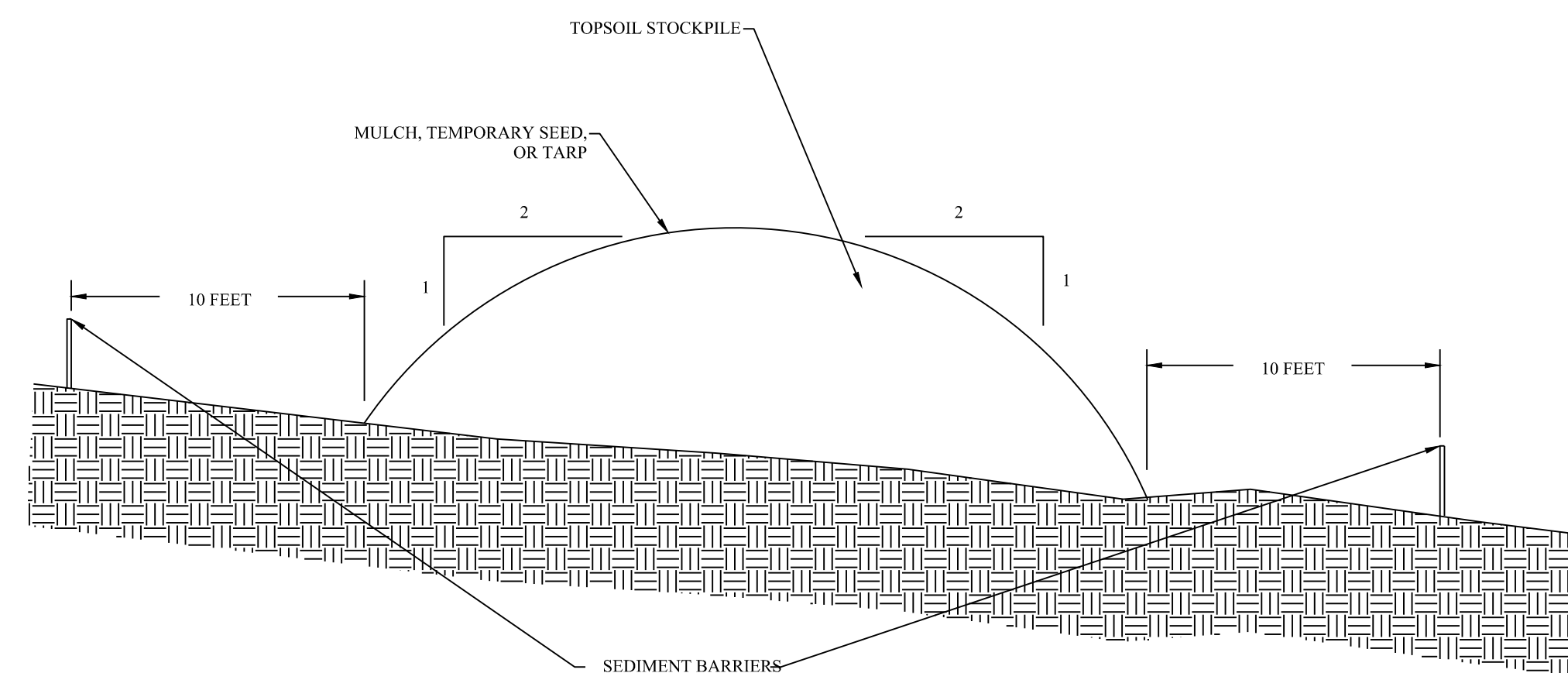

- NOTES:**
1. A SEDIMENT BARRIER SHALL SURROUND ALL TOPSOIL STOCKPILES.
 2. TOPSOIL STOCKPILES SHALL NOT OBSTRUCT WITH NATURAL DRAINAGE.
 3. TOPSOIL STOCKPILES MUST BE MULCHED, TEMPORARILY SEEDED, OR TARPPED.
 - 3.1. TEMPORARY SEEDING OF TOPSOIL STOCKPILES MUST TAKE PLACE WITHIN 7 DAYS OF THE FORMATION OF THE STOCKPILE
 - 3.2. IN CRITICAL AREAS (NEAR LAKES, STREAMS, OR WETLANDS) TEMPORARY SEEDING SHALL BE COMPLETED WITHIN 24 HOURS.
 4. SIDESLOPES OF TOPSOIL STOCKPILES SHALL NOT EXCEED 2H:1V.
 5. WETLAND SOILS SHALL BE STOCKPILED SEPARATELY FROM UPLAND SOILS.

TOPSOIL STOCKPILE DETAIL
NOT TO SCALE

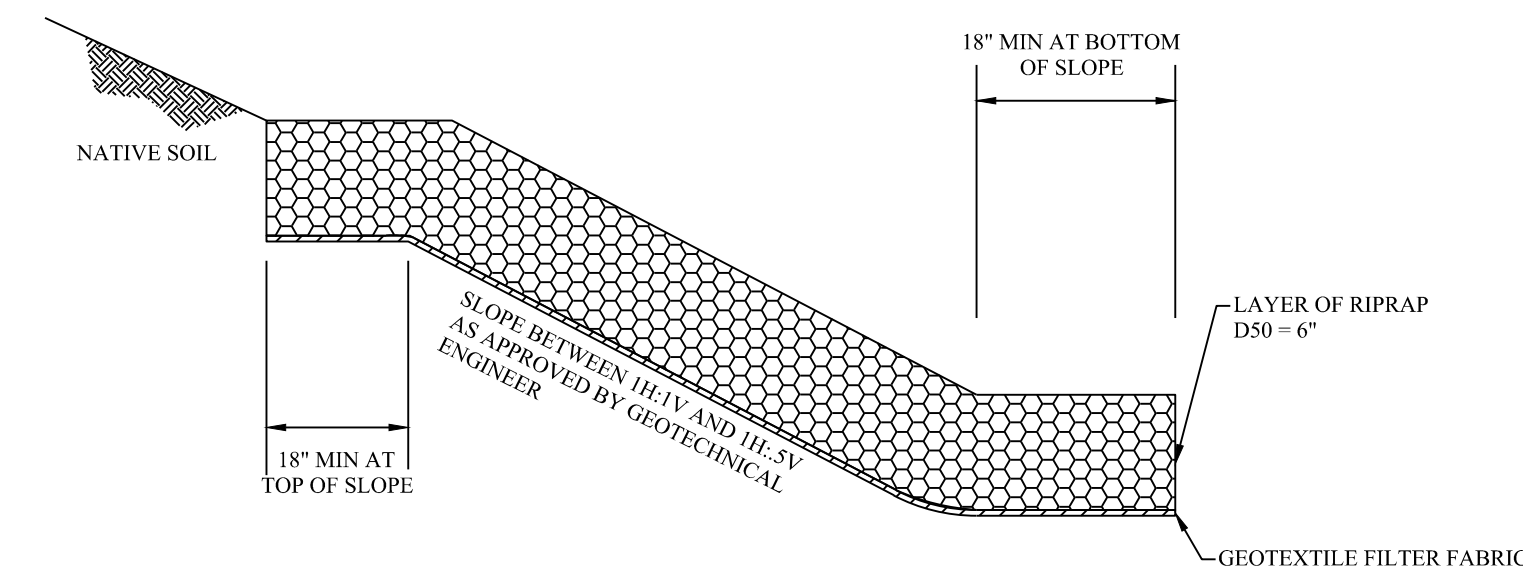

RIPRAP SLOPE STABILIZATION DETAIL
NOT TO SCALE

TRANSMISSION LINE CONSTRUCTION NOTES:

1. THE FOLLOWING MEANS AND METHODS ARE TO BE EMPLOYED DURING THE CONSTRUCTION OF THE TRANSMISSION LINE. THE PROPER TECHNIQUE WILL BE DETERMINED BASED ON THE CONDITIONS IN THE FIELD AFTER CONSULTATION WITH THE ENGINEER AND THIRD PARTY INSPECTOR.
2. IF CONSTRUCTION CANNOT BE COMPLETED WHILE THE GROUND IS FROZEN, TIMBER MATS SHOULD BE USED IN WETLANDS.
3. IN AREAS SHOWING A HIGH GROUND WATER TABLE OR WHERE HIGH WATER TABLE IS SUSPECTED, TIMBER MATTING CAN BE USED TO AVOID DAMAGING THE EXISTING SURFACE.
4. IN AREAS WHERE THERE IS A HIGH POSSIBILITY OF EROSION, EROSION CONTROL BARRIERS SHOULD BE INSTALLED.
5. IF UNDERDRAINAGE IS OPENED DURING THE COURSE OF CONSTRUCTION, SLASH CAN BE USED TO SEAL THE RUT.
6. ANY AREA THAT IS DAMAGED DURING CONSTRUCTION MUST BE RESTORED UPON COMPLETION.
7. IF RUTTING OCCURS AT THE ENTRANCES TO THE TIMBER MAT STRUCTURE, EROSION CONTROL MIX BERMS SHOULD BE INSTALLED AS SHOWN BELOW.

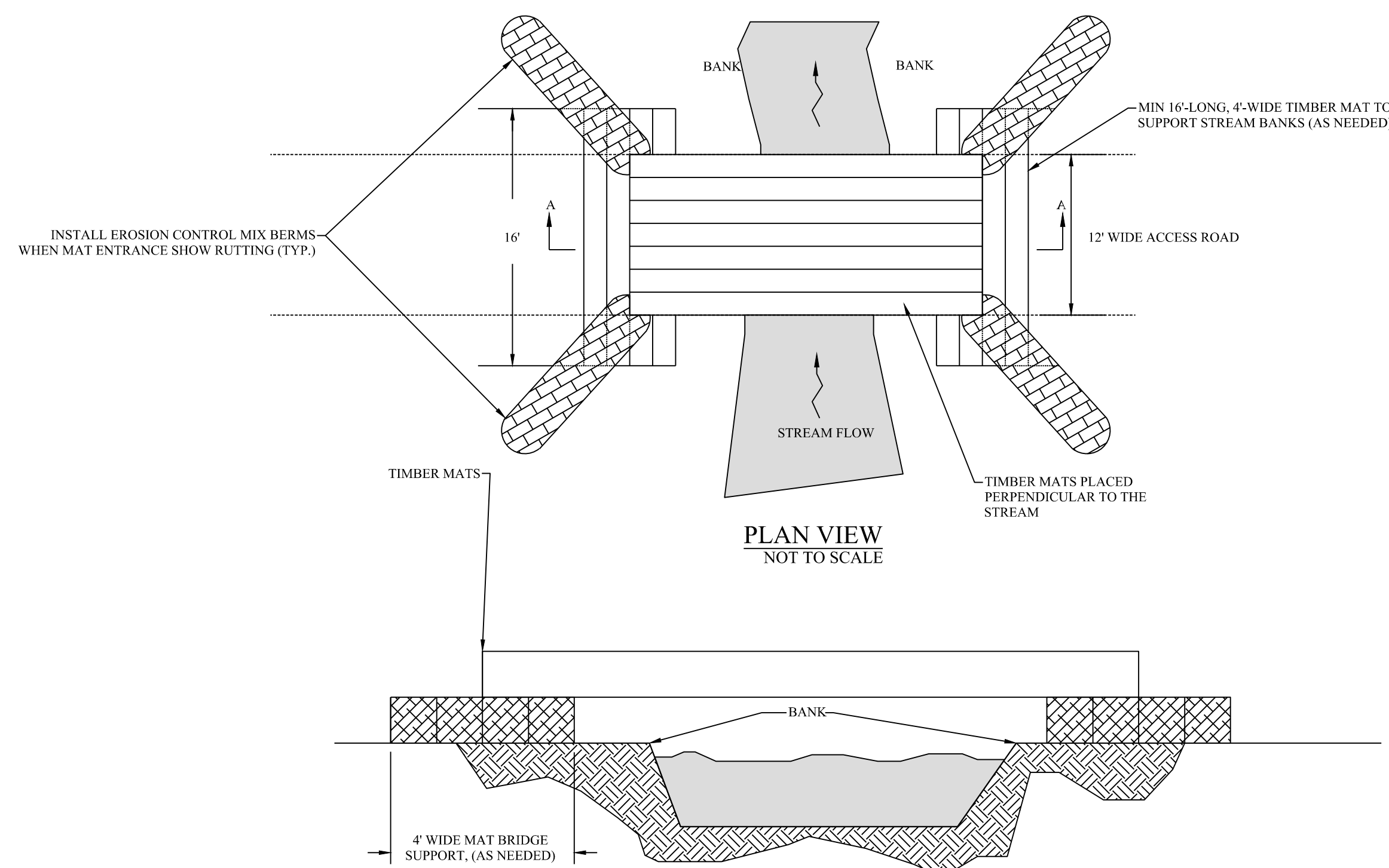

- NOTES:**
1. DEPLOY EROSION CONTROLS AS NEEDED TO MINIMIZE EROSION.
 2. PERFORM ROUTINE INSPECTION TO INCLUDE REMOVAL OF LOOSE SOIL TRACKED ONTO BRIDGE BY EQUIPMENT AND INSPECTION OF STREAM BANKS FOR STABILITY
 3. MATS SHALL BE POSITIONED TO MAINTAIN THE NATURAL STREAM CHARACTERISTICS.
 4. MATS LAID PERPENDICULAR TO THE STREAM CAN BE SUBSTITUTED WITH PRE-FABRICATED BRIDGE STRUCTURES AS SPAN LENGTHS DICTATE OR AT THE PREFERENCE OF THE CONTRACTOR.
 5. A MINIMUM BRIDGE WIDTH OF 16' SHALL BE USED DURING TIMBER REMOVAL ACTIVITIES.
 6. BRIDGES USED FOR MULTIPLE CROSSINGS AND LONG TERM USE SHALL BE INSTALLED WITH FABRIC, SECONDARY DECKING, AND SIDE BOARDS.
 7. IF RUTTING OCCURS AT THE ENTRANCES TO THE TIMBER MAT STRUCTURE, EROSION CONTROL MIX BERMS SHOULD BE INSTALLED AS SHOWN ABOVE..

TYPICAL "MAT" BRIDGE FOR TEMPORARY STREAM CROSSING
NOT TO SCALE

GENERAL NOTES:

1. SCALES NOTED ARE APPLICABLE TO FULL SIZE (24"x36") DRAWINGS ONLY. SCALE REDUCED DRAWINGS ACCORDINGLY.
2. NORTH AS SHOWN HEREON IS REFERENCED TO GRID NORTH, NAD83 MAINE STATE PLANES, WEST ZONE, US FOOT.
3. ELEVATIONS AS SHOWN HEREON ARE REFERENCED TO NAD 83.
4. EXISTING TOPOGRAPHIC AND PLANIMETRIC SURVEY INFORMATION AS SHOWN HEREON IS THE RESULT OF AERIAL TOPOGRAPHIC MAPPING COMPLETED BY PHOTOGRAMMETRIC TECHNOLOGY, INC. DEVELOPED FROM AERIAL PHOTOGRAPHY COMPLETED BY PHOTOGRAMMETRIC TECHNOLOGY, INC.
5. ENVIRONMENTAL RESOURCE MAPPING (WETLANDS, STREAMS, VERNAL POOLS, ETC.) AS SHOWN HEREON BY TETRA TECH.
6. INVERTS SHOWN ON PROPOSED CULVERTS MAY BE ADJUSTED BASED ON FIELD CONDITIONS.

No.	Revision/Issue	Date

PATRIOT RENEWABLES

EMS

ENGINEERING & MANAGEMENT SERVICES, INC.

565 SOUTH STREET, SUITE 100, WEST BURNFIELD, MA 01093
TEL: (817) 850-0000 FAX: (817) 850-0005

Stamp:

EROSION AND SEDIMENT CONTROL DETAILS AND NOTES

Date: 05/25/2021	Scale: AS SHOWN
Drawn By: GAD	Chk'd By: RSC
Project: WESTERN MAINE RENEWABLE ENERGY PROJECT	
Address: MOSCOW, ME	
Client: WESTERN MAINE RENEWABLES	
Sheet Number: 60 OF 62	

Dwg No.: **C-411**

C:\Users\jgibson\My ShareSync\Projects\Maine\Moscow\PROJECT SET\DETAILS.dwg

STREAM CROSSINGS DETAIL

NOT TO SCALE

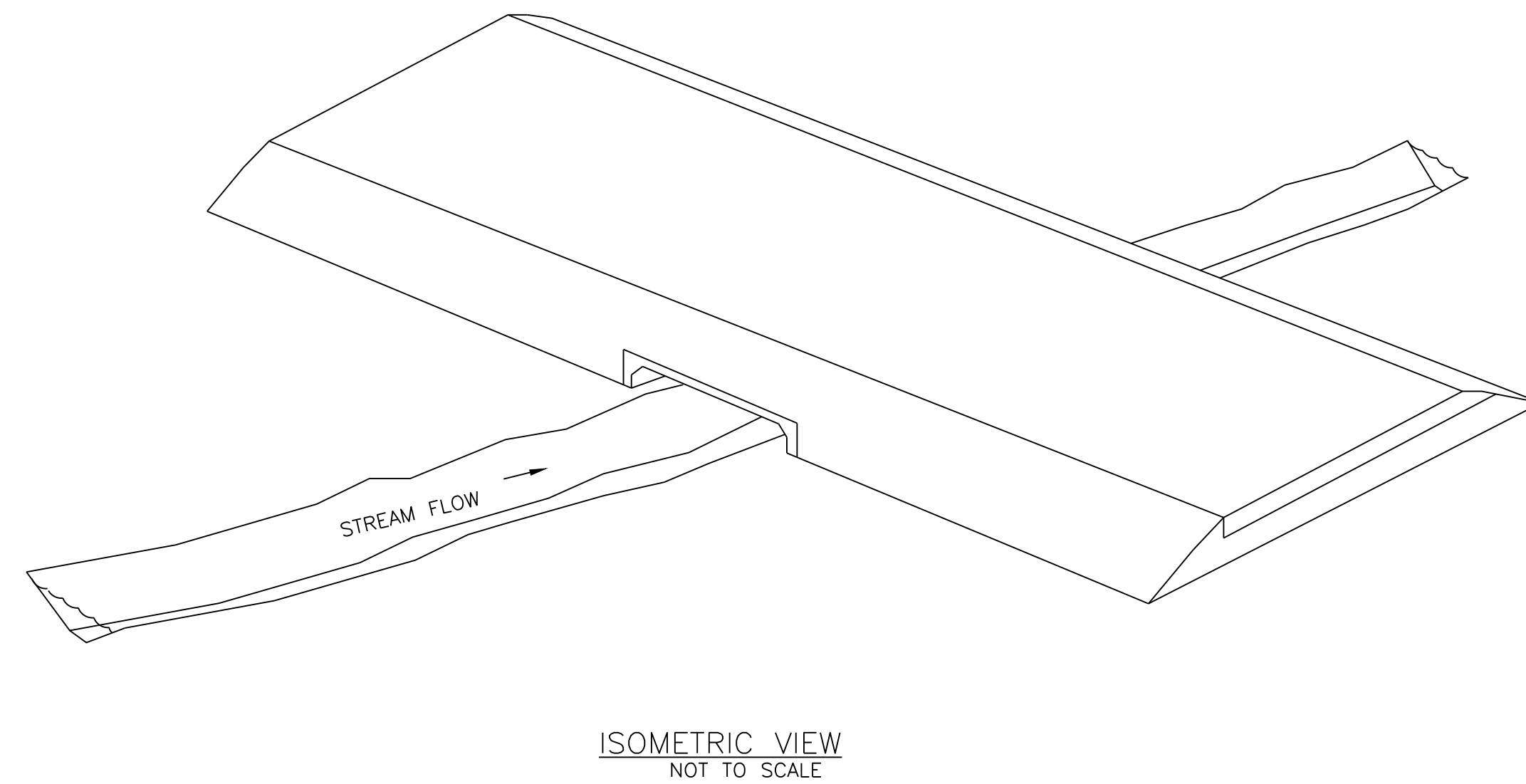
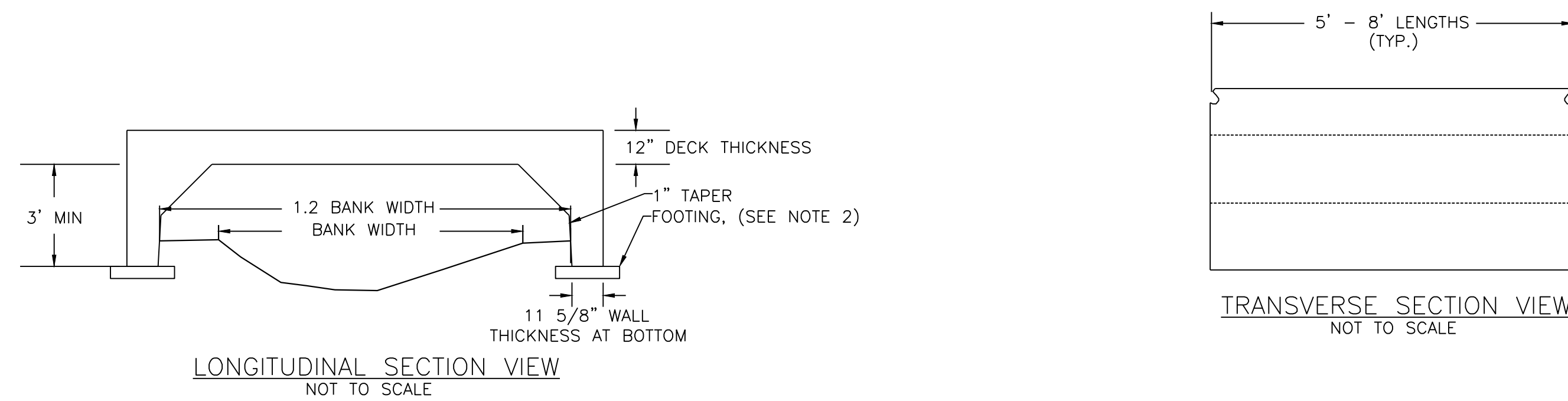

NOTES:

- CULVERT/BRIDGE STRUCTURE MUST PROVIDE AN OPENING WITH A CROSS-SECTIONAL AREA AT LEAST EQUAL TO 3 TIMES THE CROSS-SECTIONAL AREA OF THE STREAM CHANNEL OR SUFFICIENT IN SIZE TO ACCOMMODATE 25-YEAR FREQUENCY WATER FLOWS.
- CULVERT/BRIDGE STRUCTURE TO BE PRECAST OR MODULAR CONCRETE BLOCKS WITH PRECAST PANELS.
- CULVERT/BRIDGE STRUCTURE MUST BE INSTALLED IN A MANNER TO PREVENT EROSION OF MATERIAL INTO THE RIVER, STREAM OR BROOK.
- WHEELED OR TRACKED EQUIPMENT MAY NOT OPERATE IN THE WATER. EQUIPMENT OPERATING ON THE SHORE MAY, WHERE NECESSARY, REACH INTO THE WATER WITH A BUCKET OR SIMILAR EXTENSION. EQUIPMENT MAY CROSS STREAMS ON ROCK, GRAVEL OR LEDGE BOTTOM.
- IF THE CROSSING INVOLVES TRENCHING OR DISTURBANCE OF SUBSTRATE IN A RIVER, STREAM OR BROOK BETWEEN OCTOBER 2 AND JULY 14, THE ACTIVITY MUST OCCUR DURING THE TIME PERIOD APPROVED BY THE DEP. THE APPROVED TIME PERIOD MAY BE THE TIME PERIOD PROPOSED BY THE APPLICANT OR AN ALTERNATIVE TIME PERIOD APPROVED BY THE DEP. AN ALTERNATIVE TIME PERIOD WILL BE REQUIRED WHERE IT APPEARS AN UNREASONABLE IMPACT ON WATER QUALITY OR FISHERIES MAY RESULT AT THE POINT OF CROSSING OR IMMEDIATELY DOWNSTREAM OF THE CROSSING. THE APPLICANT WILL BE NOTIFIED BY THE DEP WITHIN 14 DAYS IF AN ALTERNATIVE TIME PERIOD, OTHER THAN THE ONE PROPOSED BY THE APPLICANT, IS REQUIRED FOR CONSTRUCTING THE CROSSING.
- ALL EXCAVATED MATERIAL MUST BE STOCKPILED EITHER OUTSIDE THE WETLAND OR ON MATS OR PLATFORMS.
- HAY BALES, SILT FENCE OR EROSION CONTROL MIX BERM MUST BE USED, WHERE NECESSARY, TO PREVENT SEDIMENTATION.
- SPECIAL CULVERT SECTION RESTS ON SMALL FOOTINGS, WHERE THE VENDOR OR CONTRACTOR DEEMS NEEDED.
- USE SPECIAL CULVERT SECTION FOR STREAMS OF SPECIAL INTEREST.
- HEIGHT AND TOTAL SPAN WILL VARY AT BRIDGE CROSSINGS.
- INTERIOR OF CULVERT TO BE CLEAR OF RIPRAP BACK FILL AND DEBRIS.

GENERAL NOTES:

- SCALES NOTED ARE APPLICABLE TO FULL SIZE (24"x36") DRAWINGS ONLY. SCALE REDUCED DRAWINGS ACCORDINGLY.
- NORTH AS SHOWN HEREON IS REFERENCED TO GRID NORTH, NAD83 MAINE STATE PLANES, WEST ZONE, US FOOT.
- ELEVATIONS AS SHOWN HEREON ARE REFERENCED TO NAD 83.
- EXISTING TOPOGRAPHIC AND PLANIMETRIC SURVEY INFORMATION AS SHOWN HEREON IS THE RESULT OF AERIAL TOPOGRAPHIC MAPPING COMPLETED BY PHOTOGRAMMETRIC TECHNOLOGY, INC. DEVELOPED FROM AERIAL PHOTOGRAPHY COMPLETED BY PHOTOGRAMMETRIC TECHNOLOGY, INC.
- ENVIRONMENTAL RESOURCE MAPPING (WETLANDS, STREAMS, VERNAL POOLS, ETC.) AS SHOWN HEREON BY TETRA TECH.
- INVERTS SHOWN ON PROPOSED CULVERTS MAY BE ADJUSTED BASED ON FIELD CONDITIONS.

No.	Revision/Issue	Date
-----	----------------	------

PATRIOT RENEWABLES

EMS
ENGINEERING & MANAGEMENT SERVICES, INC.
345 SOUTH STREET, SUITE 100, BRISTOL, ME 04015
TEL: (617) 850-0000 FAX: (617) 850-0005

Stamp:

Drawing Title:
CULVERT/ BRIDGE STRUCTURE DETAILS AND NOTES

Date:	Scale:
05/25/2021	AS SHOWN
Drawn By:	Chk'd By:
GAD	RSC
Project: WESTERN MAINE RENEWABLE ENERGY PROJECT	
Address: MOSCOW, ME	
Client: WESTERN MAINE RENEWABLES	
Sheet Number: 61 OF 62	

Dwg No.: **C-412**

Western Maine Renewable Energy Project

Stormwater Treatment Calculations:

Watersheds draining to the Kennebec River via Chase Chase Stream, Basset Brook, Austin Stream and Mink brook Chapter 500, Stormwater Management, Section 4.B.(3).(c) describes a linear project. Required stormwater treatment of impervious area = 75%

BMP ID Legend

RSF = Road side Forested buffer
 RSM = Road side Meadow buffer
 BF = Forested buffer adjacent to road/small impervious area
 BM = Meadow buffer adjacent to road/small impervious area
 LSF = Forested level lip spreader buffer
 LSM = Meadow level lip spreader buffer
 DTF = Forested Ditch Turnout
 DTM = Meadow Ditch Turnout

Road ID	Station Location			BMP ID	Soil HSG	Buffer Slope (ft./ft.)	Min. Flow Path Length (ft.)	Buffer or Stone Berm Length (ft.)	Impervious Area (acres)	Impervious Area Treated (acres)	
Access Road-1	00+00	to	07+50	-	-	-	-	-	0.207	0.000	
Access Road-1	07+50	to	19+25	R	RSM 03A	D	0.030	55	1175	0.324	0.324
Access Road-1	28+25	to	30+50	R	RSM 03B	D	0.030	55	225	0.062	0.062
Access Road-1	31+50	to	44+25	R	RSM 03C	D	0.030	55	1275	0.351	0.351
Access Road-1	44+25	to	44+50	-	-	-	-	-	0.007	0.000	
Access Road-2	00+00	to	02+25	-	-	-	-	-	0.062	0.000	
Access Road-2	02+25	to	13+50	R	LSF 02	C	0.022	100	67	0.310	0.310
Access Road-2	13+50	to	15+00	R	RSF 01	C	0.015	35	170	0.041	0.041
Access Road-2	15+00	to	16+25	-	-	-	-	-	0.034	0.000	
Access Road-2	16+25	to	19+75	R	RSM 01	C	0.021	55	300	0.096	0.096
Access Road-2	19+75	to	22+50	R	RSF 02	C	0.035	35	300	0.076	0.076
Access Road-2	22+50	to	24+25	-	-	-	-	-	0.048	0.000	
Access Road-2	24+25	to	26+00	R	LSF 01	C	0.025	100	125	0.048	0.048
Access Road-3	00+00	to	16+50	-	-	-	-	-	0.455	0.000	
Access Road-3	16+50	to	23+00	L	LSF 04	D	0.093	150	107	0.179	0.179
Access Road-3	23+00	to	26+50	L	RSF 04	D	0.073	35	360	0.096	0.096
Access Road-3	26+50	to	28+50	R	BF 04	D	0.143	180	209	0.055	0.055
Access Road-3	28+50	to	32+00	R	RSF 05	D	0.122	35	335	0.096	0.096
Access Road-3	32+00	to	40+50	R	LSF 05	C	0.079	100	93	0.234	0.234
Access Road-3	40+50	to	59+50	-	-	-	-	-	0.523	0.000	
Access Road-3	59+50	to	63+50	L	LSF 06	C	0.142	100	129	0.110	0.110
Access Road-3	63+50	to	67+50	-	-	-	-	-	0.110	0.000	
Access Road-3	67+50	to	73+50	L	LSM 01	C	0.122	150	203	0.158	0.158
Access Road-3	73+50	to	84+00	L	LSM 02	C	0.135	150	135	0.289	0.289
Access Road-3	84+00	to	87+50	L	RSF 06	C	0.105	35	265	0.096	0.096
Access Road-3	87+50	to	93+00	-	-	-	-	-	0.152	0.000	
Radar Tower 1 Access	00+00	to	01+00	-	BF 05	C/D	0.011	150	150	0.046	0.046
Radar Tower 2 Access	00+00	to	02+50	-	-	-	-	-	0.115	0.000	
Radar Tower 2 Access	02+50	to	04+00	-	LSF 06	C	0.200	100	70	0.069	0.069
Radar Tower 3 Access	21+00	to	33+50	-	-	-	-	-	0.344	0.000	
T01	Turbine Pad Access			LSF 01	C	0.025	100	125	0.082	0.082	
T01	Crane Pad			LSF 01	C	0.025	100	125	0.149	0.149	
T01	Turbine Gravel Apron			LSF 01	C	0.025	100	125	0.097	0.097	
T02	Turbine Pad Access			LSF 02	C	0.022	100	70	0.056	0.056	
T02	Crane Pad			LSF 02	C	0.022	100	70	0.149	0.149	
T02	Turbine Gravel Ring			LSF 02	C	0.022	100	70	0.097	0.097	
T03	Turbine Pad Access			BF 01	C	0.031	100	210	0.044	0.044	
T03	Crane Pad			BF 01	C	0.031	100	210	0.149	0.149	
T03	Turbine Gravel Ring			BF 01	C	0.031	100	210	0.097	0.097	
T04	Turbine Pad Access			LSF 03	C	0.035	100	115	0.073	0.073	
T04	Crane Pad			LSF 03	C	0.035	100	115	0.149	0.149	
T04	Turbine Gravel Ring			LSF 03	C	0.035	100	115	0.097	0.097	
T05	Turbine Pad Access			BF 02	C	0.030	100	105	0.045	0.045	
T05	Crane Pad			BF 02	C	0.030	100	105	0.149	0.149	
T05	Turbine Gravel Ring			BF 02	C	0.030	100	105	0.097	0.097	
T06	Turbine Pad Access			BM 01	C	0.017	150	165	0.215	0.215	
T06	Crane Pad			BM 01	C	0.017	150	165	0.149	0.149	
T06	Turbine Gravel Ring			BM 01	C	0.017	150	165	0.097	0.097	
T07	Turbine Pad Access			BM 02	D	0.010	150	200	0.246	0.246	
T07	Crane Pad			BM 02	D	0.010	150	200	0.149	0.149	
T07	Turbine Gravel Ring			BM 02	D	0.010	150	200	0.097	0.097	
T08	Turbine Pad Access			BF 03	C	0.041	150	230	0.041	0.041	
T08	Crane Pad			BF 03	C	0.149	150	230	0.149	0.149	
T08	Turbine Gravel Ring			BF 03	C	0.097	150	230	0.097	0.097	
T09	Turbine Pad Access			LSF 04	D	0.061	150	110	0.061	0.013	
T09	Crane Pad			LSF 04	D	0.149	150	110	0.149	0.149	
T09	Turbine Gravel Ring			LSF 04	D	0.097	150	110	0.097	0.097	
T10	Turbine Pad Access			BF 04	D	0.061	180	208	0.061	0.061	
T10	Crane Pad			BF 04	D	0.149	180	208	0.149	0.149	
T10	Turbine Gravel Ring			BF 04	D	0.097	180	208	0.097	0.097	
T11	Turbine Pad Access			LSF 05	C	0.041	100	95	0.062	0.062	
T11	Crane Pad			LSF 05	C	0.149	100	95	0.149	0.149	
T11	Turbine Gravel Ring			LSF 05	C	0.097	100	95	0.097	0.097	

Western Maine Renewable Energy Project

Stormwater Treatment Calculations:

Watersheds draining to the Kennebec River via Chase Chase Stream, Basset Brook, Austin Stream and Mink brook Chapter 500, Stormwater Management, Section 4.B.(3).(c) describes a linear project. Required stormwater treatment of impervious area = 75%

BMP ID Legend

RSF = Road side Forested buffer
 RSM = Road side Meadow buffer
 BF = Forested buffer adjacent to road/small impervious area
 BM = Meadow buffer adjacent to road/small impervious area
 LSF = Forested level lip spreader buffer
 LSM = Meadow level lip spreader buffer
 DTF = Forested Ditch Turnout
 DTM = Meadow Ditch Turnout

Road ID	Station Location	BMP ID	Soil HSG	Buffer Slope (ft./ft.)	Min. Flow Path Length (ft.)	Buffer or Stone Berm Length (ft.)	Impervious Area (acres)	Impervious Area Treated (acres)
T12	Turbine Pad Access	LSF 06	C	0.041	100	130	0.043	0.043
T12	Crane Pad	LSF 07	C	0.149	100	130	0.149	0.149
T12	Turbine Gravel Ring	LSF 08	C	0.097	100	130	0.097	0.097
T13	Turbine Pad Access	LSM 01	D	0.041	150	203	0.044	0.044
T13	Crane Pad	LSM 01	D	0.149	150	203	0.149	0.149
T13	Turbine Gravel Ring	LSM 01	D	0.097	150	203	0.097	0.097
T14	Turbine Pad Access	BF 04	C	0.041	90	220	0.038	0.038
T14	Crane Pad	BF 04	C	0.149	90	220	0.149	0.149
T14	Turbine Gravel Ring	BF 04	C	0.097	90	220	0.097	0.097
Radar Tower 1	Radar Tower Pad	BF 05	C/D	0.110	150	150	0.230	0.230
Radar Tower 2	Radar Tower Pad	LSF 07	C	0.110	100	65	0.230	0.230
Radar Tower 3	Radar Tower Pad	BF 06	C	0.093	100	50	0.230	0.230
Substation	Substation Pad	LSF 08	C	0.110	100	50	1.313	1.313
Totals:							11.354	9.249

Impervious Area Eliminated:

Impervious Area	Total Area (acres)
Existing Roads	0.000
Total:	0.000

Revised Totals:	11.354	9.249
Percentage Impervious Area Treated:	81.46%	
Percentage Required:	75.00%	

Western Maine Renewable Energy Project

Stormwater Culvert Schedule:

Culvert ID	Road/Site ID	Station Location	Drainage Area (acres)	Q25 (cfs)	Culvert Diameter (in.)	Length (ft.)	Inv. In (ft.)	Inv. Out (ft.)	Slope (ft./ft.)
RC-01	Stream Road	12+16	1.86	1.47	18	63	1327.5	1327	0.008
RC-02	Stream Road	14+90	74.89	41.98	36	76	1312	1310	0.026
RC-03	Stream Road	59+25	35.49	20.67	24	67	1322	1320	0.030
RC-04	Stream Road	63+30	10.49	12.07	18	100	1334	1331	0.030
RC-05	Stream Road	36+30	31.75	16.58	21	60	1356	1355	0.017
RC-06	Stream Road	53+72	31.75	18.49	21	65	1356	1355	0.015
RC-07	Adjacent to Stream rd	92+00	5.74	00+14	21	58	1387	1386	0.017
PC-01	New Access Road-3	11+40	31.11	41.72	24	70	1283.5	1282	0.021
PC-02	New Access Road-3	-02+00	15.22	21.64	24	42	1298	1297.5	0.012
PC-03	New Access Road-3	-13+00	14.07	20	24	45	1309	1308	0.022
PC-04	New Access Road-3	-28+00	10.95	21.41	21	40	1322	1321.5	0.013
PC-5	New Access Road-5	0+50	5.76	11.23	21	135	1392	1390	0.015
PC-6	New Access Road-5	15+50	67.74	96.24	36	50	1384	1383	0.020
PC-7	New Access Road-4	00+40	28.54	28.28	24	91	1376	1375	0.011
PC-8	New Access Road-4	03+50	18.76	18.59	18	50	1374	1373.5	0.010
PC-9	New Access Road-4	08+90	7.90	8.42	18	50	1394	1393	0.020
PC-10	New Access Road-4	25+00	1.22	2.21	12	55	1493	1492	0.018
PC-11	New Access Road-4	32+50	1.97	3.47	12	65	1472	1471	0.015
PC-12A	New Access Road-4	38+50	3.17	5.12	12	100	1425	1423	0.020
PC-12B	New Access Road-4	39+20	3.17	5.12	12	255	1422.8	1417	0.023
PC-13	New Access Road-4	46+00	4.66	7.63	18	77	1363	1361	0.026
PC-14	New Access Road-4	47+75	13.20	13.94	18	64	1359	1356	0.047
PC-15	New Access Road-4	49+05	16.05	21.11	18	70	1359	1355	0.057
PC-16	New Access Road-4	53+00	0.85	2.53	12	70	1360	1359	0.014
PC-17	New Access Road-4	73+00	0.44	1.44	12	60	1481	1476	0.083
PC-18	New Access Road-4	91+70	28.70	29.8	21	117	1304	1297	0.060
PC-19	Radar Tower 2 Road	00+10	5.81	14.73	18	49	1450	1449	0.020
PC-20	Radar Tower 3 Road	10+45	1.84	4.66	12	50	1381	1380	0.020
PC-21	Radar Tower 3 Road	21+30	4.89	10.42	18	35	1394.75	1394.25	0.014
PC-22	Radar Tower 3 Road	24+30	4.68	7.78	18	40	1398	1397	0.025

GENERAL NOTES:

- SCALES NOTED ARE APPLICABLE TO FULL SIZE (24"X36") DRAWINGS ONLY. SCALE REDUCED DRAWINGS ACCORDINGLY.
- NORTH AS SHOWN HEREON IS REFERENCED TO GRID NORTH, NAD83 MAINE STATE PLANES, WEST ZONE, US FOOT.
- ELEVATIONS AS SHOWN HEREON ARE REFERENCED TO NAD 83.
- EXISTING TOPOGRAPHIC AND PLANIMETRIC SURVEY INFORMATION AS SHOWN HEREON IS THE RESULT OF AERIAL TOPOGRAPHIC MAPPING COMPLETED BY PHOTOGRAMMETRIC TECHNOLOGY, INC. DEVELOPED FROM AERIAL PHOTOGRAPHY COMPLETED BY PHOTOGRAMMETRIC TECHNOLOGY, INC.
- ENVIRONMENTAL RESOURCE MAPPING (WETLANDS, STREAMS, VERNAL POOLS, ETC.) AS SHOWN HEREON BY TETRA TECH.
- INVERTS SHOWN ON PROPOSED CULVERTS MAY BE ADJUSTED BASED ON FIELD CONDITIONS.

No.	Revision/Issue	Date

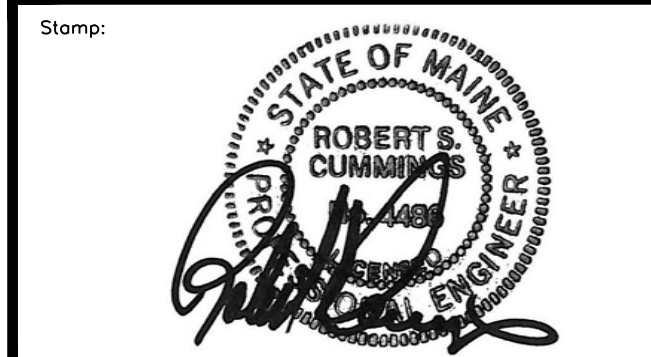

Drawing Title:
STORMWATER TREATMENT TABLES AND CULVERT SCHEDULE

||
||
||